



GMHD20-OBA

Install Guide

Revision: B



© Kleinn Automotive Accessories 2019, All rights reserved.

PO Box 91278 Tucson, AZ 85752

Phone: (520) 579-1531

Web: www.Kleinn.com

Table of Contents

1.	Application Chart.....	4
1.1.	List of compatible vehicles	4
1.2.	Incompatible Vehicle Features & Packages.....	4
1.3.	Aftermarket Product Compatibility	4
2.	Before You Start	5
3.	Installation Overview	5
3.1.	Kit Layout & Location.....	5
4.	List of Tools & Supplies.....	6
4.1.	Standard Tools	6
4.2.	Specialty Tools	6
4.3.	Consumables	6
5.	Parts List	7
5.1.	Primary Kit Components.....	7
5.2.	Fittings & Related Items	8
5.3.	Electrical Components & Related Items	9
5.4.	Mounting Brackets	9
5.5.	Hardware & Related Items	10
6.	Recommended Routing of Air Tubing & Wire.....	12
7.	Bench Assembly	13
7.1.	Rubber Trim – Cutting & Installation.....	13
7.2.	Air Tank – Fitting Installation.....	14
7.3.	Compressor – Fitting Installation	14
7.4.	INF-1 – Fitting Installation	14
8.	On-Vehicle Assembly.....	15
8.1.	Compressor Installation.....	15
8.2.	Tank Installation	20
8.3.	Air Tank Installation.....	23
8.4.	1302 Remote Air Quick Connect	25
8.5.	Final System Plumbing.....	25
9.	On-Vehicle Electrical Installation	26



Install Guide

GMHD20-OBA

- 9.1. Solenoid Connector – Reconfigure the Housing & Wiring 26
- 9.2. Attach Relay & Fuse to Vehicle..... 27
- 9.3. Install Horn Button 27
- 9.4. Route Wiring & Make Connections 28
- 10. Testing the Air System 29
 - 10.1. Air Compressor Test 29
 - 10.2. Air Horn Test..... 29
 - 10.3. Quick Connect Coupler Test 29
- 11. Maintenance 30
- 12. Warranty Information..... 31

1. Application Chart

This kit is a direct bolt-on aftermarket product. The vehicles listed in the below table are considered to be compatible with this aftermarket kit. Every effort has been made to verify fitment on these vehicles in their factory condition.

***WARNING:** Before unpacking your kit, review this manual in full & verify the correct space & mounting locations exist with your trim package.*

1.1. List of compatible vehicles

Year	Make	Model	Drivetrain	Engine	Cab	Bed	Trim
2020 +	Chevy	Silverado 2500HD	2WD 4WD	Vortec 6.6L Duramax 6.6L	Crew	Standard Long	Work Truck Custom LT LTZ High Country
		Silverado 3500HD					
2020 +	GMC	Sierra 2500HD				Standard Long	Pro SLE SLT AT4 Denali
		Sierra 3500HD					

***NOTE:** Drilling holes may be required for installing ground wires and switches based on the installer's preference.*

1.2. Incompatible Vehicle Features & Packages

This kit is **NOT COMPATIBLE** with the following vehicle features / packages:



- N/A

1.3. Aftermarket Product Compatibility

This kit has been designed to be compatible with the following products from leading manufacturers:

- AMP Research PowerSteps
 - **The tank must be positioned further back on the mounting bracket to avoid interference with the PowerSteps Motor. This adjustment blocks the mounting point for the nearby electrical connector. The connector may be secured by alternate means.**

This kit has not been designed to be compatible with the following products:

- Aftermarket running boards that utilize 4 mounting locations along the vehicle frame rails
- Carhartt Edition 
- Z71 Sports Edition 
- Midnight Edition 

These packages utilize running boards which contain one (1) mounting location that interferes with the placement of the air tank. **It may be possible to remove the interfering mounting bracket and install this aftermarket kit.**

2. Before You Start

Read this manual in its entirety before starting installation. Verify you have all the parts listed & that you clearly understand the installation procedure. Contact KLEINN Technical Support with any questions you may have.

Installation of this kit requires moderate mechanical aptitude.

Use the proper tools, supplementary lighting, and safety equipment when installing this kit.

3. Installation Overview

3.1. Kit Layout & Location

Item No.	Description	Mounting Location	Approx. Install Time
1	6450RC Air Compressor	Along the passenger side frame rail, between driver & passenger door	1 Hour
2	6353RT Air Tank	On the driver side frame rail, below the rear door	1 Hour
3	1302 Relocation Kit	TBD by Installer/Customer (Not Illustrated)	N/A

Note: Wiring time is not factored into the overall install time of this kit. See Section 6 for suggested wiring & plumbing routes.

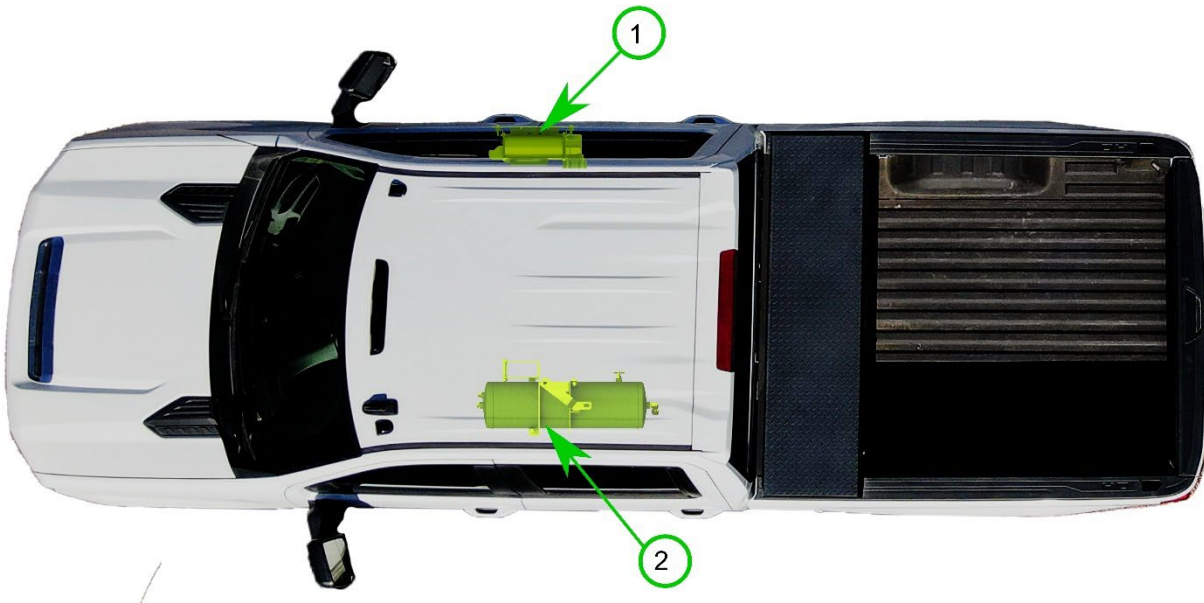

Figure 1- Kit Layout

4. List of Tools & Supplies

4.1. Standard Tools

- Mechanic's 1/4" & 3/8" Drive & Socket Set – Imperial & Metric
- Combination wrenches – Imperial & Metric
- Hex wrenches – Imperial & Metric
- Screwdriver Set – #1, #2
- Wire Cutters
- Wire Strippers
- Wire Crimpers
- Utility Knife or Equivalent
- Precision Screwdriver or Small Pry Tool

4.2. Specialty Tools

- 1/4" & 3/8" Universal Joints
- 1/4" & 3/8" Extensions
- Multimeter, Test Light, or Equivalent
- Heat Gun
- Trim Panel Removal Tools
- Drill Driver & Bits
- Impact Driver & Bits
- Wire Running Kit or Equivalent

4.3. Consumables



- Quality Electrical Tape
- Medium Strength Thread Locker
- Sandpaper, Wire Brushes or Equivalent
- Extra Zip Ties
- Touch-up Paint

5. Parts List



Unpackage & organize the kit contents and verify all parts listed below are included. Contact KLEINN Support if any questions arise.

5.1. Primary Kit Components



NOTE: Items in this section may come in their own packages which may include additional items, hardware, or documentation.

Item No.	Qty	Part No.	Description	Picture
1.	1	6450RC	150 PSI Waterproof Air Compressor Kit	
2.	1	6353RT	2.6 Gal. Air Tank, 9-Port	
3.	1	1302	Quick Disconnect Air Relocation Kit <i>NOTE: May be located within INF-1 Kit</i>	
4.	1	INF-1	Tire Inflator Kit	



5.2. Fittings & Related Items

Item No.	Qty	Part No.	Description	Picture
F1	1	51414F	¼" NPT Female to ¼" Compression	
F2	1	51414L	¼" NPT Male to ¼" Compression, Elbow	
F3	1	51414NPTL	¼" NPT Male to ¼" NPT Female, Elbow	
F4	1	52175	175 PSI Pop-Off Safety Valve	
F5	4	50040	¼" NPT Male, Hex Plug	
F6	1	52835	¼" NPT Male Drain Plug	
F7	1	2151	Pressure switch, 110 PSI On – 145 PSI Off	
F8	12 ft & 12 ft	25014	1/4" Air Tubing NOTE: May be located within INF-1 Kit	
F9	2	JUICE	NPT Thread Sealant	

5.3. Electrical Components & Related Items

Item No.	Qty	Part No.	Description	Picture
-	1	320	Momentary Switch, NO	
-	1	N/A	Wire Kit	
-	30 ft	N/A	3/8" Loom Pack	
-	10 ft	N/A	1/4" Loom Pack	

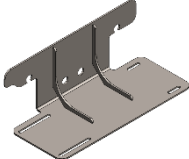
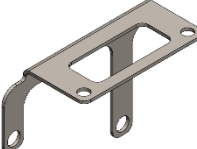
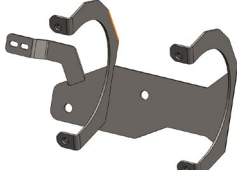
5.4. Mounting Brackets



Item No.	Qty	Part No.	Description	Picture
-	1	-	Compressor Bracket	
-	1	-	Module Relocation Bracket	
-	1	-	Tank Bracket	
-	2	-	Tank Strap	

5.5. Hardware & Related Items

Print out the hardware sheets at the end of this section at 100% Scale to facilitate hardware identification.

Item No.	Qty	Hardware Size	Description	Picture
H1	4	M10 x 1.5, 100mm Length	Hex Head Bolt	
H2	4	M10 x 1.5	Hex Nut	
H3	8	M10	Flat Washer	
H4	4		Split-Lock Washer	
H5	6	1/4"-20, 1" Length	Socket Head Cap Screw	
H6	8	1/4"	SAE Washer	
H7	6		Split-Lock Washer	
H8	2 ft	-	Narrow U-Strip, Rubber *	
H9	2	1/4"-20	Hex Nut	

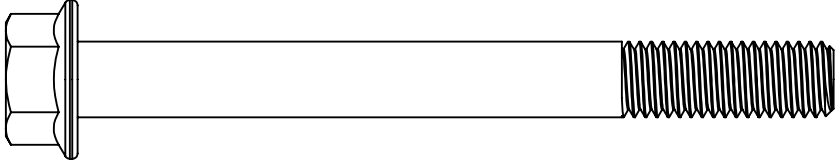
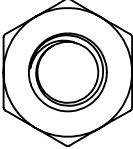
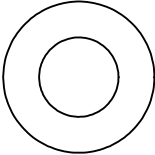
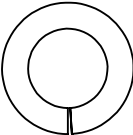
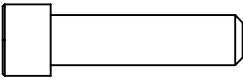
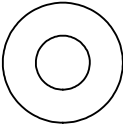
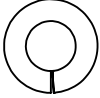
*Not Illustrated on the Scale Sheets

ITEM #	QTY	SCALE IMAGE
H1	4	
H2	4	
H3	8	
H4	4	
H5	6	
H6	8	
H7	6	
H8	2 FT	ITEM NOT ILLUSTRATED
H9	2	

NOTE:
SCALE IMAGES OF PRE-PACKAGED HARDWARE INCLUDED WITH THE COMPRESSOR ARE NOT ILLUSTRATED.

SCALE IMAGES OF UNIQUE & EASILY IDENTIFIABLE HARDWARE ARE NOT ILLUSTRATED.

THIS DOCUMENT IS DESIGNED TO BE VIEWED / PRINTED AT 100% OR "ACTUAL SIZE".

REVISION
1

REVISION DATE
5/4/2023



PRODUCT
GMHD20-OBA

DWG NO.
SCALE HARDWARE

SCALE: 1:1

SHEET SIZE A

SHEET 1 OF 1

6. Recommended Routing of Air Tubing & Wire

The below figures are a recommendation of the routing paths for both the air tubing & the wiring. Verify routing paths, wire lengths, & fuse/relay component locations before cutting the included wire. Reference Section 9 (On-Vehicle Electrical Installation) for a detailed electrical connection guide.

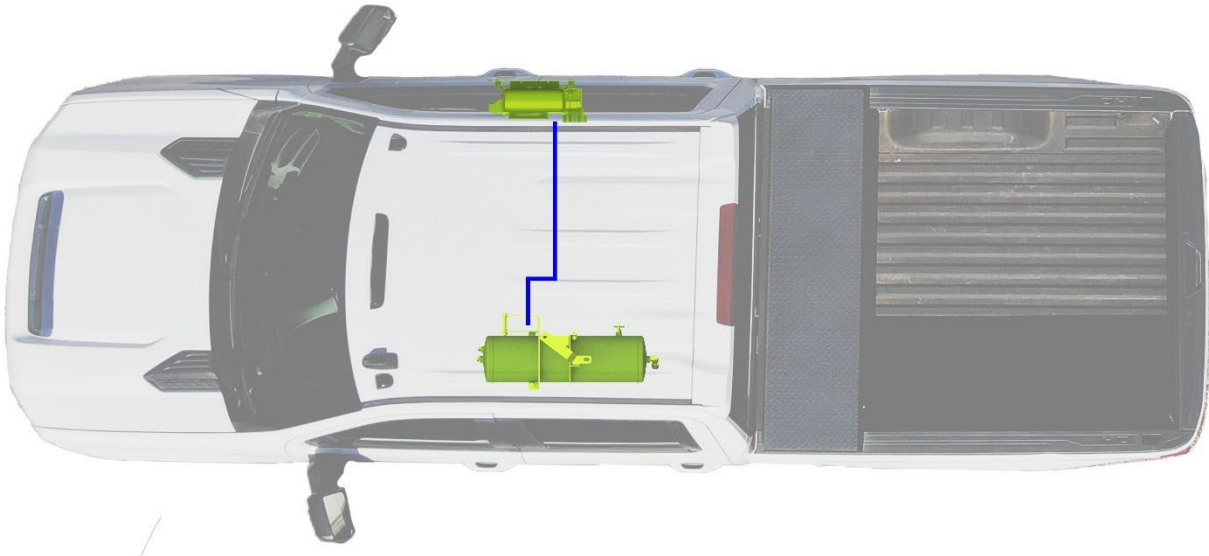

Figure 2- Recommended Air Tubing Routing

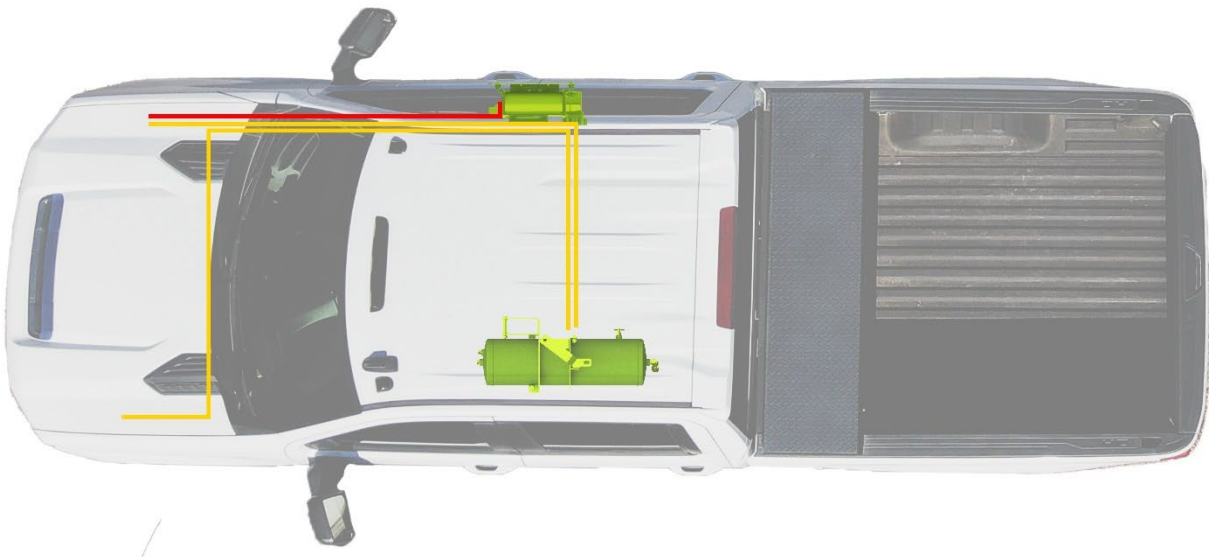

Figure 3- Recommended Electrical Routing (Grounding Points Not Shown)

7. Bench Assembly

7.1. Rubber Trim – Cutting & Installation

1. Cut hardware H8 & run the channel along the curved portions of the tank bracket as shown below.

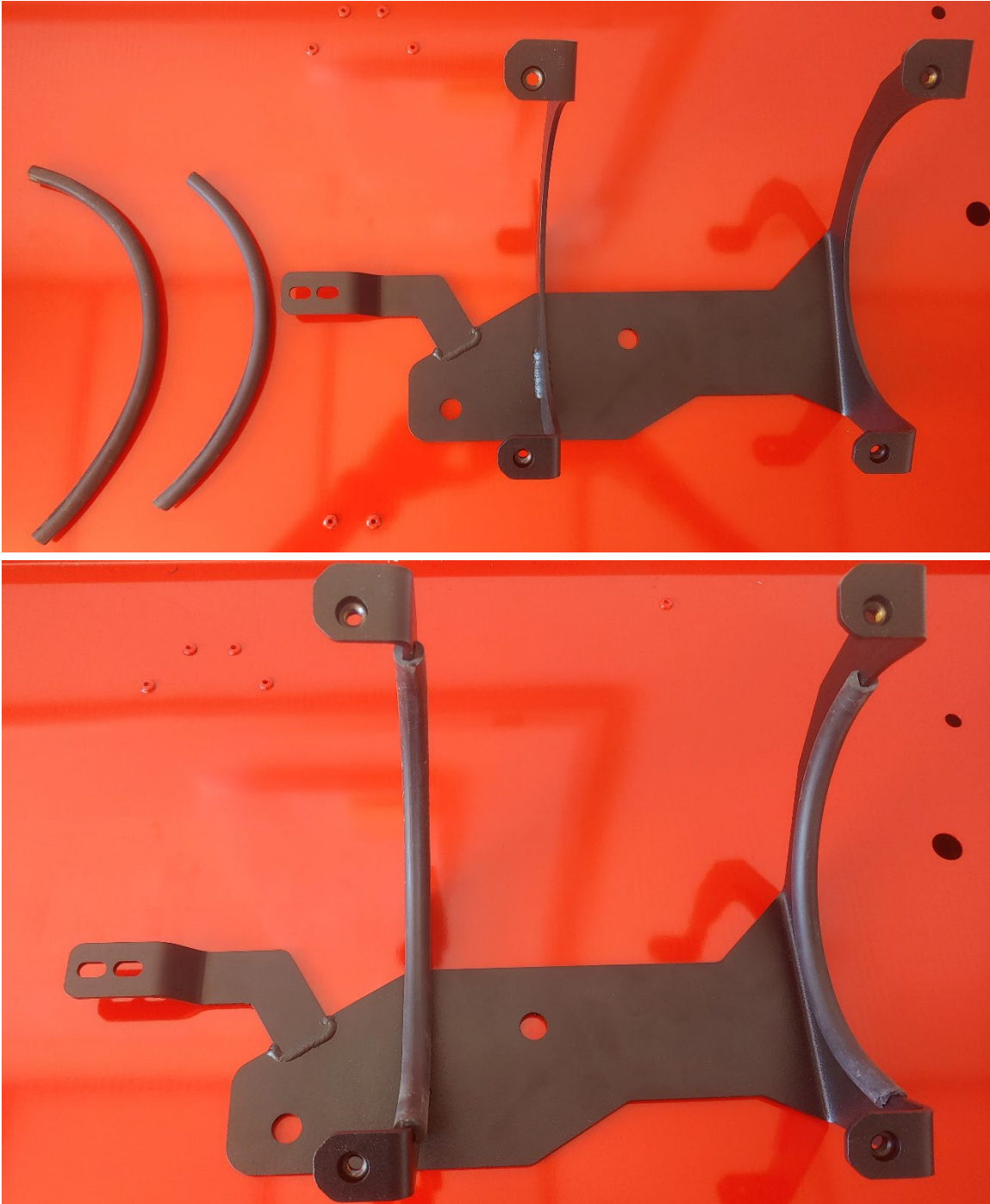

Figure 4- Rubber Trim Installation

7.2. Air Tank – Fitting Installation

Using KLEINN Juice, install the associated fittings onto the air tank as shown in the below figure.

Hand tighten the fittings, then further tighten 1/4 - 1/2 turn (or as needed) to match the orientation shown.

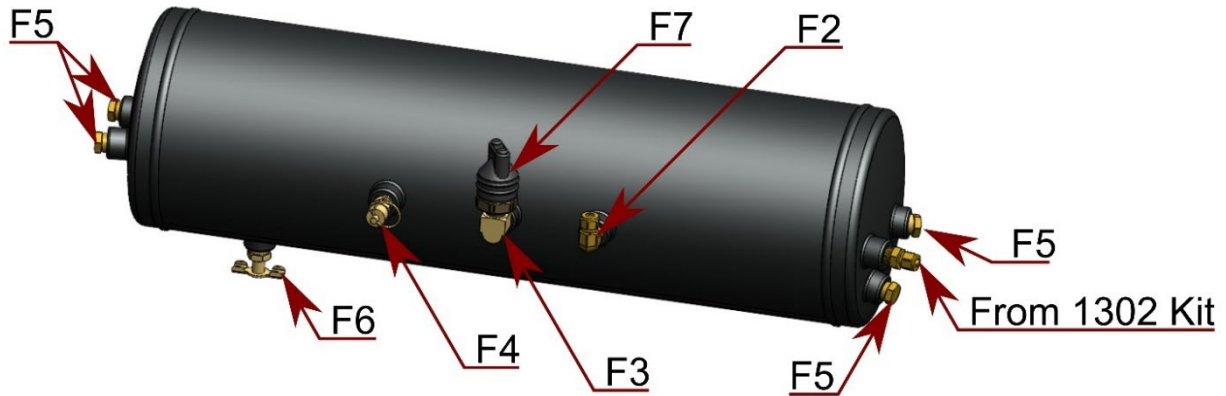

Figure 5- Air Tank Fittings, Orientation & Location

7.3. Compressor – Fitting Installation

- Using KLEINN Juice, apply 2-3 drops of the thread sealant onto the male threads of the compressor check valve.

NOTE: Ensure the check valve air outlet hole does not get covered by the JUICE.

- Install & hand tighten fitting F1 onto the threads and tighten 1/4 to 1/2 turn.



Figure 6- Compressor Fitting Installation

- Install the 1/4" air tubing onto the compression fitting.
- Install the inlet filter directly onto the air compressor, or, following the instructions included with the compressor, route & install the snorkel kit as desired.

7.4. INF-1 – Fitting Installation

- Use a few drops of the KLEINN Juice & install the INF-1 Fittings to the hose as desired.

8. On-Vehicle Assembly

8.1. Compressor Installation

The compressor is located on the passenger side of the vehicle, on the outside frame rail, slightly to the rear of the seam of the front & rear doors.

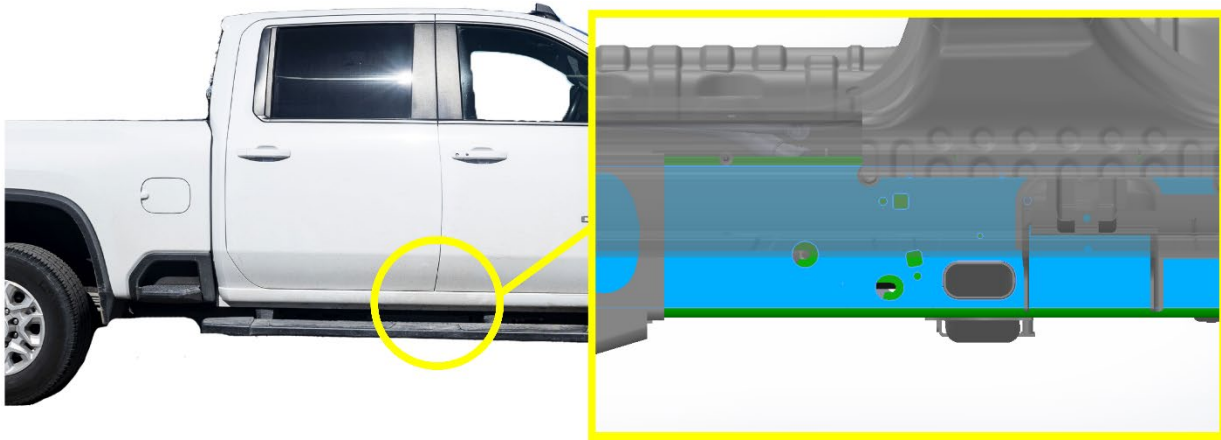

Figure 7- Compressor Install Location, Passenger Side

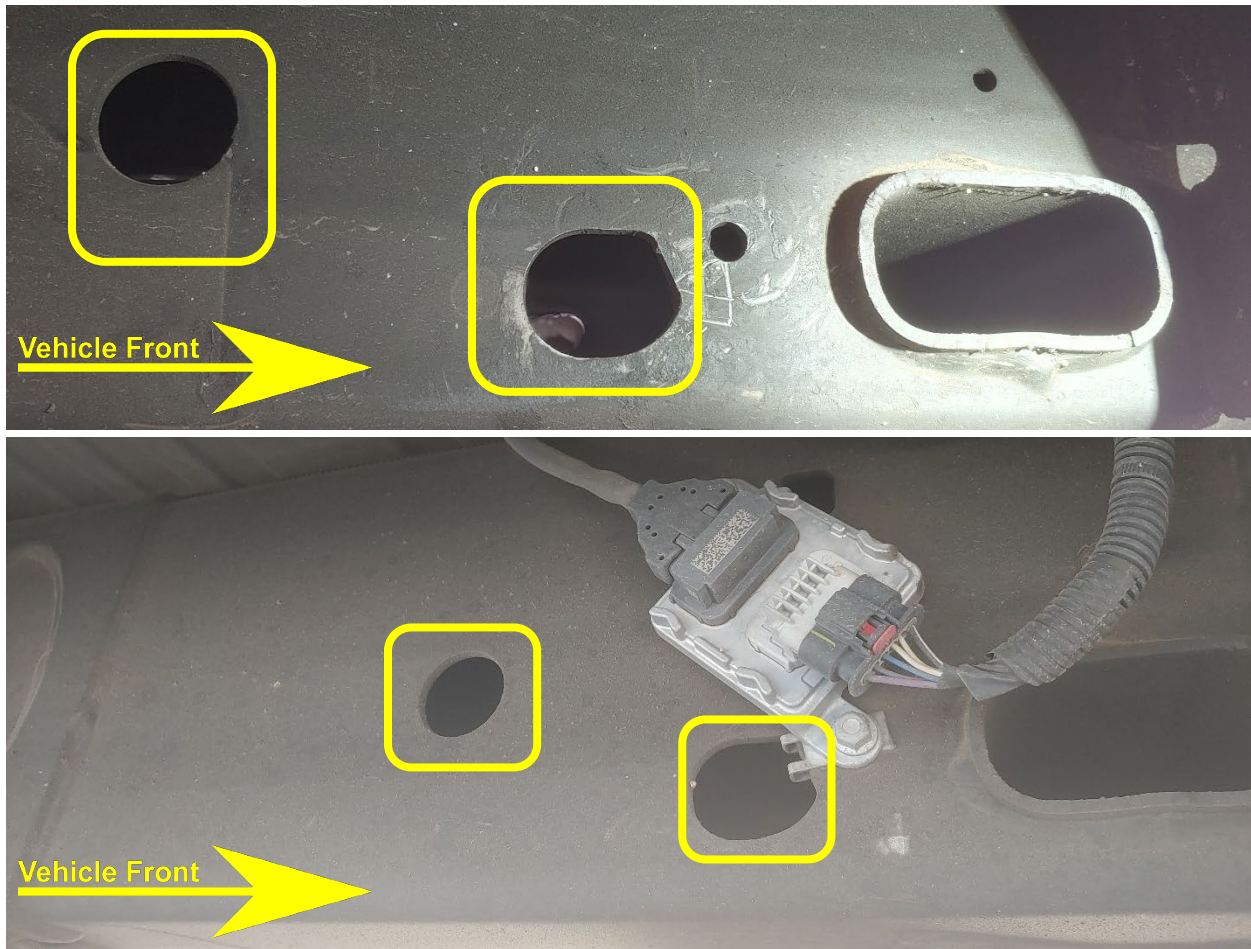

Figure 8- Compressor Bracket, Mounting Points (Above w/o Module, Below w/ Module)

NOTE: If your vehicle has the module that obstructs the compressor bracket location, you will need to use the included module relocation bracket when installing the compressor bracket.

1. If required, remove the computer module & the frame mounted U-Nuts from the frame rail. If the module is covered by a metal shield, perform the following steps.
2. Loosen all four (4) bolts by **TURNING THE TAIL TO THE RIGHT**. This will allow the bolt to loosen away from the inside of the frame.
3. Push up & pull the bracket towards you to remove.

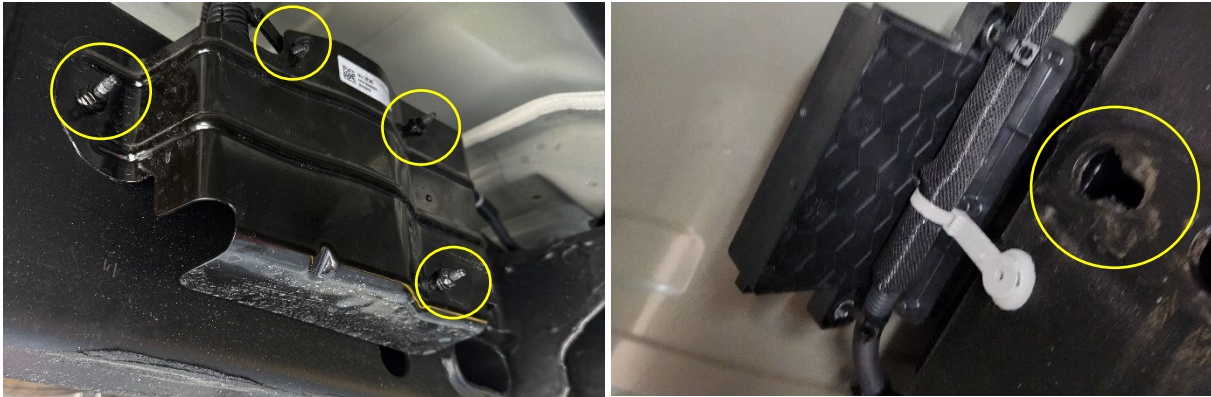

Figure 9- Module Shield Removal 1

4. Remove the bolts completely and detach the shield from the module.

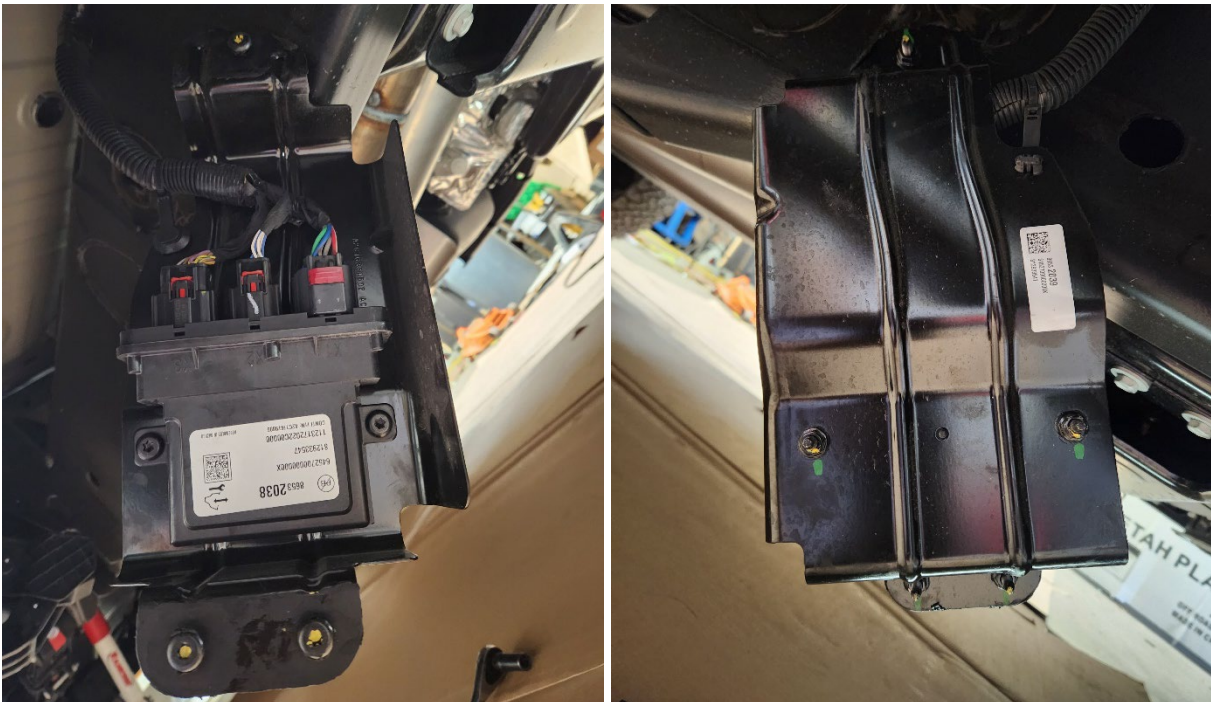

Figure 10- Module Shield Removal 2

NOTE: Proceed to the following installation steps based on Diesel or Gasoline Engines

For Gasoline Engines Only:

5. Place the compressor bracket onto the correct position on the frame rail and insert hardware H1 through the compressor bracket mounting holes & (if required), through the module relocation bracket as shown below.



Figure 11- Compressor Bracket Installation, Outside Frame Rail

6. Fully secure the bracket into position using hardware **in the order** H3, H4 & H2. Ensuring the threaded section of the bolts are in the upper-left slot of the frame rail as shown below.



Figure 12- Compressor Bracket Installation, Inside Frame Rail

7. If required, use hardware H5, H6, H7 & H9 to install the computer module onto the Module Relocation Bracket as shown below.

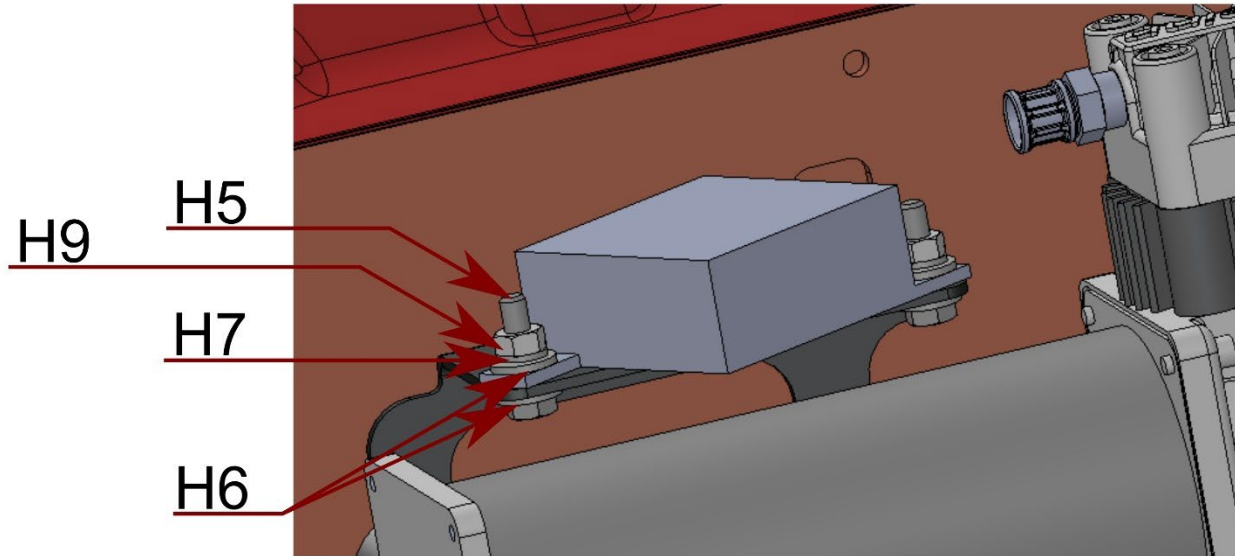

Figure 13- Computer Module, Hardware Stacking Order

8. Place the compressor onto the bracket. **The compressor head should be towards the vehicle front.**
9. Use the hardware included in the compressor box & fasten the compressor from the underside of the bracket as shown below.

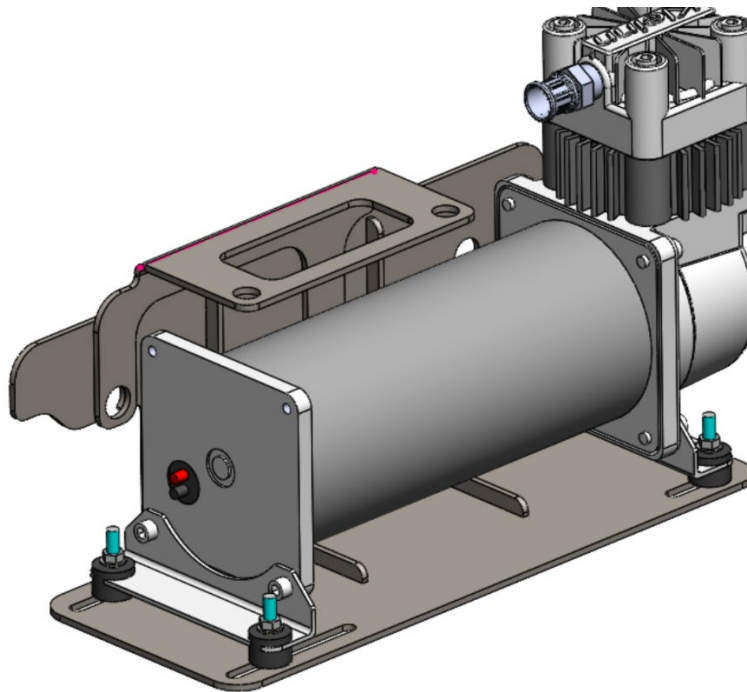

Figure 14- Compressor Mounted, Compressor & Hardware Orientation

For Diesel Engines Only:

5. Remove the crossmember's rightmost bolt that is recessed within the frame rail.
6. Place the compressor bracket onto the correct position on the frame rail and insert hardware H1 through the rightmost bracket mounting hole & (if required), through the module relocation bracket as shown below.



Figure 15- Compressor Bracket Installation 1, Diesel

7. Allow the bracket(s) to hang & remove the leftmost bolt that is recessed within the frame rail.
8. Slide the compressor bracket into position & insert hardware H1 through the leftmost bracket mounting hole & (if required), through the module relocation bracket as shown below.

NOTE: To achieve proper alignment, it may be necessary to slightly lift the wiring loom anchor post if it contacts the compressor bracket.



Figure 16- Compressor Bracket Installation 2, Diesel

9. Fully tighten hardware H1 & (if required), attach the module to the relocation bracket using hardware H5, H6, H7 & H9 as shown in the above Figure 11.

8.2. Tank Installation

The air tank mounts to the outside frame rail (driver side) that is in line with the rear door.

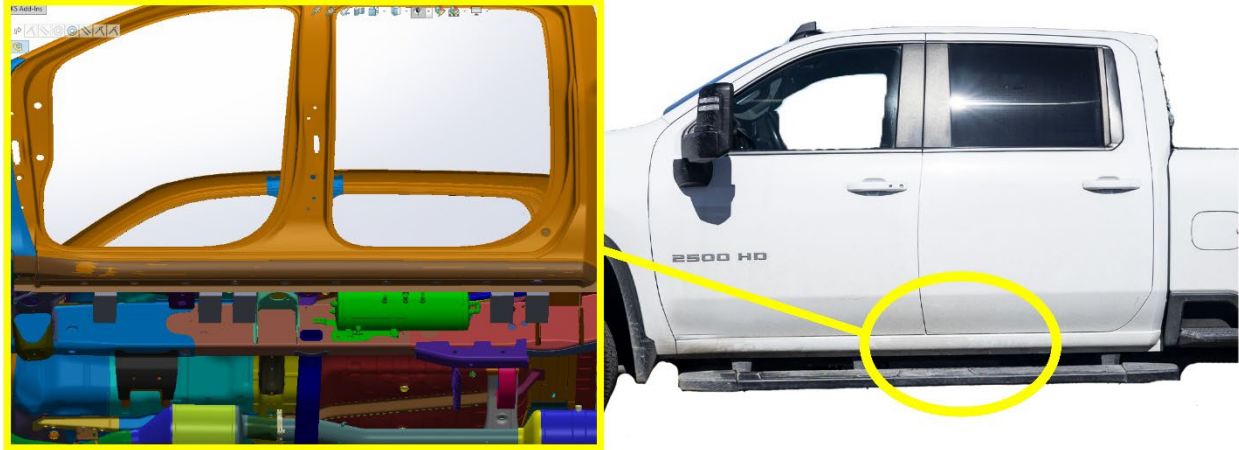

Figure 17- Tank Install Location, Driver Side



Figure 18- Tank Frontmost Bracket, Mounting Point

1. Pry off the electrical connector from the frame rail and move aside to gain access to the tank bracket mounting location shown in the above figure.

For Gasoline Engines Only:

2. Use hardware H1 to place the tank bracket onto the frame rail. Ensure the threaded portion of the bolts are in the upper slots of the frame as shown below.



Figure 19- Tank Bracket Installation, Inside Frame Rail

3. Fully secure the bracket into position using hardware H3, H4 & H2,
4. Route the connector wiring and secure the connector to one of the slots on the tab of the tank bracket as shown below.



Figure 20- Tank Bracket Installation, Connector Placement

For Diesel Engines Only:

2. Remove the crossmember's leftmost bolt that is recessed within the frame rail.
3. Place the tank bracket onto the correct position on the frame rail & insert hardware H1 through the leftmost bracket mounting hole as shown below.



Figure 21- Tank Bracket Installation 1, Diesel

4. Fasten the bolt enough to allow the bracket to suspend but still allow for bracket articulation.
5. Remove the right side bolt that is recessed within the frame rail, swivel the bracket into place and fasten the bracket using hardware H1 & attach the connector to one of the slots on the tank bracket, as shown in figure 18 above.

8.3. Air Tank Installation

The Air Tank is to be set in place with the 2 plugged ports oriented towards the front of the vehicle & the drain valve directed to the floor.

NOTE: For vehicles equipped with Amp Research PowerSteps, place tank in accordance with SB-001 on the following page.

1. Place the tank onto the bracket aligned as shown below & hold it in place.
2. Use hardware H5, H6 & H7 to fully secure the tank straps to the bracket as shown below.

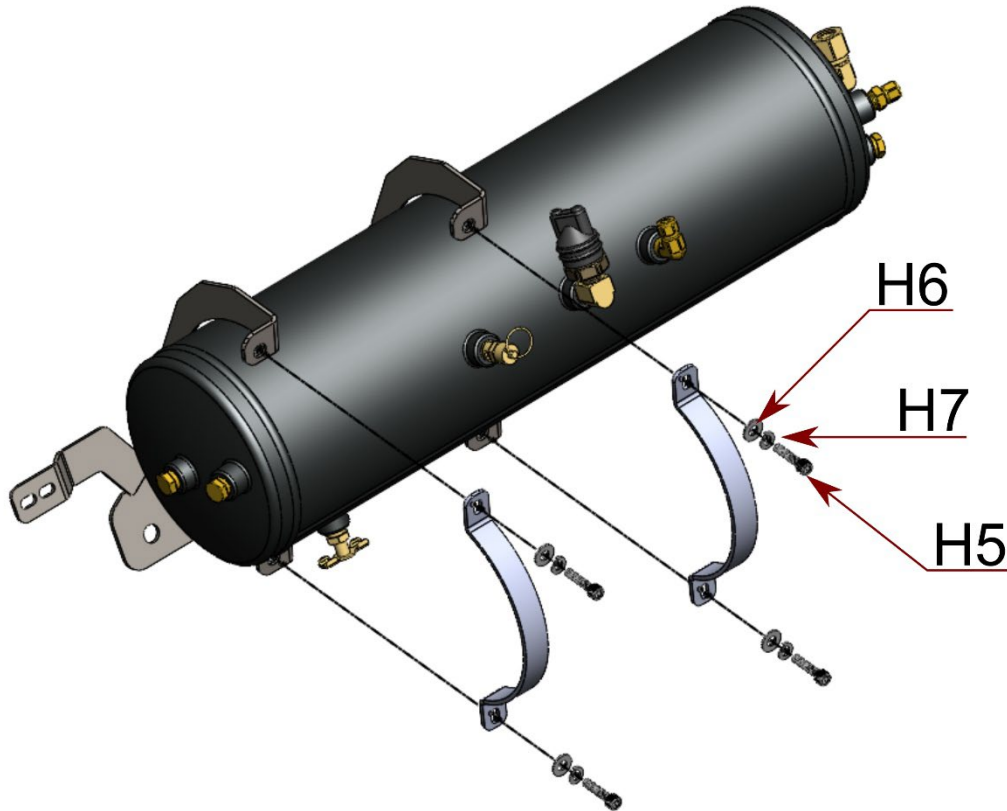
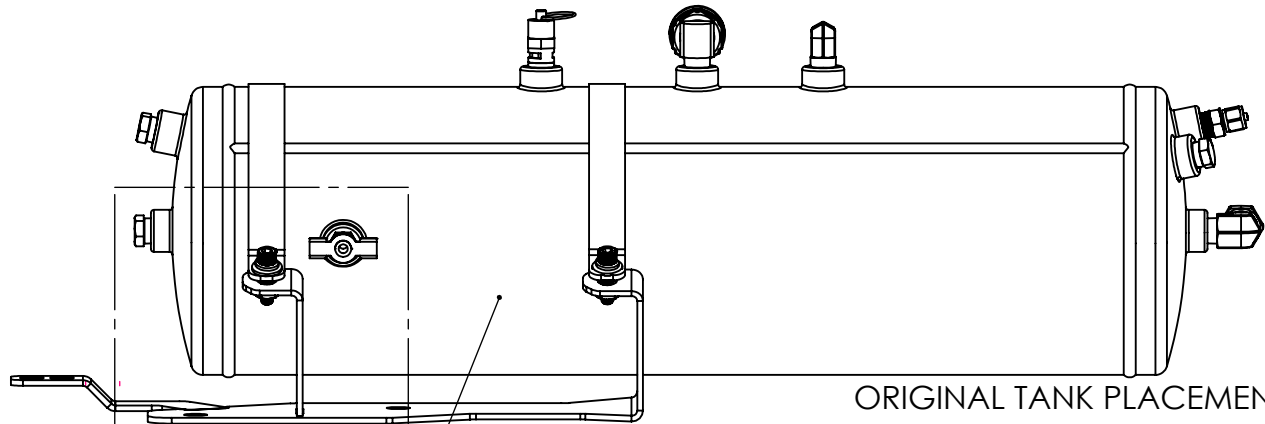

Figure 22- Tank & Tank Strap Installation

MODIFIED TANK PLACEMENT TO ACCOMODATE AMP RESEARCH POWERSTEPS



ORIGINAL TANK PLACEMENT

THE TANK MUST BE SHIFTED TO ACCOMODATE THE POWERSTEPS MOTOR. THIS CHANGE WILL CLAIM THE SPACE FOR THE NEARBY ELECTRICAL CONNECTOR WHICH MAY BE SECURED TO THE VEHICLE ELSEWHERE

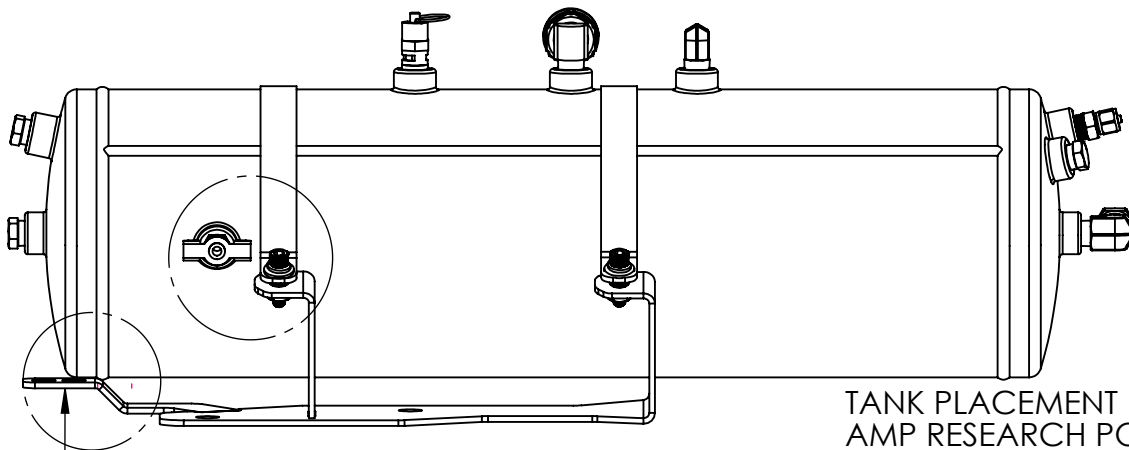

TANK PLACEMENT FOR AMP RESEARCH POWERSTEPS

NO LONGER USEABLE FOR THE NEARBY ELECTRICAL CONNECTOR. FIND AN ALTERNATE LOCATION TO SECURE THE CONNECTOR.

REVISION	REVISION DATE
1	6/7/2023



PRODUCT	DWG NO.
GMHD20	SB-001
SCALE: 1:4	SHEET SIZE A
SHEET 1 OF 1	

8.4. 1302 Remote Air Quick Connect

1. Assemble & Install the 1302 quick connect kit in any desired location. Ensure there is a path to route the air tubing from the tank to the 1302 kit.
2. Use KLEINN Juice for the NPT threads as needed.

NOTE: Use the exploded view below as a guide when installing the 1302 kit.

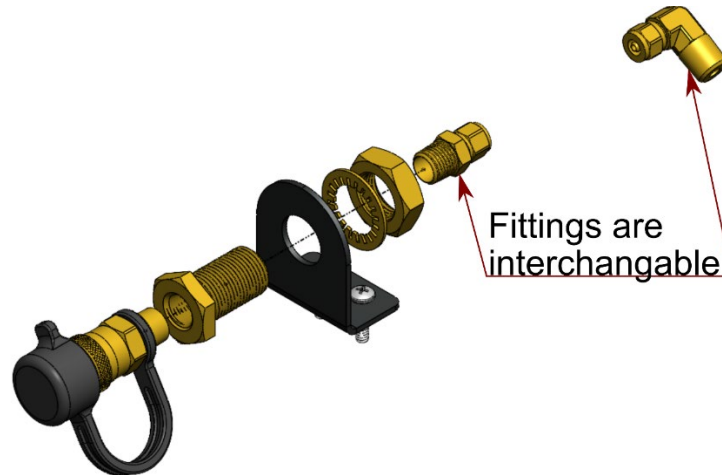

Figure 23- 1302 Quick Connect Kit, Assembly View

8.5. Final System Plumbing

1. Using the air tubing included with the air horns, route & connect the tubing between the air tank & the horn solenoid.
2. Route & connect the tubing from the compressor to the air tank.
3. Using the 1/4" air tubing, route and connect the tank to the 1302 Quick Connect.

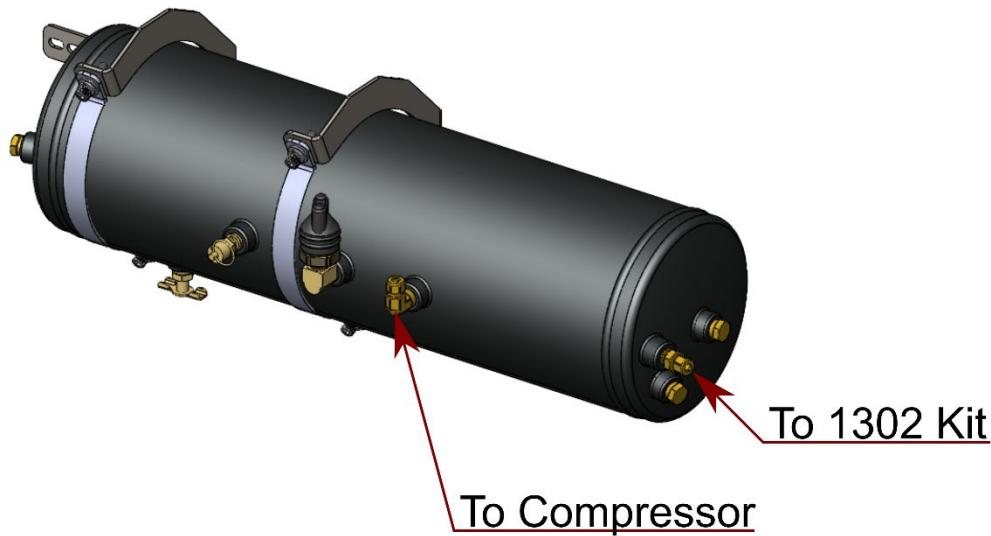

Figure 24- Final Plumbing of Air System

4. Install the air horn trumpets onto the respective horn drivers.

9. On-Vehicle Electrical Installation

It is recommended to disconnect the vehicle battery prior to performing any electrical work.

NOTE: Review this section in its entirety before performing the following steps.

9.1. Solenoid Connector – Reconfigure the Housing & Wiring

To allow for proper fitment, the solenoid connector housing needs to be reconfigured 180°. **It must be disassembled and reassembled at the proper orientation.**



Original Configuration

Final Configuration

Figure 25- Solenoid Connector, Required Orientation

1. If not already detached, remove the electrical connector from the solenoid.
2. Remove the rubber boot to expose the separation slot.
3. Use a small pry tool to separate the connector from the housing.



Figure 26- Connector / Housing Separation

4. Flip the housing over 180°.
5. Hookup the Black & Violet wires to the highlighted terminals. Either wire can connect to either terminal.

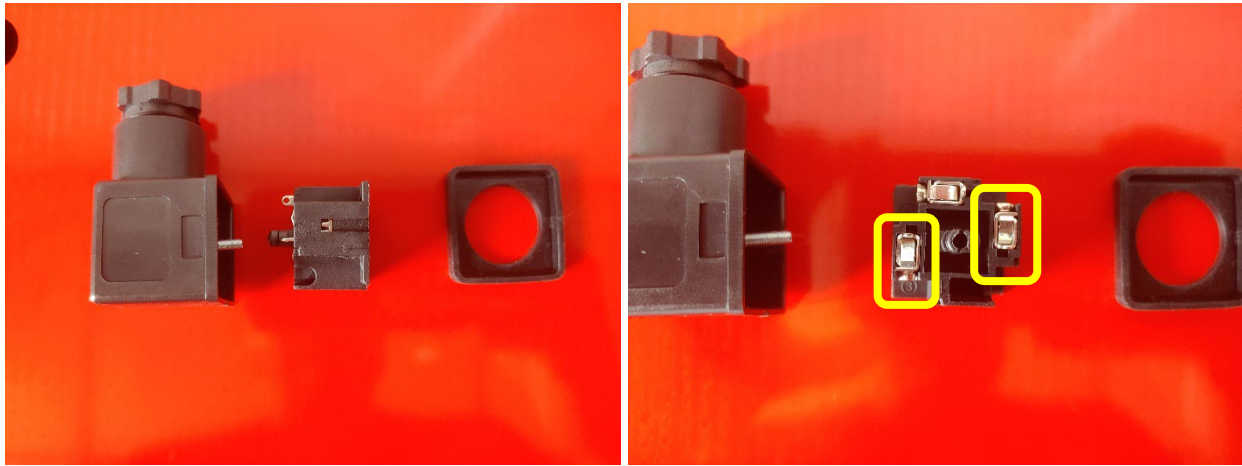

Figure 27- Connector Assembly & Wiring Hookups

6. Reassemble the connector.
7. Install the connector back onto the solenoid.

NOTE: It is recommended to use the included loom for all wiring applications.

9.2. Attach Relay & Fuse to Vehicle

Locate a suitable location under the hood and install the fuse housing & relay.

- For the Fuse: Select an area close to the POS (+) battery terminal.
- The fuse housing can be attached to the vehicle body panel using the supplied screws.
- The relay can be attached to the vehicle body using the supplied self-tapping screws.

9.3. Install Horn Button

Locate a desirable & accessible location to install the horn button. There should be a minimum of 1" clearance behind the chosen location to allow for the switch to be mounted and wired easily.

Factory upfitter switches may be used at the installers/customers discretion. Consult the owner's manual or OEM documentation if using this option.

9.4. Route Wiring & Make Connections

Route wiring as desired and make the appropriate connections per the below figure. Use the included wiring loom and crimp connectors as desired.

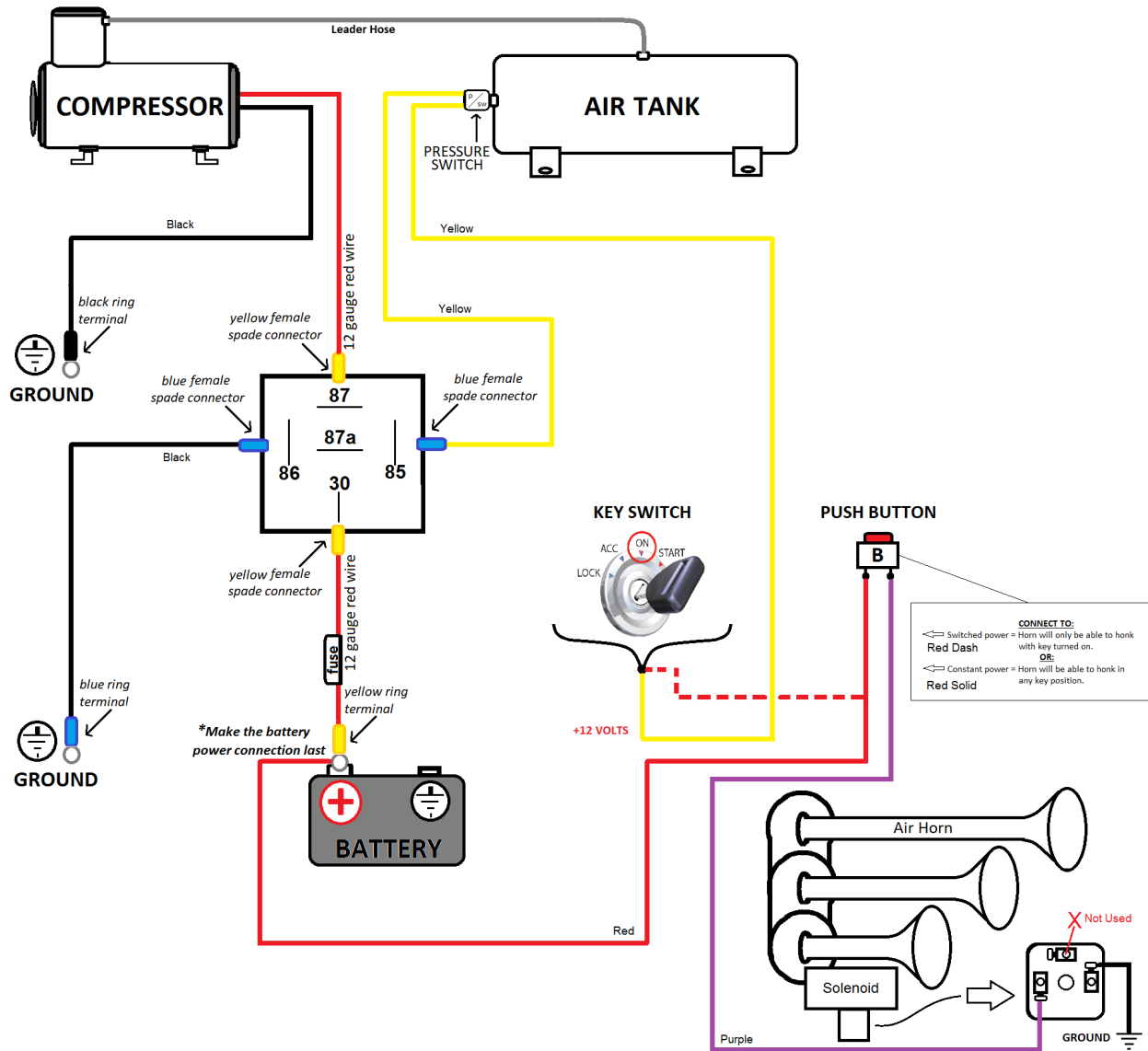

Figure 28- System Wiring Diagram

10. Testing the Air System

It is recommended to check your wiring for shorts & continuity prior to reconnecting the battery.

It is recommended to check the drain valve on the tank and ensure it is fully closed.

10.1. Air Compressor Test

1. Start the vehicle & allow the air compressor to run and fill up the tank.

NOTE: The compressor should turn off after tank reaches \approx 150 PSI. This should take between 2-5 minutes. If the compressor runs excessively, a leak may be present in the system.

2. Allow the tank to drain via, the horns (if installed), the Inflator kit, or the tanks drain valve.
3. Wait for the compressor to start up again to replenish the air supply.
4. Wait for the compressor to turn off when tank is fully pressurized.

10.2. Air Horn Test

Ensure all persons nearby have adequate hearing protection & provide courtesy warning to neighbors before testing the horn system.

!!WARNING!! NEVER operate the air horns with a person's ears near the trumpets or in an enclosed space without SUBSTANTIAL HEARING PROTECTION for all persons closer than 50 feet from the vehicle.!!

1. Activate the air horns by pressing the horn button briefly. Horns should sound as expected and be loud.

The horn sound & loudness will diminish as the air tank loses pressure. Repeat, if desired, until the compressor turns on and begins refilling the air tank.

10.3. Quick Connect Coupler Test

The quick connect coupler can be used to run the included INF-1 tire inflator kit or certain air tools.

1. If needed, allow the air compressor to refill the air tank.
2. Attach the INF-1 inflator kit and inflate tires.
3. Optionally, an air blow gun or other air tool can be used to test the quick connect coupling.

11. Maintenance

!!WARNING!! Operating the air compressor above its maximum pressure rating may damage the internal components and/or cause unsafe system conditions. It is recommended not to exceed 150 PSI pressure in the system.!!

This air compressor is equipped with automatic thermal overload protection. If thermal overload is triggered, the safety circuit will reset after 30 minutes.

This air compressor is oil-less, never lubricate or add liquids to this compressor.

Monthly or every 10 Hours of Compressor Use:

- Drain the moisture from the air tank via the tank's drain valve.

Yearly or 12,000 Miles

- Replace the compressor's air filter element. – Replacement frequency depends on operating & environmental conditions.
- Remove road grime or mud from components & brackets.
- Inspect all mounting fasteners to ensure they remain secure. Tighten as needed.
- Inspect electrical connections & loom for damage. Repair/Replace as needed.

12. Warranty Information

Thank you for purchasing this Air System. If you experience any unexpected problems during installation, or part failure at any time, please contact KLEINN Support.

KLEINN MANUFACTURER LIMITED DEFECT WARRANTY:

Kleinn Automotive Accessories warrants this product to the end-user, when properly installed and under normal conditions of use, to be free from defects in workmanship and materials for a period of one year from the provided date of purchase to the original purchaser of the product. This warranty does not cover abuse, operation in a manner inconsistent with the product's design, or damage resulting from exposure to the elements. If the defect is considered "under warranty", Kleinn will, at its option, repair or replace the product free of charge to the original purchaser. Kleinn is not liable for any installation charges, loss or damage of any kind incurred in the replacement or repair of any warranted product.

© Kleinn Automotive Accessories 2019, All rights reserved.

PO Box 91278 Tucson, AZ 85752

Phone: [\(520\) 579-1531](tel:5205791531)

Web: www.Kleinn.com



Install Guide

GMHD20-OBA

Record of Revisions

Revision	Description	Date	Approval
A	Initial Revision	06/08/2023	AG
B	Updated logo Updated color scheme Added steps 2-4 on pg 16 -removal of electronic module shield Added figures 9 & 10	4/12/2024	AG