



RAM19-734

Install Guide

Revision: BETA 0.1



© Kleinn Automotive Accessories 2019, All rights reserved.

PO Box 91278 Tucson, AZ 85752

Phone: (520) 579-1531

Web: www.Kleinn.com

Table of Contents

1.	Application Chart.....	4
1.1.	List of compatible vehicles	4
1.2.	Incompatible Vehicle Features & Trim Packages	4
1.3.	Aftermarket Product Compatibility	4
2.	Before You Start	5
3.	Installation Overview	5
3.1.	Kit Layout & Location.....	5
4.	List of Tools & Supplies.....	6
4.1.	Required Tools.....	6
4.2.	Specialty Tools	6
4.3.	Consumables	6
5.	Parts List	7
5.1.	Primary Kit Components.....	7
5.2.	Fittings & Related Items	7
5.3.	Electrical Components & Related Items.....	8
5.4.	Mounting Brackets	8
5.5.	Hardware & Related Items	9
6.	Recommended Routing of Air Tubing & Wire.....	10
7.	Bench Assembly	11
7.1.	Combine Upper & Lower Dual Horn Bracket.....	11
7.2.	Horn / Ore Bracket & Large Horn Preparation	11
7.3.	Install Tank Fittings onto Air Tank	12
7.4.	Medium Horn Fitting Replacement & Solenoid Installation	13
7.5.	Assemble 1302 Kit & INF-1 Kit.....	14
8.	On-Vehicle Assembly.....	15
8.1.	Install Compressor Support Bracket	15
8.2.	Install Tank / Compressor & Bracket	17
8.3.	Large Horn & Horn / Ore Bracket Installation	20
8.4.	Dual Horn Bracket & Horns Installation	22
8.5.	Plumbing.....	25
9.	On-Vehicle Electrical Installation	26
9.1.	Reconfigure the Solenoid Connector Housing	26



Install Guide

RAM19-734

- 9.2. Attach Relay & Fuse to Vehicle..... 27
- 9.3. Install Horn Button 27
- 9.4. Route Wiring & Make Connections 27
- 9.5. Wrapping Up..... 28
- 10. Testing the Air System 29
 - 10.1. Air Compressor Test 29
 - 10.2. Air Horn Test..... 29
 - 10.3. Quick Connect Coupler Test 29
- 11. Maintenance..... 30
- 12. Warranty Information..... 31

1. Application Chart

This kit is a direct bolt-on aftermarket product. The vehicles listed in the below table are considered to be compatible with this aftermarket kit. Every effort has been made to verify fitment on these vehicles in their factory condition.

NOTE: Before unpacking your kit, review this manual in full & verify the correct space & mounting locations exist with your trim package.

1.1. List of compatible vehicles

Year	Make	Model	Drivetrain	Engine	Cab	Bed	Trim
2019-2024	RAM	1500	8-Speed Auto 850RE	3.6L V6 24V VVT eTorque Engine with Start/Stop	Crew Cab 5'7"	N/A	Tradesman Tradesman HFE Big Horn Laramie Rebel Limited Longhorn Limited
				5.7L V8 HEMI MDS VVT			
				5.7L V8 HEMI MDS VVT eTorque Engine with Start/Stop			
			8-Speed Auto 8HP75	3.0L V6 Turbo Diesel Engine Gen4	Crew Cab 6'4"		

NOTE: Drilling holes may be required for installing ground wires and switches based on installers preference.

1.2. Incompatible Vehicle Features & Trim Packages

This kit is **NOT COMPATIBLE** with the following vehicle features / trim packages:

- Any Quad Cab cabin size
- Factory running boards that utilize 3 or more mounting locations on the body panels along the vehicle frame rails. 

The running boards contain one (1) mounting location (center) that interferes with the placement of horn brackets. It may be possible to remove the interfering mounting bracket and install this aftermarket kit.

- Factory Power Steps

1.3. Aftermarket Product Compatibility

This kit has been designed to be compatible with the following products from leading manufacturers:

- N/A

This kit has not been designed to be compatible with the following products:

- N/A

2. Before You Start

Read this manual in its entirety before starting installation. Verify you have all the parts listed & that you clearly understand the installation procedure. Contact KLEINN Technical Support with any questions you may have.

Installation of this kit requires moderate mechanical aptitude.

Use the proper tools, supplementary lighting, and safety equipment when installing this kit.

3. Installation Overview

3.1. Kit Layout & Location

Item No.	Description	Mounting Location	Approx. Install Time
1	6450RC Air Compressor	Attached to & In-front of crossmember	1 Hour
2	6355RT Air Tank	Attached to & In-front of crossmember	1 Hour
3	730 Air Horns	Along the driver side frame rail, mounted to the body studs	2 Hours
4	1302 Relocation Kit	To be determined by Installer/Customer	1 Hour

Note: Wiring time is not factored into the overall install of this kit.

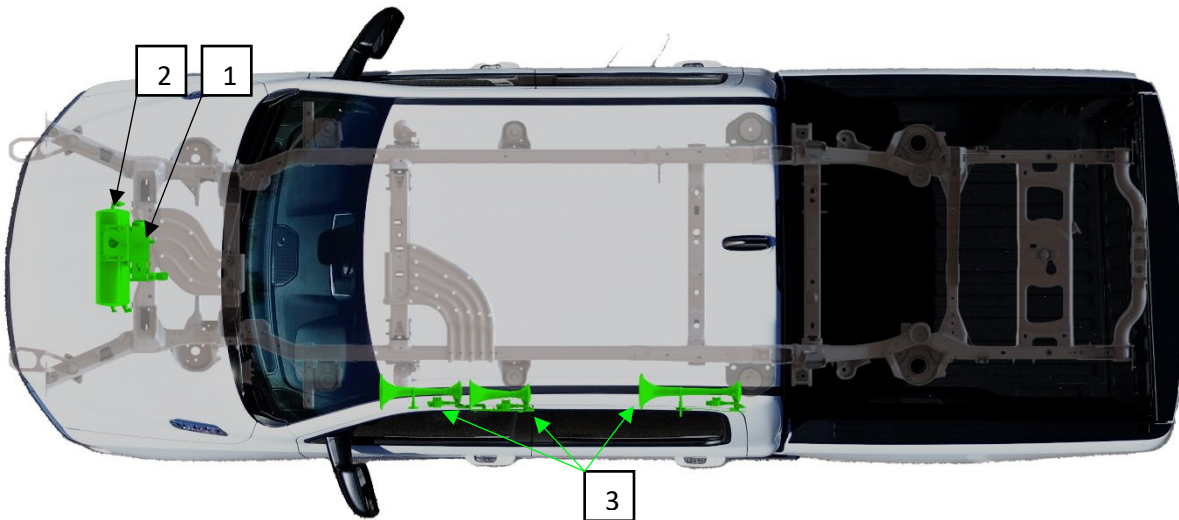

Figure 1- Kit Layout

4. List of Tools & Supplies

4.1. Required Tools

- Mechanic's 1/4" & 3/8" Drive & Socket Set – Imperial & Metric
- Combination wrenches – Imperial & Metric
- Hex wrenches – Imperial & Metric
- Screwdriver Set – #1, #2
- Wire Cutters
- Wire Strippers
- Wire Crimpers
- Utility Knife or Equivalent
- Magnetic Retrieval Tools (Flexible)
- Dead Blow Hammer or Equivalent

4.2. Specialty Tools

- 1/4" & 3/8" Universal Joints
- 1/4" & 3/8" Extensions
- Multimeter, Test Light, or Equivalent
- Heat Gun
- Trim Panel Removal Tools
- Drill Driver & Bits
- Impact Driver & Bits

4.3. Consumables





- Quality Electrical Tape
- Medium Strength Thread Locker
- Sandpaper, Wire Brushes or Equivalent
- Extra Zip Ties
- Touch-up Paint
- PTFE Thread Sealing Tape

5. Parts List





Unpackage & organize the kit contents and verify all parts listed below are included. Contact KLEINN Support if any questions arise.





5.1. Primary Kit Components

NOTE: Items in this section may come in their own packages which may include additional items, hardware, or documentation.



Item No.	Qty	Part No.	Description	Picture
1.	1	6450RC	150 PSI Waterproof Air Compressor Kit	
2.	1	6355RT	2.6 Gal. Air Tank, 9-Port	
3.	1	730	730 Series Air Horn Kit	
4.	1	1302	Quick Disconnect Air Relocation Kit	
5.	1	INF-1	Tire Inflator Kit	

5.2. Fittings & Related Items





Item No.	Qty	Part No.	Description	Picture
F1.	2	51414NPTL	¼" NPT Male to ¼" NPT Female, Elbow	
F2.	2	51414L	¼" NPT to Compression, Elbow	
F3.	1	51212L	½" NPT Male to ½" Compression, Elbow	
F4.	1	52175	175 PSI Pop-Off Safety Valve	
F5.	1	2151	Pressure Switch, 110 PSI On – 145 PSI Off	

F6.	1	52835	¼" NPT Male Drain Plug	
F7.	2	JUICE	KLEINN Liquid Thread Sealant	
F8.	12'	25014-1	¼" O.D. Air Tubing	
F9.	12'	25012-1	½" O.D. Air Tubing	

5.3. Electrical Components & Related Items

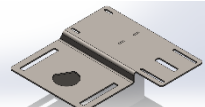
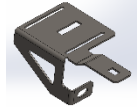
Item No.	Qty	Part No.	Description	Picture
	1	320	Momentary Switch, NO	
	1	6858	Wire kit w/ FT4-10 Fuse Tap	
	10'	SLT14	¼" Loom Pack	
	10'	SLT38	3/8" Loom Pack	
	10'	SLT12	½" Loom Pack	





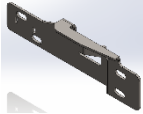





5.4. Mounting Brackets

Item No.	Qty	Part No.	Description	Picture
	1	RAM19-10	Tank / Compressor Bracket	
	1	RAM19-11	Compressor Support Bracket	
	1	RAM19-12	Cutaway Washer	
	1	RAM19-30	Horn / Ore Bracket	
	1	RAM19-31	Dual Horn Bracket, Lower	

	1	RAM19-32	Dual Horn Bracket, Upper	
--	---	----------	--------------------------	---

5.5. Hardware & Related Items

Print out the hardware sheets at the end of this section at 100% Scale to facilitate hardware identification.

Item No.	Qty	Hardware Size	Description	Picture
H1.	6	7/16-14	Hex Bolt, 1" Long	
H2.	2		Square Neck Carriage Bolt, 1" Long	
H3.	7		Hex Nut	
H4.	1		Nylon Lock Nut	
H5.	7	7/16	SAE Washer	
H6.	7		Split-Lock Washer	
H7.	4	M8 x 1.25	Hex Bolt, 20mm Long	
H8.	10		Hex Nut	
H9.	10	M8	Washer	
H10.	10		Split-Lock Washer	
H11.	4	0.25" Height	GMTRK4-103, Spacer	

*Not Illustrated on the Scale Sheets

6. Recommended Routing of Air Tubing & Wire

The below figures are a recommendation of the routing paths for both the air tubing & the wiring. Verify routing paths, wire lengths, & fuse/relay component locations before cutting the included wire. Reference Section 9 (On-Vehicle Electrical Installation) for a detailed electrical connection guide.

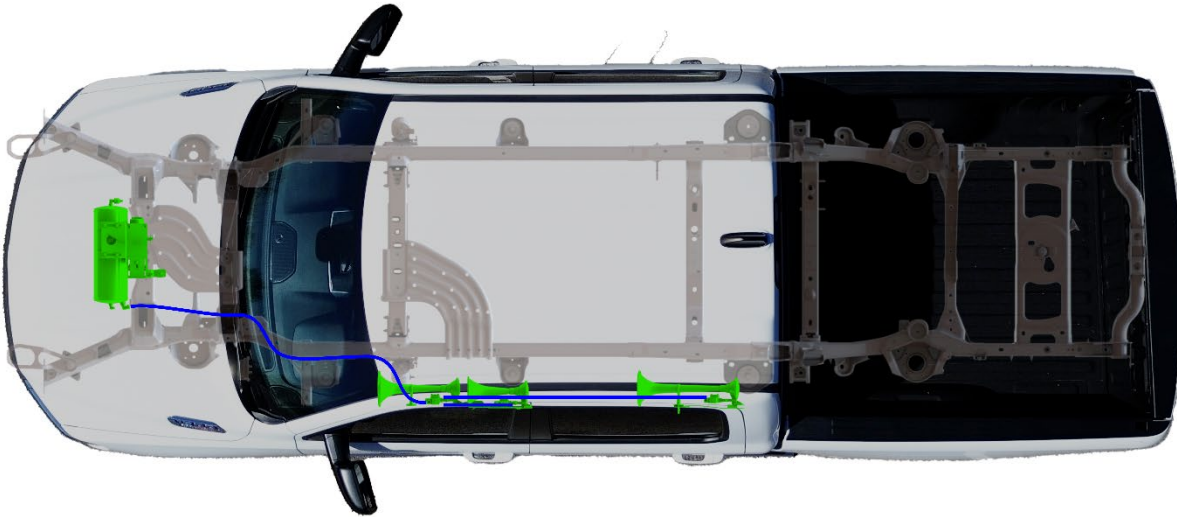
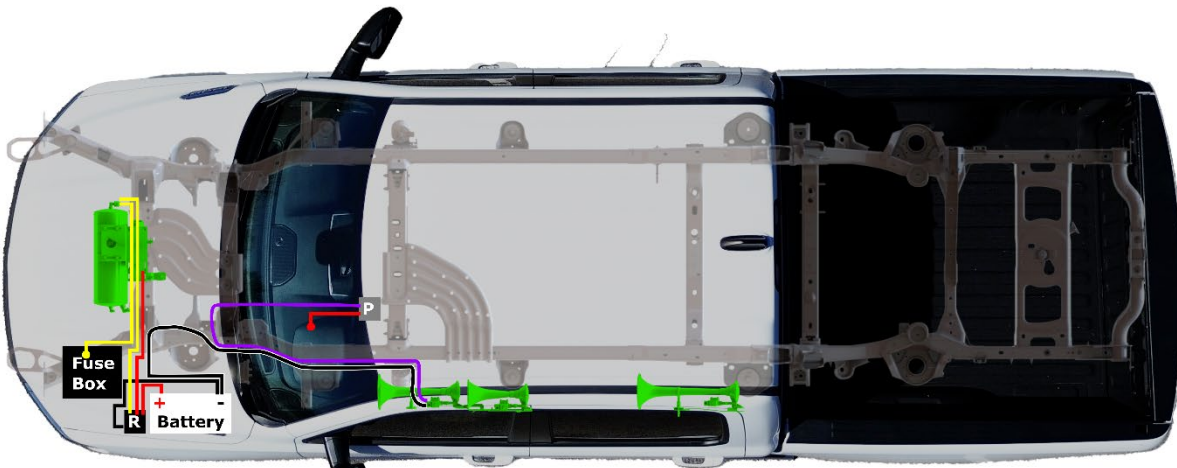

Figure 2- Recommended Air Tubing Routing



R = Relay **P** = Pushbutton
Yellow = +12v Switched **Red** = +12v Constant

Figure 3- Recommended Electrical Routing

7. Bench Assembly

7.1. Combine Upper & Lower Dual Horn Bracket

Use the below figure to assemble the Dual Horn Bracket.

NOTE: Keep the hardware slightly loose so the upper bracket can slide from side to side.

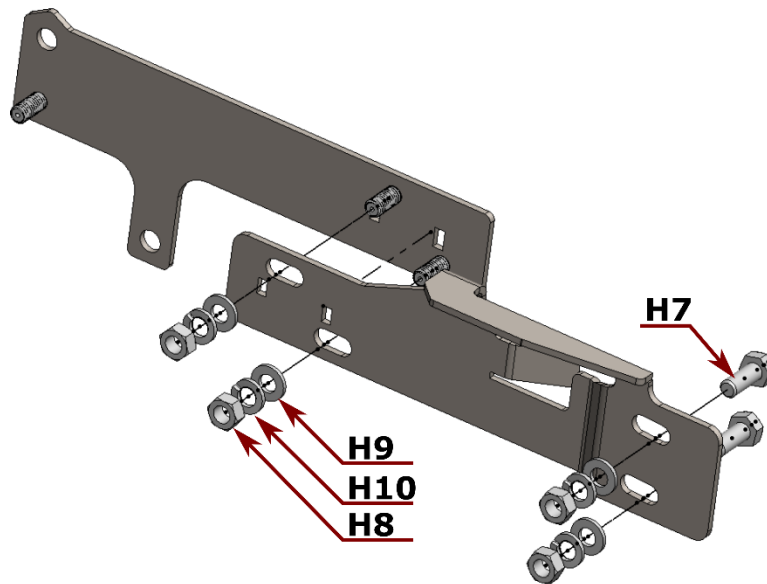

Figure 4- Dual Horn Bracket Assembly

7.2. Horn / Ore Bracket & Large Horn Preparation

Use the below figure to prepare the Horn / Ore Bracket.

- 1) Install one (1) Ore onto the ore mount on the Horn / Ore Bracket using the included hardware.

NOTE: DO NOT use the rubber bushings when installing the ore mount.

- 2) Use Qty: 2 of each hardware H7, H9, H10 & H8 and install them onto the bracket (ref below).
- 3) Separate the 3 horns from the metal bar (if attached)
- 4) Unscrew the largest horn trumpet from its base (extreme force may be required) and set aside.

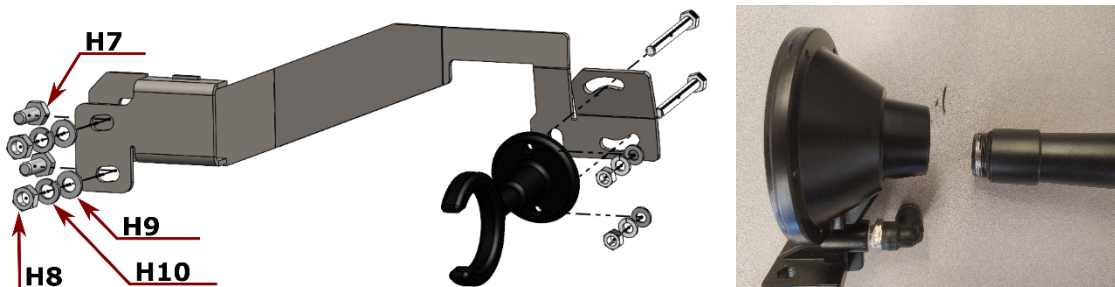

Figure 5- Horn / Ore Bracket Preparation, Large Horn Preparation

7.3. Install Tank Fittings onto Air Tank

Use the below figures to install the tank fittings onto the air tank.

- 1) Use Kleinn Juice (F7) on the male threads to provide an airtight seal.
- 2) Tighten the threads by hand, then further tighten ¼ turn – ½ turn or further to match the correct fitting orientation where applicable.

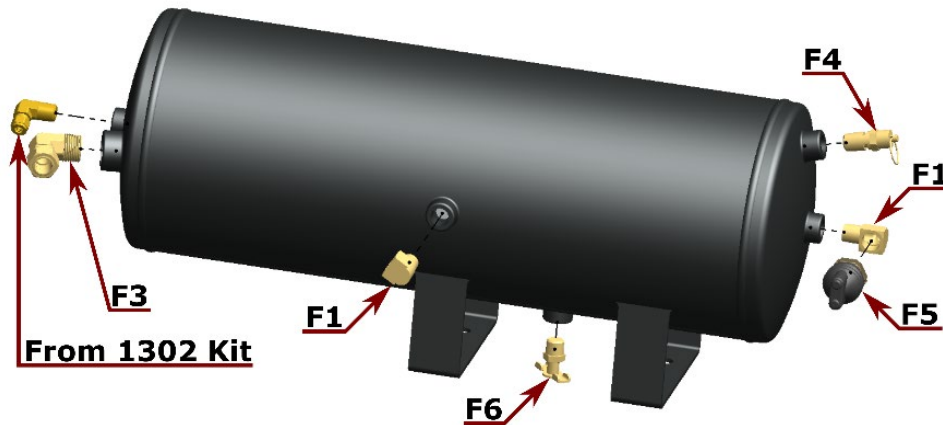

Figure 6- Air Tank Fitting Locations

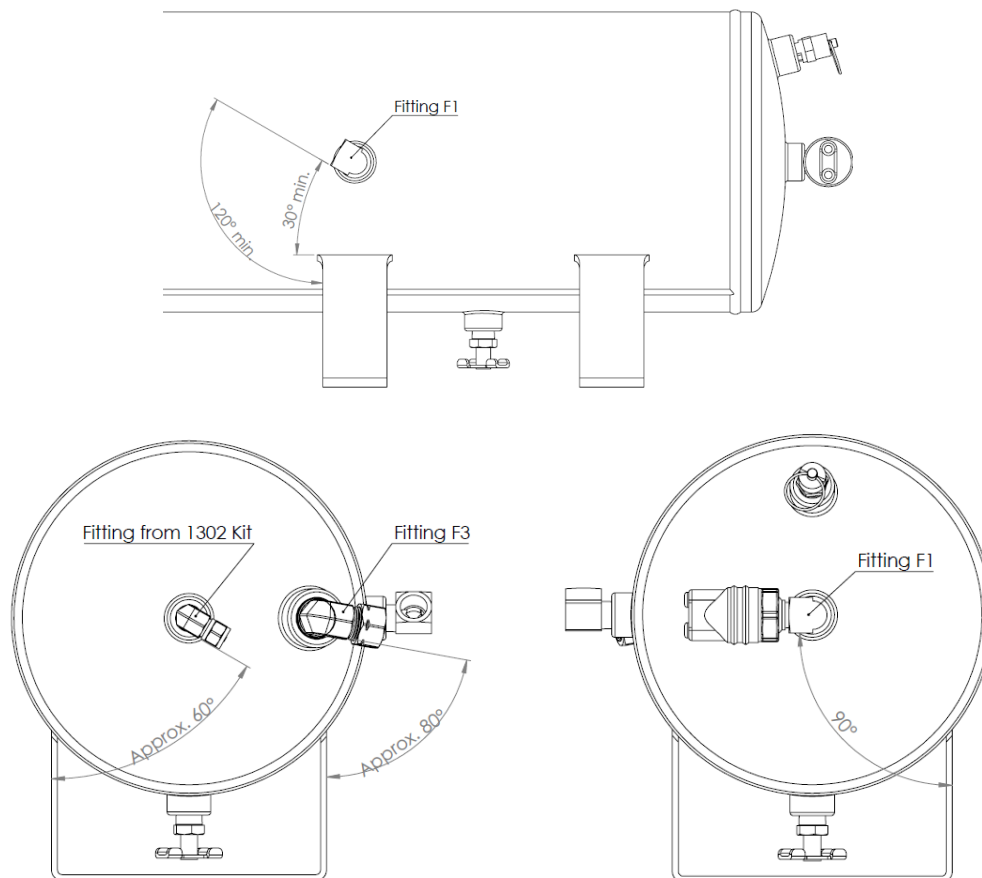

Figure 7- Fitting Orientation

7.4. Medium Horn Fitting Replacement & Solenoid Installation

For this section, the horn referenced is the medium length horn that has brass fittings attached to the base.

NOTE: Use JUICE to seal all NPT fittings.

- 1) Remove the two compression fittings from the sides of the TEE and replace with two (2) F2 fittings.
- 2) Direct the fittings straight & back, towards the rear of the horn base. Ref. the below figure.



Figure 8- Medium Horn Fitting Replacement

- 3) Unscrew the trumpet from the base and set aside.
- 4) Install the solenoid included in the horn box (small white box) onto the male NPT fitting from the horn base.

NOTE: Orientation of the Solenoid doesn't matter, so long as it is parallel to the mounting surface of the horn base.

- 1) Detach the connector from the solenoid and set aside for wiring (shown below in red).
- 2) Install the 1/2" NPT fitting (using JUICE) onto the end of the solenoid (shown below in blue).
- 3) Install the 1/4" air tubing (F8) onto the highlighted elbow fitting (shown below in green).

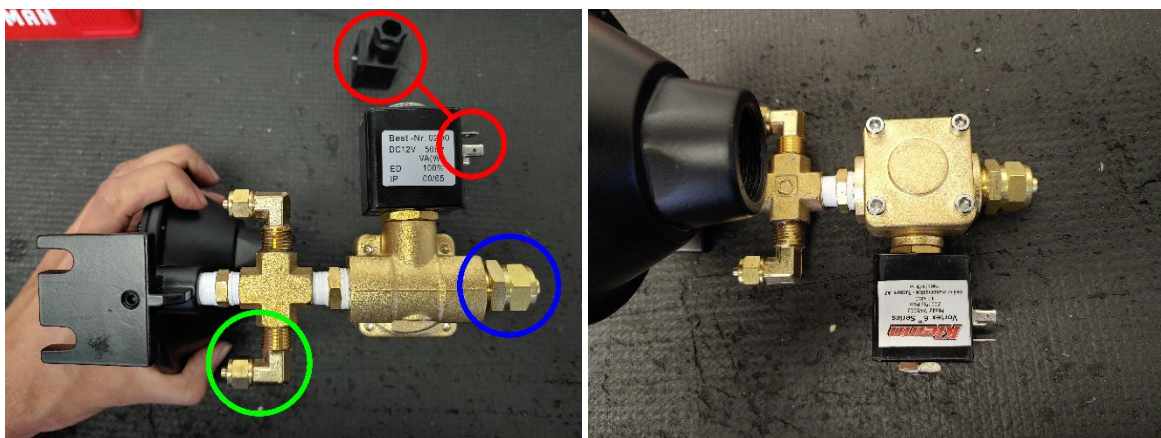

Figure 9- Medium Horn Solenoid Preparation

7.5. Assemble 1302 Kit & INF-1 Kit

Use the below figure to assemble the 1302 kit & the INF-1 Kit.

- 1) Use Kleinn Juice (F7) on the male threads to provide an airtight seal.
- 2) Take the quick connect fitting from the INF-1 kit & install onto the 1302 kit as illustrated below.
- 3) Tighten the threads by hand, then further tighten $\frac{1}{4}$ turn – $\frac{1}{2}$ turn, or until properly tightened.

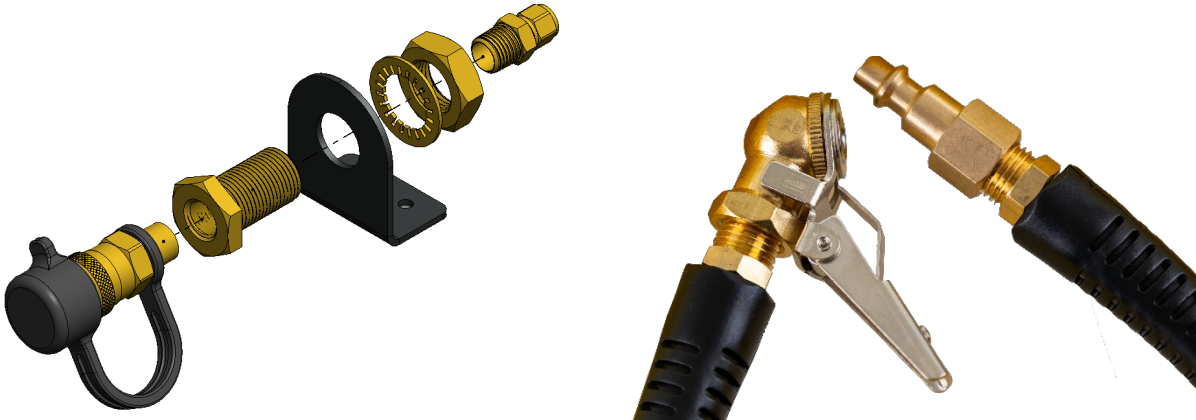

Figure 10- 1302 & INF-1 Assembly

8. On-Vehicle Assembly

8.1. Install Compressor Support Bracket

The compressor support bracket is installed behind the front bumper &, directly in-front & on top of the crossmember there. Reference the below figure.

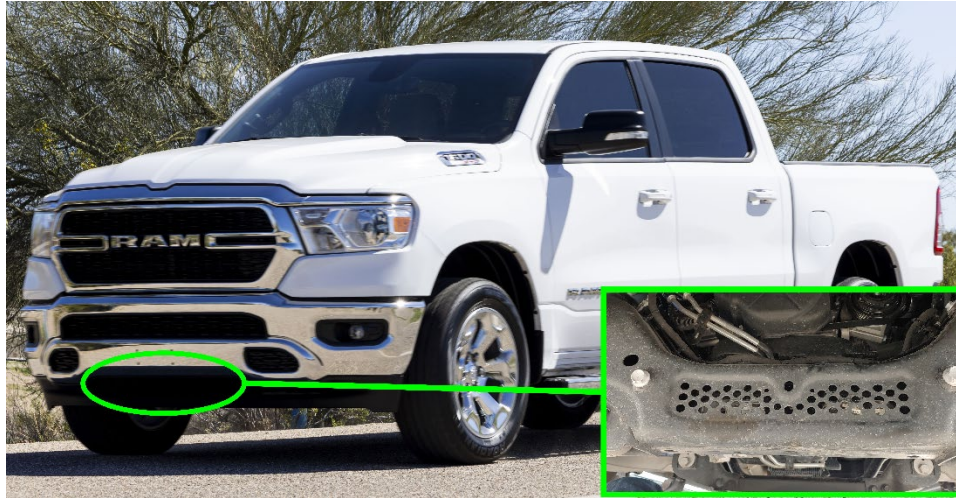

Figure 11- Compressor Support Bracket Location

- 1) Using one (1) of hardware H2, place the compressor support bracket onto the crossmember and place the bolt onto the bracket tab.
 - a. H2 can be placed onto the bracket by inserting it from the rear of the crossmember.
 - b. Seat the bolt directly on the bracket & avoid damaging the hard lines that run adjacent to the crossmember. The head of the bolt will fit underneath the hardlines.
 - c. The front lower bracket slot should align with the crossmember hole noted below.

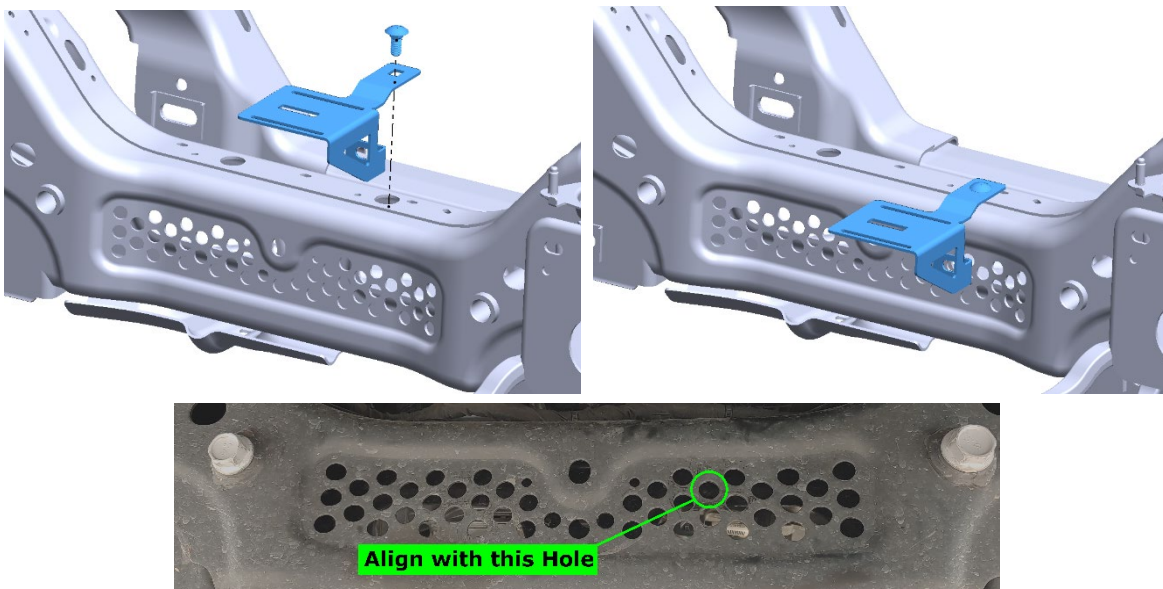

Figure 12- Compressor Support Bracket Installation 1

- 2) Using a flexible magnetic pickup tool, Insert the Cutaway Washer onto the carriage bolt from inside the crossmember. Reference the below figure.

NOTE: Orient the cutout on the washer towards the driver side & vehicle back to avoid the barbs of the plastic retaining clip.

- 3) Use hardware H4 to retain the washer in place. **Hand tighten** the nylon lock nut at this time.

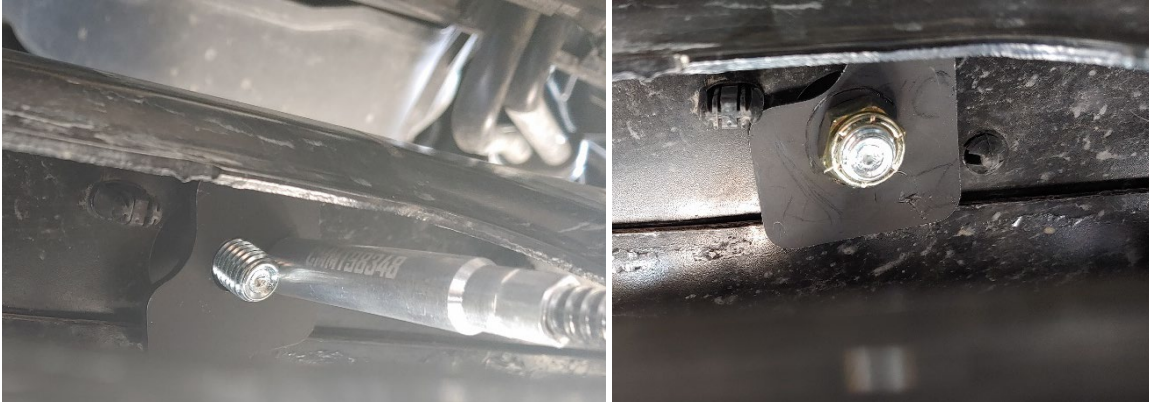

Figure 13- Cutaway Washer Installation

- 4) Insert one (1) H1 bolt from inside the crossmember and through the front hole (identified earlier) and through the lower slot on the bracket.
- 5) Fully tighten the bolt with one each of H5, H6, & H3. Reference the below figure.

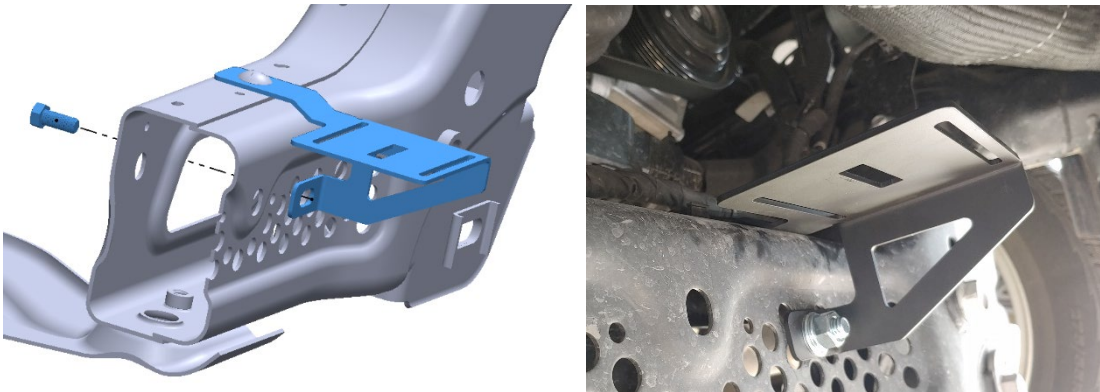

Figure 14- Compressor Support Bracket Installation 2

- 6) Fully tighten the Nylon Lock Nut (installed in Step 3) to fully secure the bracket in place.

8.2. Install Tank / Compressor & Bracket

The Tank/Compressor Bracket gets placed on top of the previously installed bracket. It gets mounted to the front of the crossmember in a similar fashion & bolts directly onto the support bracket.

- 1) Set the Tank/Compressor Bracket on top of the support bracket and align the square slots of both brackets.
- 2) Set the remaining H2 bolt into the slot, and loosely attach both brackets together using **one of each hardware** H5, H6 & H3 as shown below.

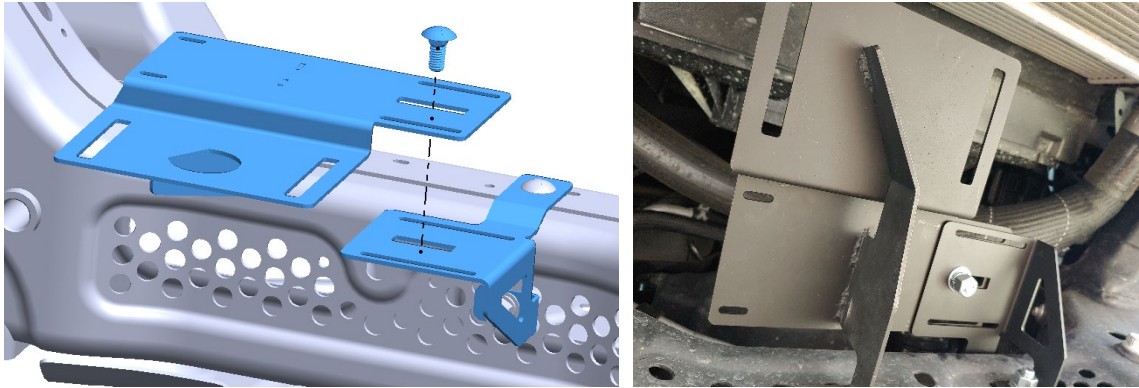

Figure 15- Tank / Compressor Bracket Installation 1

- 3) Insert one (1) H1 bolt from inside the crossmember and through the front hole (identified below) and through the lower slot on the bracket.

NOTE: Slide the bracket sideways (as needed) to align the lower slot onto the correct crossmember hole (See Below).

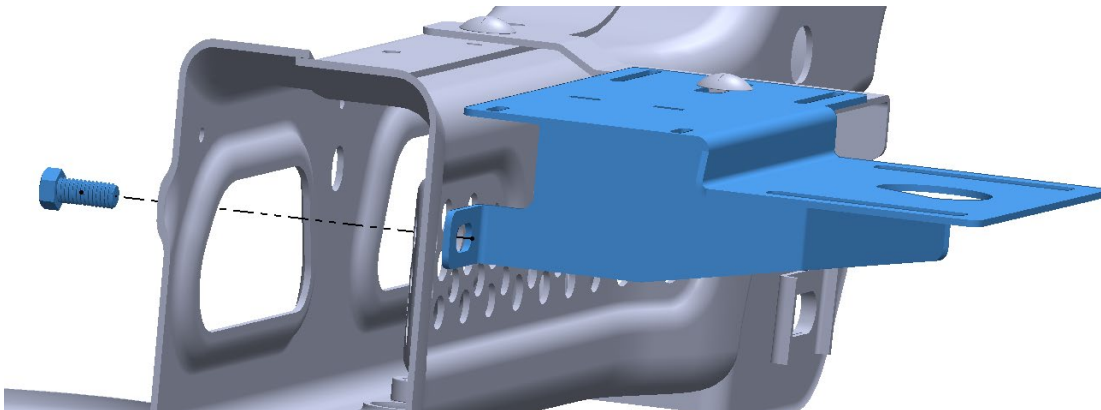
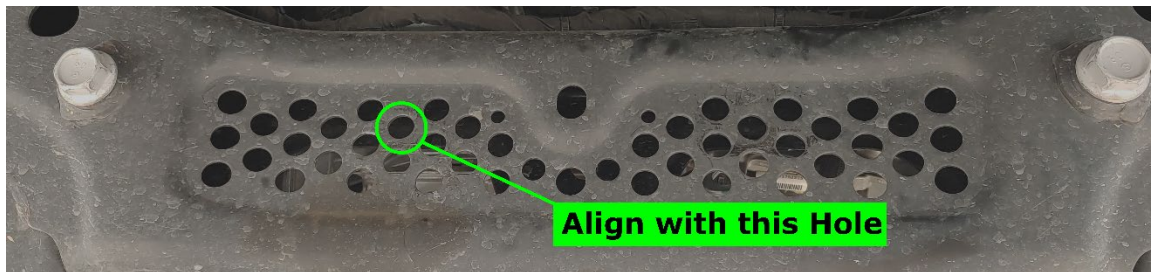

Figure 16- Tank / Compressor Bracket Installation 2

- 4) Secure the bolt with one of each hardware H5, H6, & H3, but DO NOT fully tighten the hardware at this time. Reference the below figure.



Figure 17- Tank / Compressor Bracket Installation 3

- 5) Install compressor air filter onto the compressor head, or use the directions (included in compressor box) to install & route the air snorkel kit.
- 6) Place the compressor onto the upper bracket shelf (compressor head towards passenger side) and secure in place using the hardware included with the compressor.

NOTE: DO NOT overtighten the compressor hardware or the rubber bushings will be damaged.

- 7) Adjust the brackets as needed for good fitment of the compressor, then fully tighten all bracket hardware.

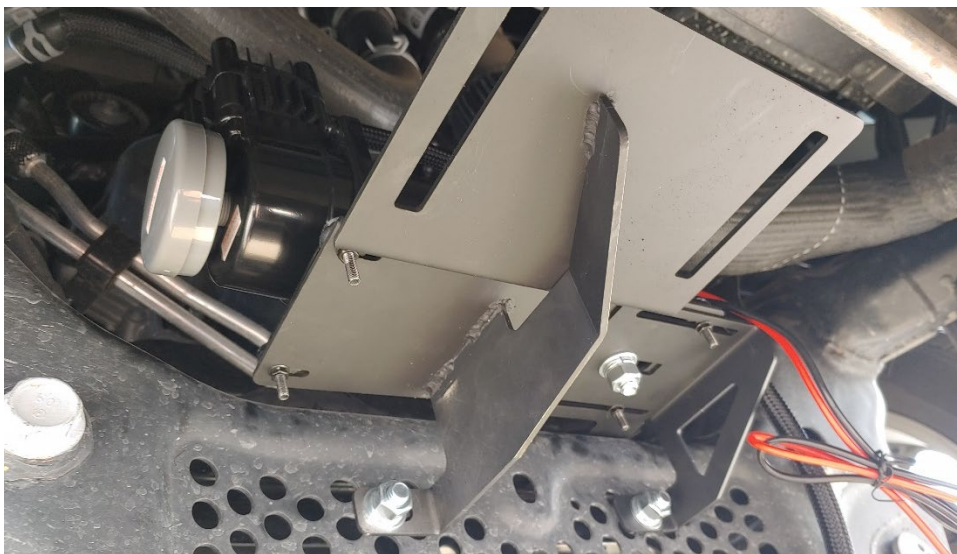

Figure 18- Compressor Installation

- 8) Place the air tank onto the lower bracket shelf (pressure switch on the same side as the compressor head).
- 9) Use four (4) of each hardware H1, H11, H5, H6 & H3 to secure the tank onto the bracket.

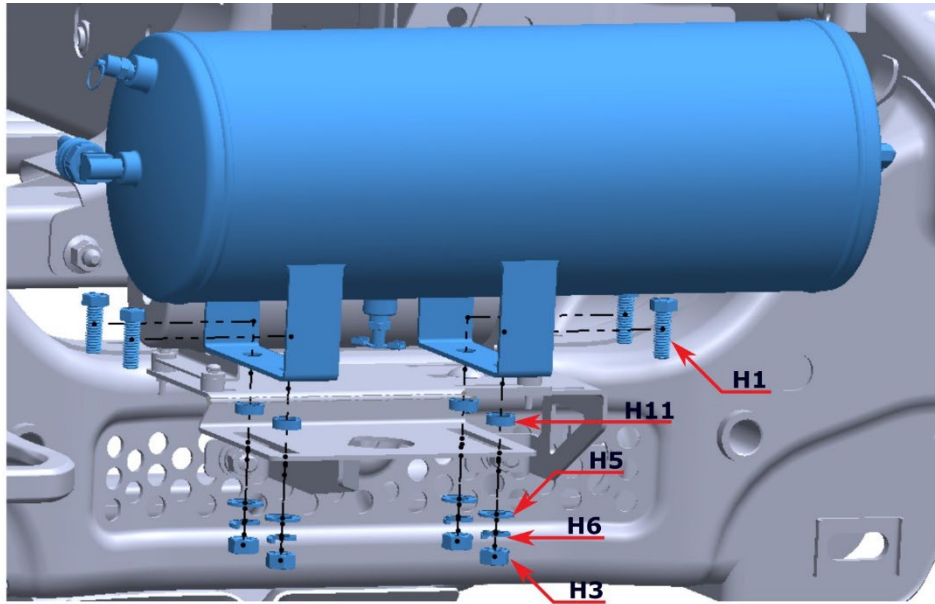

Figure 19- Tank Installation

- 10) Route the compressor leader hose behind the F1 fitting (in-between the compressor & tank) and form a loop to thread it (using JUICE) into the fitting. Ref. the below figures.

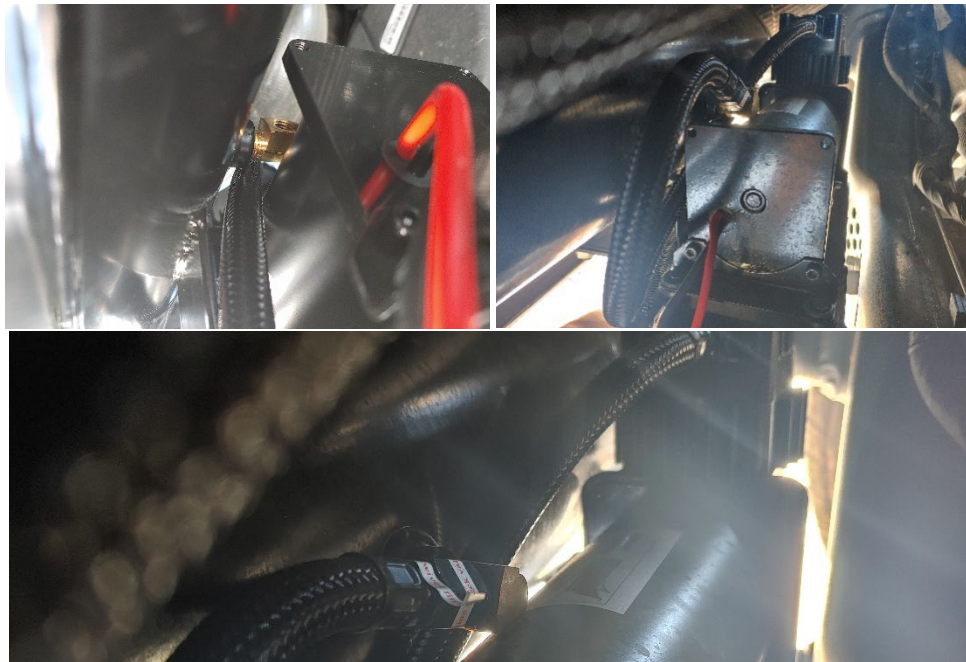

Figure 20- Tank / Compressor Plumbing

- 11) Hand tighten the leader hose end, then further tighten $\frac{1}{4}$ - $\frac{1}{2}$ turn.

8.3. Large Horn & Horn / Ore Bracket Installation

The large horn & the Horn / Ore Bracket are located on the body mounted studs directly below the rear driver side door, mounted to the cab, opposite the frame rail.



Figure 21- Large Horn & Horn / Ore Bracket Location

- 1) Remove the plastic cover that is protecting the rear slot on the body.
- 2) Loosen (if present) the upper nut & captive washer that retains the running board bracket.
- 3) Place the tab extruding from the bottom of the bracket into the slot and pivot the bracket down so the notched section of the bracket drops onto the stud & behind the nut & washer.

NOTE: If needed, tap the bracket into the slotted hole until the notch slides onto the stud.

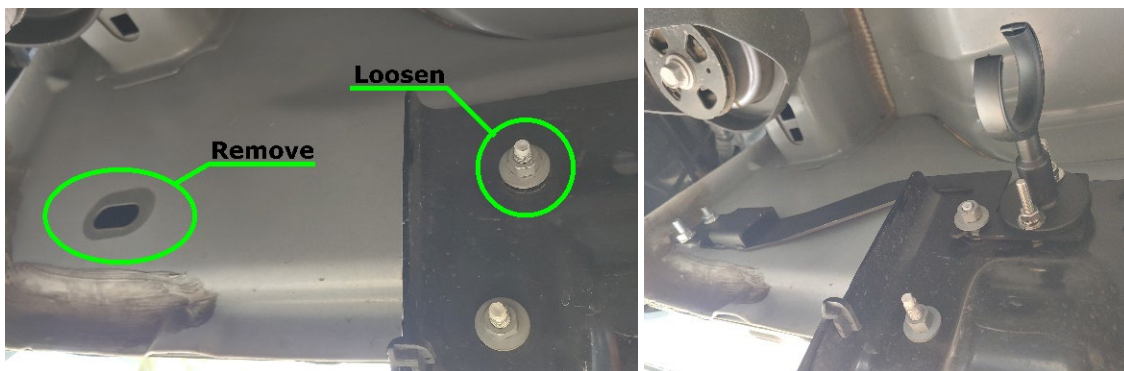

Figure 22- Horn / Ore Bracket Installation

NOTE: Perform Step 4 below ONLY if no hardware was present on the above noted stud.

- 4) Use one (1) of each hardware H8, H9 & H10 to loosely retain the bracket in position.

NOTE: Use the following Figure for the below instructions.

- 5) Using the long horn base & trumpet, guide the trumpet through the ore (towards the rear of the vehicle) and re-attach the trumpet to the horn base.
- 6) Attach the horn base onto the previously installed (See Section 7.2) hardware.
- 7) Adjust the ore so that it properly supports the trumpet, by sliding it into a secure position.
- 8) Fully tighten all the bracket & ore hardware.



Figure 23- Large Horn Installation

8.4. Dual Horn Bracket & Horns Installation

The Dual Horn Bracket and the Medium & Small Horns are located on the body studs directly below the driver door, mounted to the cab, opposite the frame rail.

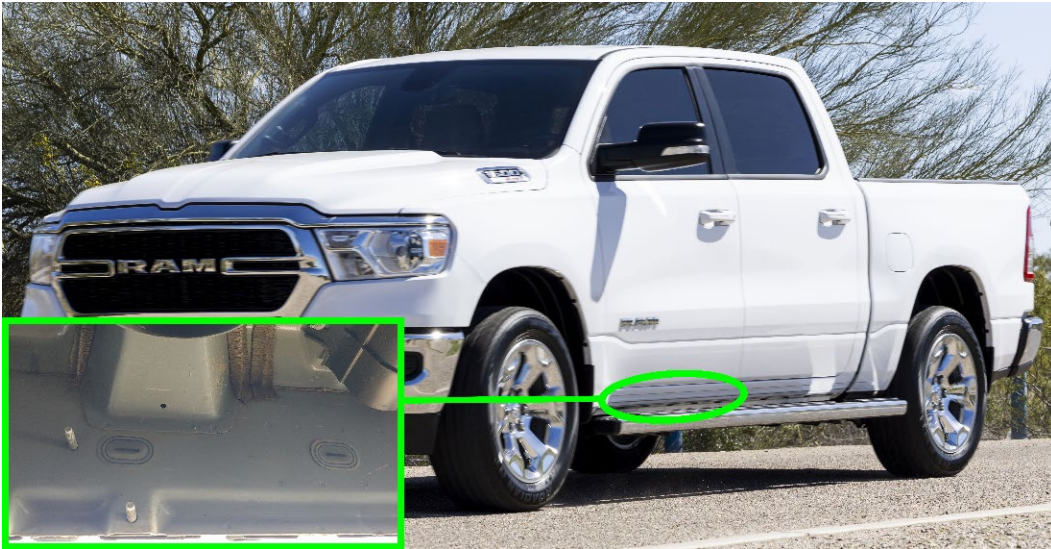

Figure 24- Dual Horn Bracket & Small and Medium Horn Location

- 1) Identify the mounting points & remove the plastic slot cover (closer to the vehicle front) shown below.

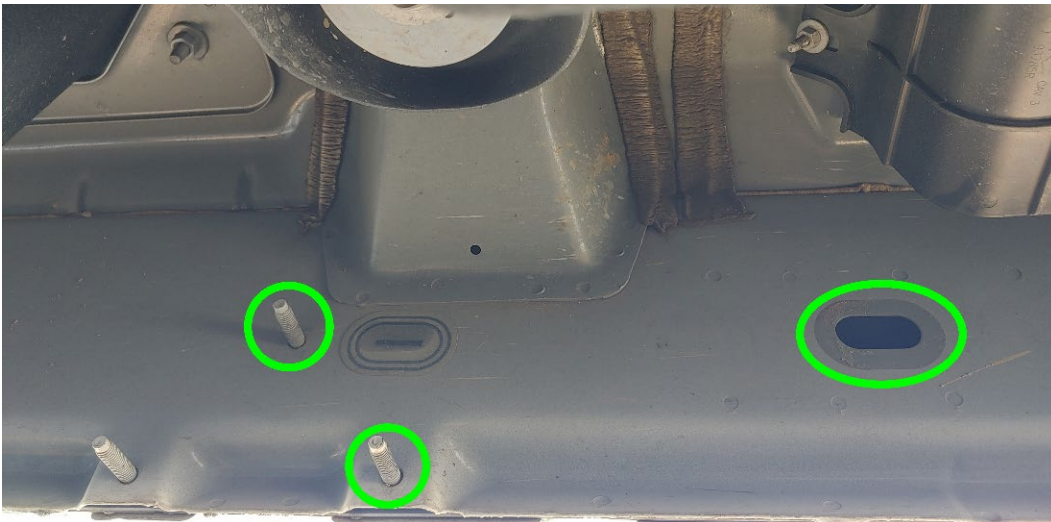

Figure 25- Dual Horn Bracket Mounting Points

- 2) Take the Dual Horn Bracket & place the bracket tab into the exposed slot & set the bracket over the middle & front body studs as shown below.



Figure 26- Dual Horn Bracket Installation 1

- 3) Extend the bracket so there is positive force to keep the bracket retained.
- 4) Fully tighten the two center nuts to keep the bracket extended.

NOTE: There are 2 cutouts in the center of the bracket which may be used to force the two halves apart with a screwdriver (see below).



Figure 27- Dual Horn Bracket Installation 2

- 5) Use one (1) of each hardware H8, H9, & H10 onto the lower stud (shown below) to secure the bracket into place.

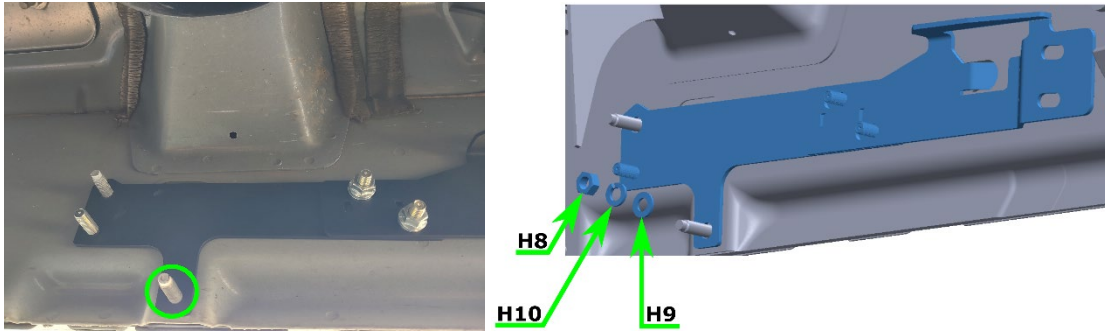

Figure 28- Dual Horn Bracket Installation 3

- 6) Use two (2) of each hardware H9, H10, & H8 to secure the small horn onto the rear studs of the bracket.
- 7) Install the medium horn onto the front part of the bracket, where the existing hardware has been installed in previous steps.
- 8) Position the horns so that they do not interfere with any vehicle parts & fully tighten all bracket and horn hardware.



Figure 29- Small & Medium Horn Installation

8.5. Plumbing

- 1) Route the air tubing to all the fittings as desired. The below figure illustrates a routing path for the air system, but you may deviate & route your air tubing as you see fit.

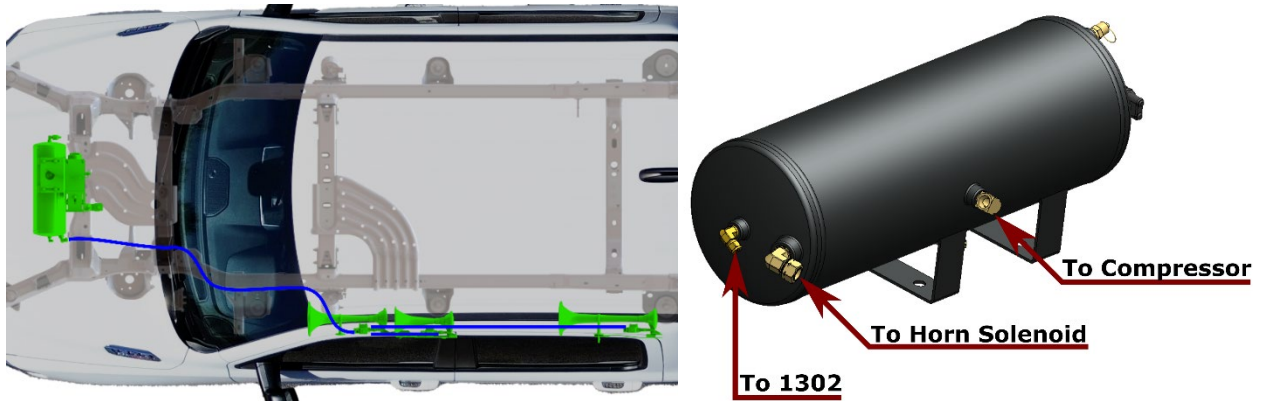

Figure 30- Plumbing, Recommended Routing & Fitting Identification

- 2) Use the 1/4" air tubing from the 1302 kit & install it onto the air tank 1/4" compression elbow.
- 3) Route the tubing & mount the 1302 Relocation Kit as desired.

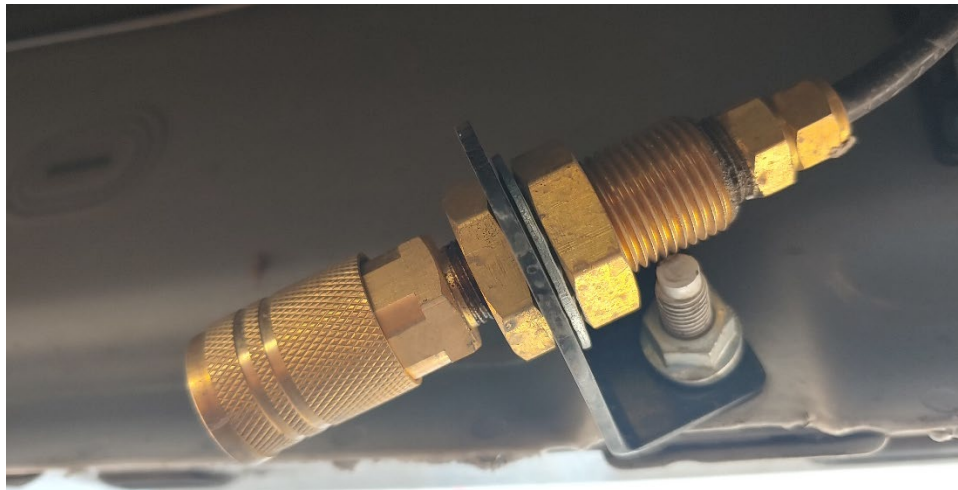

Figure 31- Example, 1302 Installed

9. On-Vehicle Electrical Installation

It is recommended to disconnect the vehicle battery prior to performing any electrical work.

9.1. Reconfigure the Solenoid Connector Housing

Use the below figures to reconfigure the solenoid connector for optimal wire routing & fitment.

- 1) If not already detached, remove the electrical connector from the solenoid.
- 2) Remove the rubber boot to expose the separation slot.
- 3) Use a small pry tool to separate the connector from the housing.



Figure 32- Solenoid Connector Housing, Disassembly

- 4) Flip the housing over to the desired angle.
- 5) Hookup the Black & Violet wires to the highlighted terminals. Either wire can connect to either terminal.

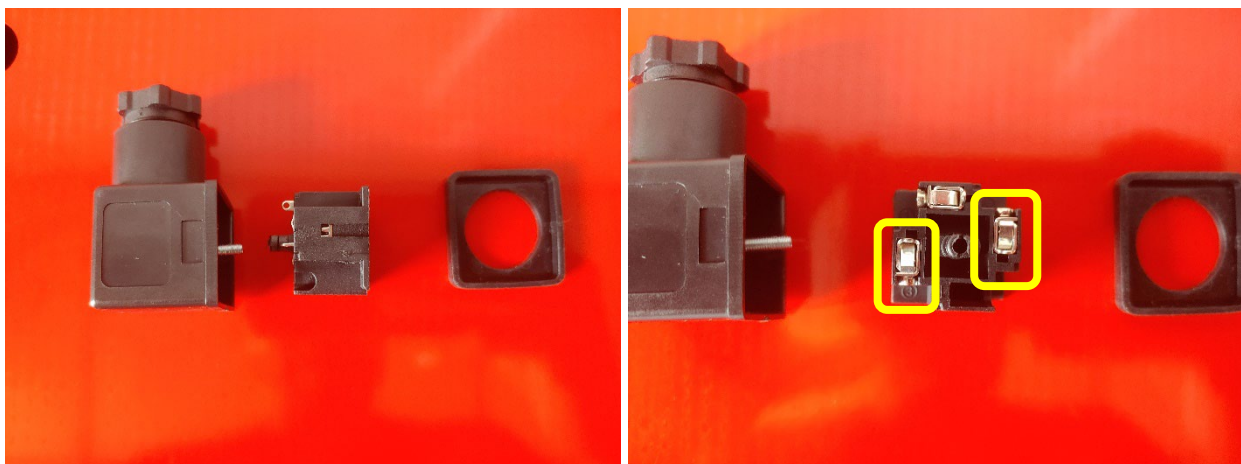

Figure 33- Solenoid Connector Housing, Exploded View & Terminal Identification

- 6) Reassemble the connector.
- 7) Install the connector back onto the solenoid.

NOTE: It is recommended to use the included loom for all wiring applications.

9.2. Attach Relay & Fuse to Vehicle

Locate a suitable location under the hood and install the fuse housing & relay.

- For the Fuse: Select an area close to the POS (+) battery terminal
- The fuse housing can be attached to the vehicle body panel using the supplied screws
- The relay can be attached to the vehicle body using the supplied self-tapping screws

9.3. Install Horn Button

Locate a desirable & accessible location to install the horn button. There should be a minimum of 1" clearance behind the switch location to allow for the switch to be mounted and wired easily.

Factory upfitter switches may be used at the installers/customers discretion. Consult the owners manual or OEM documentation if using this option.

9.4. Route Wiring & Make Connections

Route wiring as desired and make the appropriate connections (REF. the below figures). Use the included wiring loom and crimp connectors as desired.

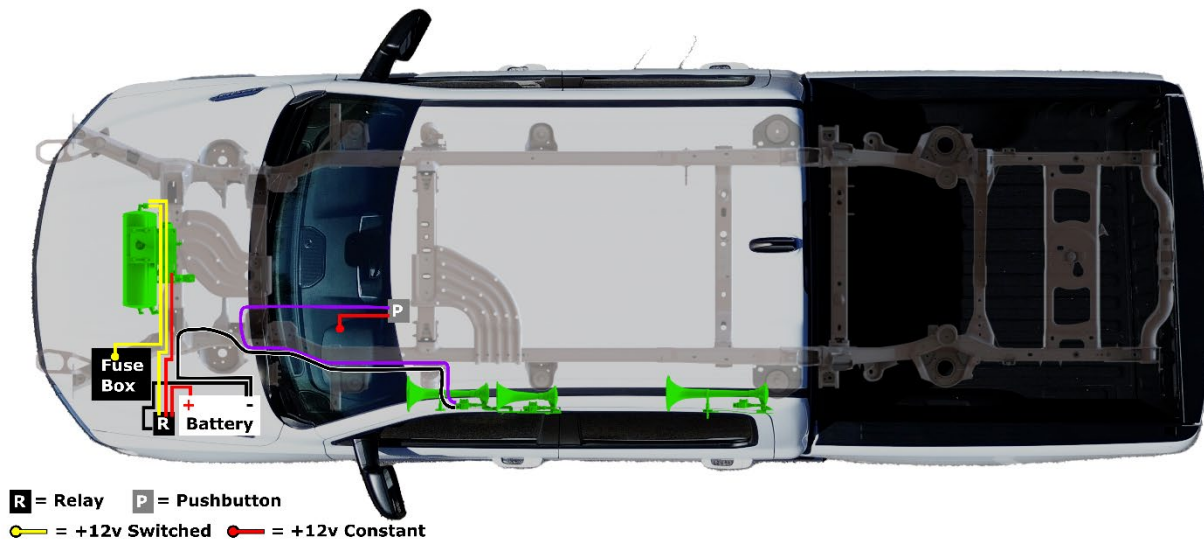

Figure 34- Electrical, Recommended Routing

--Continue to the following page for a connection diagram--

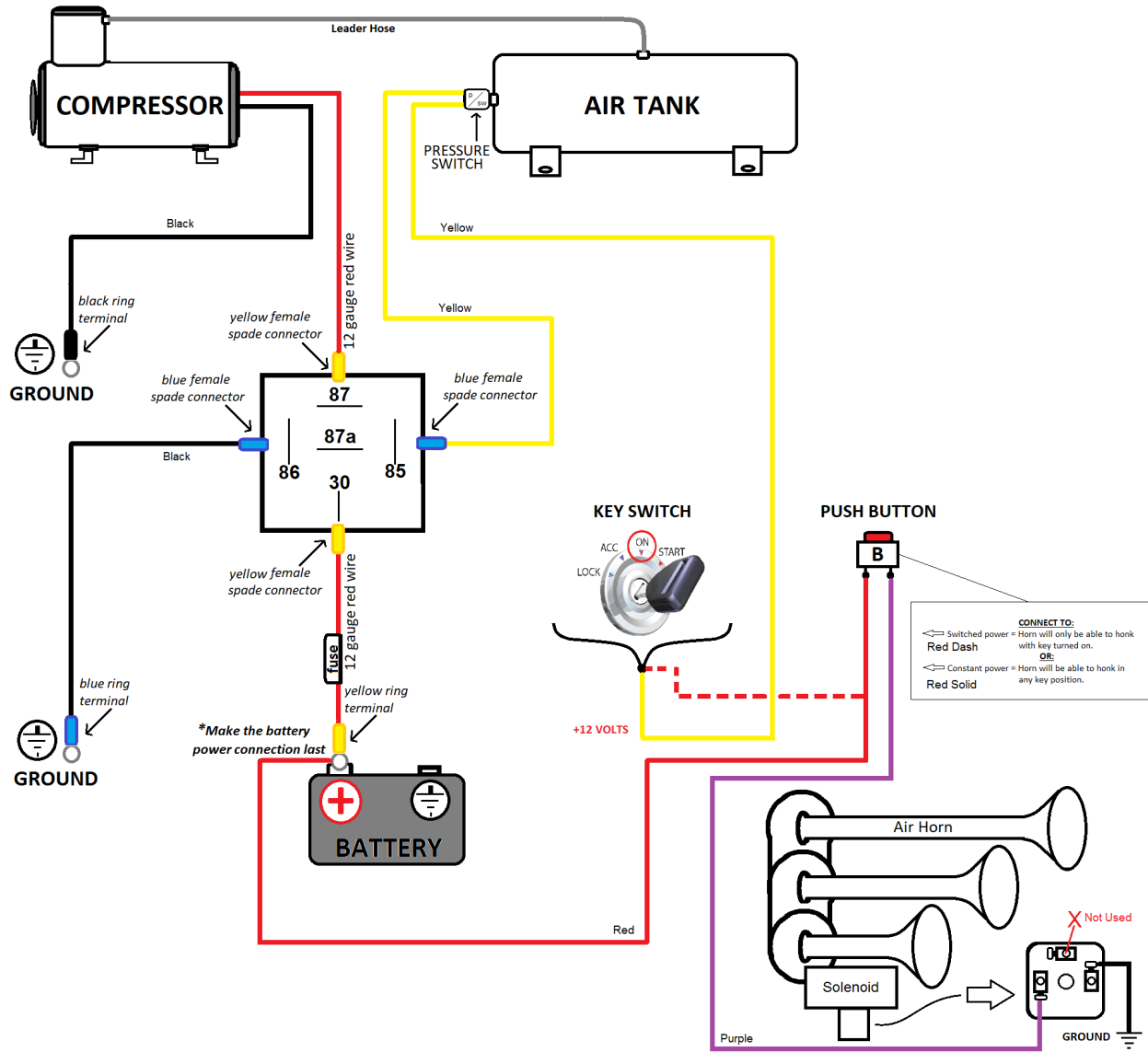

Figure 35- Wiring Diagram

9.5. Wrapping Up

Re-attach the medium horn trumpet to the horn base.

10. Testing the Air System

It is recommended to check your wiring for shorts & continuity & double checking your connections prior to reconnecting the battery.

It is recommended to check the drain valve on the tank and ensure it is fully closed.

10.1. Air Compressor Test

1. Start the vehicle & allow the air compressor to run and fill up the tank.

NOTE: The compressor should turn off after tank reaches \approx 150 PSI. This should take between 2-5 minutes. If the compressor runs excessively, a leak may be present in the system.

2. Allow the tank to drain via, the horns (if installed), the Inflator kit, or the tanks drain valve.
3. Wait for the compressor to start up again to replenish the air supply.
4. Wait for the compressor to turn off when tank is fully pressurized.

10.2. Air Horn Test

Ensure all persons nearby have adequate hearing protection & provide courtesy warning to neighbors before testing the horn system.

!!WARNING!! NEVER operate the air horns with ears in close proximity to the trumpets or in an enclosed space without SUBSTANTIAL HEARING PROTECTION for all persons closer than 50 feet from the vehicle.!!

1. Activate the air horns by pressing the horn button briefly. Horns should sound as expected and be loud.

The horn sound & loudness will diminish as the air tank loses pressure. Repeat, if desired, until the compressor turns on and begins refilling the air tank.

10.3. Quick Connect Coupler Test

The quick connect coupler can be used to run the included INF-1 tire inflator kit or certain air tools.

1. If needed, allow the air compressor to refill the air tank.
2. Attach the INF-1 inflator kit and inflate tires
3. Optionally, an air blow gun/nozzle or an air nailer can be used to test the quick connect coupling.

11. Maintenance

!!WARNING!! Operating the air compressor above its maximum pressure rating may damage the internal components and/or cause unsafe system conditions. It is recommended not to exceed 150 PSI pressure in the system.!!

This air compressor is equipped with automatic thermal overload protection. If thermal overload is triggered, the safety circuit will reset after 30 minutes.

This air compressor is oil-less, never lubricate or add liquids to this compressor.

Monthly or every 10 Hours of Compressor Use:

- Drain the moisture from the air tank via the tank's drain valve.

Yearly or 12,000 Miles

- Replace the compressor's air filter element. – Replacement frequency depends on operating & environmental conditions.
- Remove road grime or mud from components & brackets.
- Inspect all mounting fasteners to ensure they remain secure. Tighten as needed.
- Inspect electrical connections & loom for damage. Repair/Replace as needed.

12. Warranty Information

Thank you for purchasing this Air System. If you experience any unexpected problems during installation, or part failure at any time, please contact KLEINN Support.

KLEINN MANUFACTURER LIMITED DEFECT WARRANTY:

Kleinn Automotive Accessories warrants this product to the end-user, when properly installed and under normal conditions of use, to be free from defects in workmanship and materials for a period of one year from the provided date of purchase to the original purchaser of the product. This warranty does not cover abuse, operation in a manner inconsistent with the product's design, or damage resulting from exposure to the elements. If the defect is considered "under warranty", Kleinn will, at its option, repair or replace the product free of charge to the original purchaser. Kleinn is not liable for any installation charges, loss or damage of any kind incurred in the replacement or repair of any warranted product.

© Kleinn Automotive Accessories 2019, All rights reserved.

PO Box 91278 Tucson, AZ 85752

Phone: [\(520\) 579-1531](tel:5205791531)

Web: www.Kleinn.com



Install Guide

RAM19-734

Record of Revisions

Revision	Description	Date	Approval
Beta	Beta Launch Development	3/8/2024	AG
Beta 0.1	Added hardware H11 in Section 5.5 Updated Section 8.2, Step #9 Updated Figure 19 Updated logo Updated color template	4/15/2024	AG