



USTL-OBA

Install Guide

Revision: A

© Kleinn Automotive Accessories, All rights reserved.

Phone: (520) 579-1531

Web: www.Kleinn.com



Table of Contents

1.	Application Chart.....	3
1.1.	List of compatible vehicles	3
1.2.	Incompatible Vehicle Features & Trim Packages	3
1.3.	Aftermarket Product Compatibility	3
2.	Before You Start	3
3.	Kit Layout & Location	3
3.1.	On-Board Air (OBA)	3
4.	List of Tools & Supplies.....	4
4.1.	Required Tools.....	4
4.2.	Specialty Tools	4
4.3.	Consumables	4
5.	Parts List	5
5.1.	Primary Kit Components.....	5
5.2.	Fittings & Related Items	5
5.3.	Electrical Components & Related Items.....	5
5.4.	Mounting Brackets	6
5.5.	Hardware & Related Items	6
6.	Layout Identification	7
7.	Bench Assembly	8
7.1.	Compressor Installation.....	8
7.2.	Air Fittings Installation.....	10
7.3.	Tank Installation	11
7.4.	Finishing Touches	13
8.	Electrical Connections	14
9.	On-Vehicle Assembly.....	15
10.	Testing the Air System	16
10.1.	Air Compressor Test	16
10.2.	Quick Connect Coupler Test	16
11.	Maintenance	16
12.	Warranty Information.....	17



1. Application Chart

This kit is a direct bolt-on aftermarket product. The vehicles listed in the below table are considered to be compatible with this aftermarket kit. Every effort has been made to verify fitment on these vehicles in their factory condition.

NOTE: Before unpacking your kit, review this manual in full & verify the correct space & mounting locations exist with your trim package.

1.1. List of compatible vehicles

This kit is universal. Vehicle compatibility can be determined by reviewing this install guide.

NOTE: Drilling holes may be required for installing ground wires and switches based on installers preference.

1.2. Incompatible Vehicle Features & Trim Packages

This kit may not be compatible with the following vehicle features / trim packages:

- All OEM chassis cab frames with service boxes or flat beds, as purchased from dealerships.

1.3. Aftermarket Product Compatibility

This kit has been designed to be compatible with the following products from leading manufacturers:

- N/A

This kit has not been designed to be compatible with the following products:

- N/A

2. Before You Start

Read this manual in its entirety before starting installation. Verify you have all the parts listed & that you clearly understand the installation procedure. Contact KLEINN Technical Support with any questions you may have.

Installation of this kit requires moderate mechanical aptitude.

Use the proper tools, supplementary lighting, and safety equipment when installing this kit.

3. Kit Layout & Location

3.1. On-Board Air (OBA)

Item No.	Description	Mounting Location	Approx. Install Time
1	6450RC Air Compressor	On bracket – 2 Options Available	15 min
2	6350RT Air Tank	On bracket	30 min
3	1301 Single Needle Dash Panel Gauge Kit	To be determined by Installer/Customer	N/A
4	1302 Relocation Kit	To be determined by Installer/Customer	N/A

Note: Wiring time is not factored into the overall install of this kit.

4. List of Tools & Supplies

4.1. Required Tools

- Mechanic's 1/4" & 3/8" Drive & Socket Set – Imperial & Metric
- Combination wrenches – Imperial & Metric
- Hex wrenches – Imperial & Metric
- Screwdriver Set – #1, #2
- Wire Cutters
- Wire Strippers
- Wire Crimpers
- Utility Knife or Equivalent
- *Magnetic Retrieval Tool*

4.2. Specialty Tools

- 1/4" & 3/8" Universal Joints
- 1/4" & 3/8" Extensions
- Multimeter, Test Light, or Equivalent
- Heat Gun
- Trim Panel Removal Tools
- Drill Driver & Bits
- Impact Driver & Bits

4.3. Consumables

- Quality Electrical Tape
- Medium Strength Thread Locker
- Sandpaper, Wire Brushes or Equivalent
- Extra Zip Ties
- Touch-up Paint









5. Parts List

Unpackage & organize the kit contents and verify all parts listed below are included. Contact KLEINN Support if any questions arise.



5.1. Primary Kit Components

See Section 3 for Primary Kit Components

5.2. Fittings & Related Items

In Fitting Pack	F1.	1	52835	Drain Valve, ¼" NPT Male	
	F2.	1	52175	Safety Release Valve 175 PSI ¼" NPT Male	
	F3.	1	2151	Sealed Pressure Switch 110 PSI On / 145 PSI Off ¼" NPT Male	
	F4.	2	51414NPTL	¼" NPT Elbow	
	F5.	1	50040	Hex plug ¼" NPT	
	F6.	2	JUICE-1	Liquid Thread Sealant 2ml	
Inside INF-1 Bag	F7.	1	51414	¼" NPT Straight fitting – From 1302 Kit	
	F8.	1	51414L	¼" NPT L fitting – From 1302 kit	

The items in the above table are included in all kits.

-OBA Kit	F9.	1	51414L	¼" NPT L Fitting – Inside 1301 Bag	
	F10.	1	50050	Hex plug ½" NPT	

5.3. Electrical Components & Related Items

Item No.	Qty	Part No.	Description	Picture
E1.	1	6858	10 Gauge XL Wiring Kit	
E2.			Assorted Wire Loom	N/A

5.4. Mounting Brackets

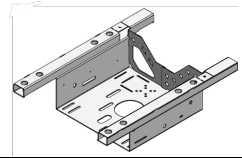
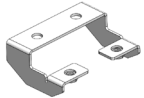
Item No.	Qty	Part No.	Description	Picture
B1.	1	USTL-10	Universal Spare Tire Bracket	
B2.	2	USTL-20	Tank Bracket	

5.5. Hardware & Related Items

Print out the hardware sheets at the end of this section at 100% Scale to facilitate hardware identification.

Item No.	Qty	Hardware Size	Description	Picture
H1.	1	7/16"-14 Kit	*4-Bolt Tank Hardware Pack (Bolts, Washers, Lock Washers & Nuts)	
H2.	4	3/8"	Split-Lock Washers	
H3.	4	3/8"-16 1" Long	Hex Head Bolts	
H4.	2	N/A	Foam Strips	N/A

6. Layout Identification

- 1) Lower and remove the spare tire from the truck.
- 2) If the spare tire is not present, lower the hoist mechanism in preparation for the kit to be installed.

NOTE: Consult the owner's manual for information regarding removal of the spare tire.

- 3) Identify if your vehicle contains an inner tire shroud as shown below.

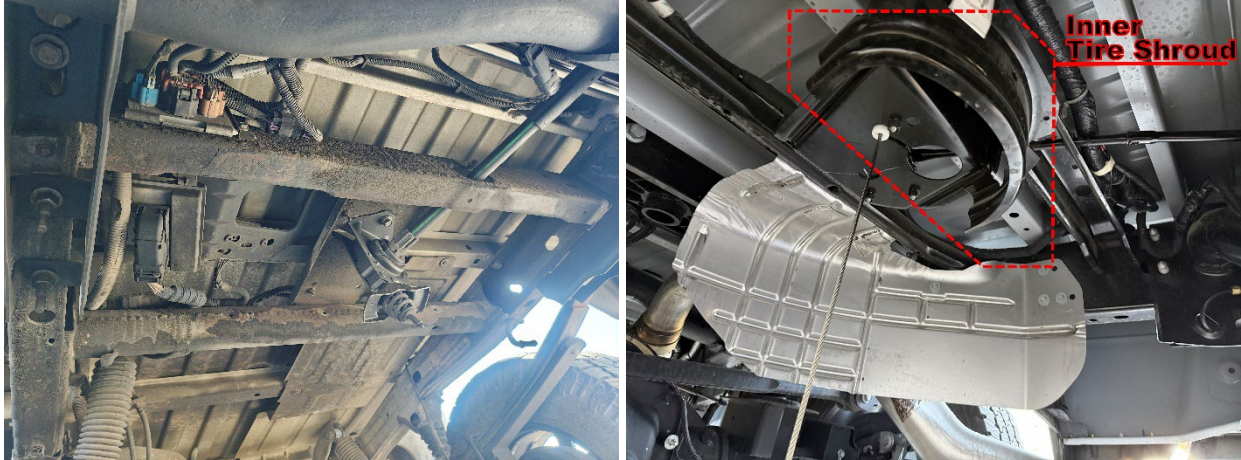

Figure 1- Under Vehicle Inspection - No Tire Shroud Left), Inner Tire Shroud(Right)

If your vehicle **DOES NOT** have the inner tire shroud, it is recommended to use **layout #1**.

If your vehicle **DOES** have the inner tire shroud, it is recommended to use **layout #2**.

7. Bench Assembly

7.1. Compressor Installation

Using the correct layout identified in Section 6, Install the compressor as follows.

- 1) Install air filter onto compressor inlet port, or follow the instructions in the compressor box to install the included snorkel kit.

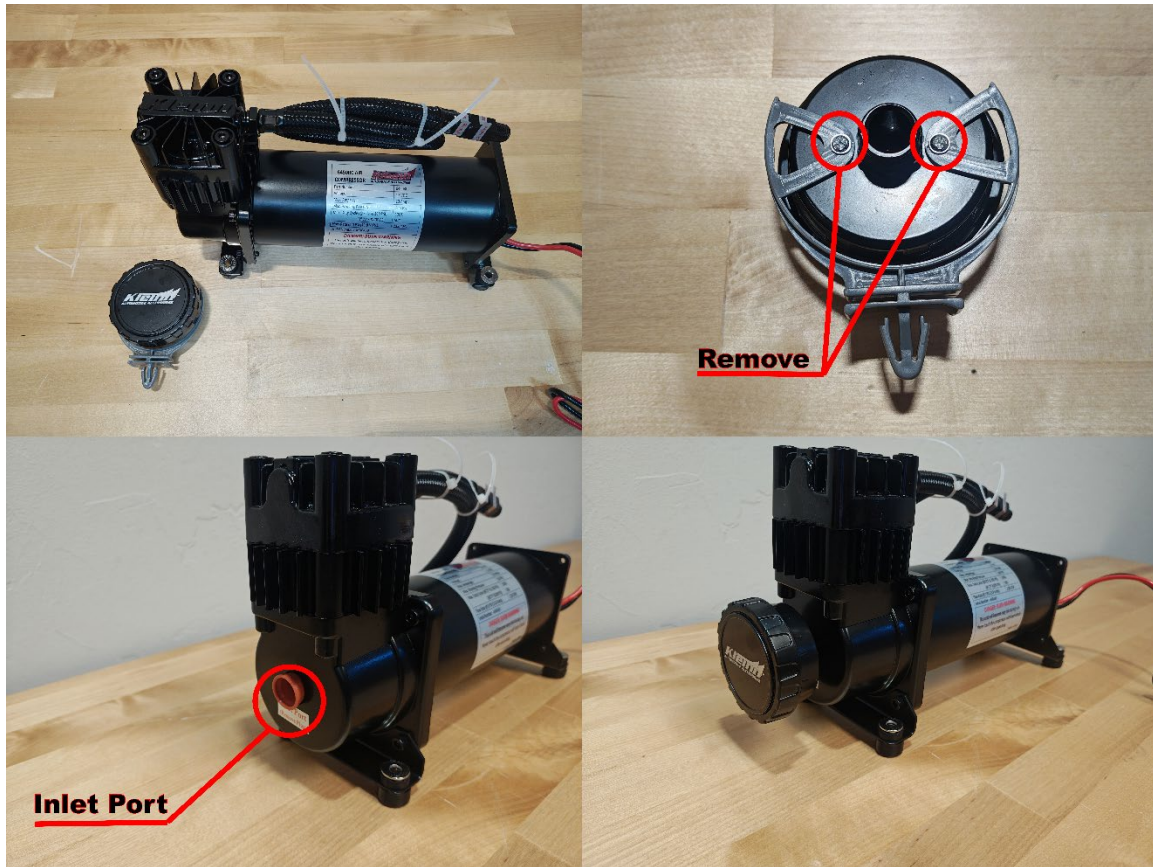

Figure 2- Compressor Filter Installation

- 2) Attach the compressor to the bracket with the hardware (*included in compressor box*) from the underside of the bracket upwards to the top of the compressor feet.
 - a. Ensure the compressor head is in the correct orientation for the layout used.
 - b. Tighten hardware to ## in-lbs/ft-lbs minimum / maximum using the stacking order noted below.



Figure 3- Compressor Installed. Layout 1 (left) & Layout 2 (right)

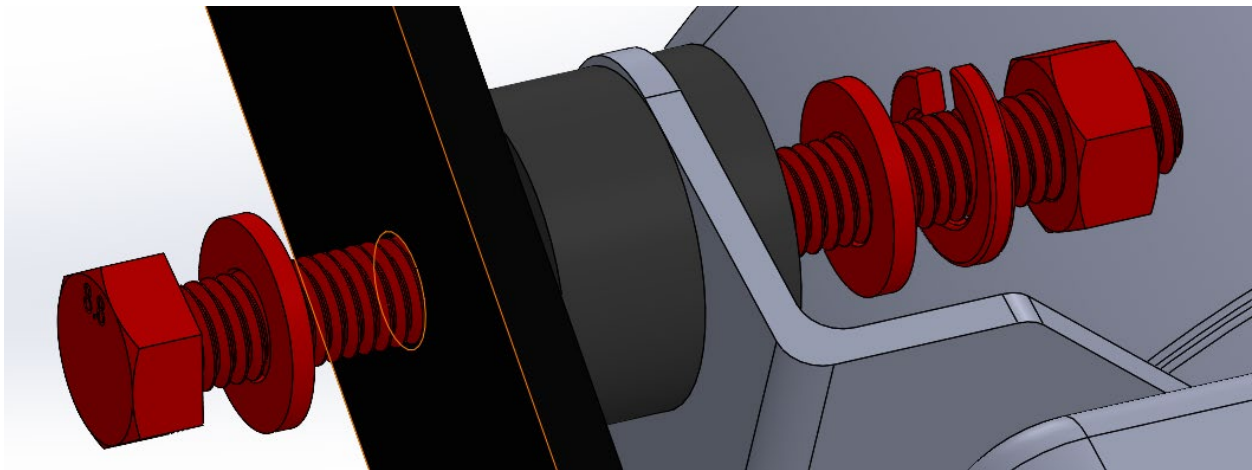

Figure 4- Hardware Stacking – Shown in Red

7.2. Air Fittings Installation

Using the correct layout identified in Section 6, Install the air fittings as follows.

- 1) Use the below figure to install the tank fittings in the correct ports.
 - a. Apply a small bead of Kleinn Juice to the male ends of each fitting for an airtight seal.
 - b. Install each fitting finger tight, then ¼ to ½ turn to match orientation as needed.

NOTE: It is acceptable to turn up to 1 full turn in order to match the fitting orientation.

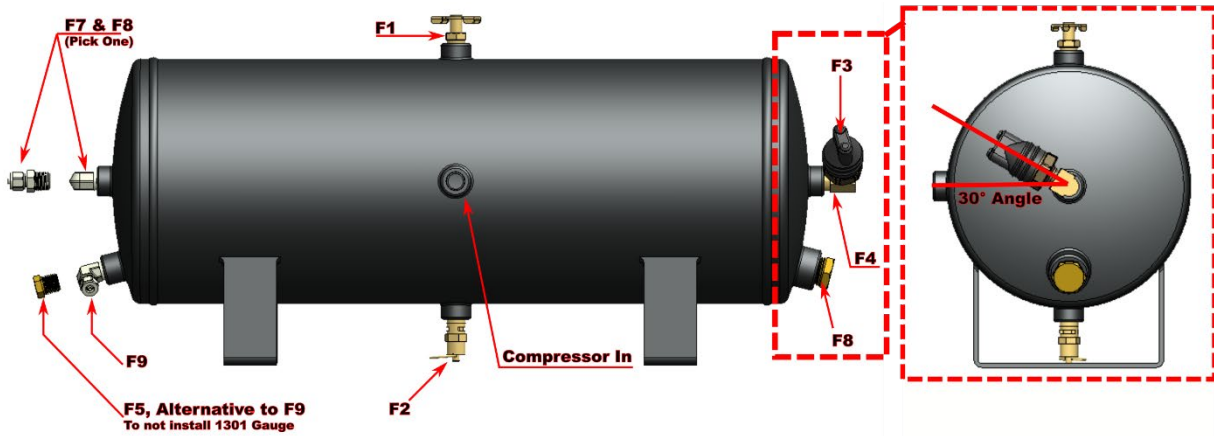

Figure 5- OBA Kit Fitting Locations - Layout #1

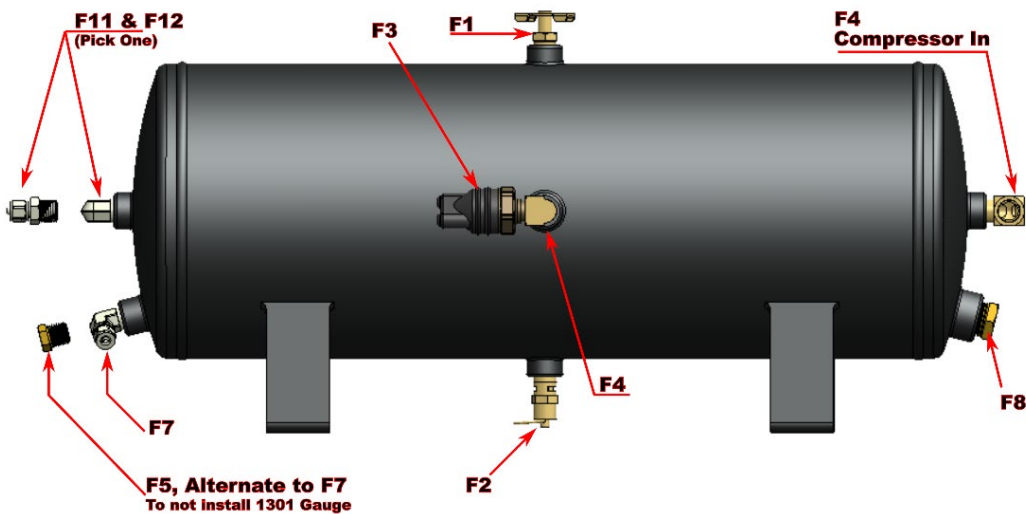

Figure 6- OBA Kit Fitting Location - Layout #2

7.3. Tank Installation

- 1) Using the separately packed 4-Bolt Tank Hardware (H1), **loosely install** the Tank Brackets (B2) inside of the tank feet as shown below. *Not all bagged hardware will be used, See hardware stacking order.*

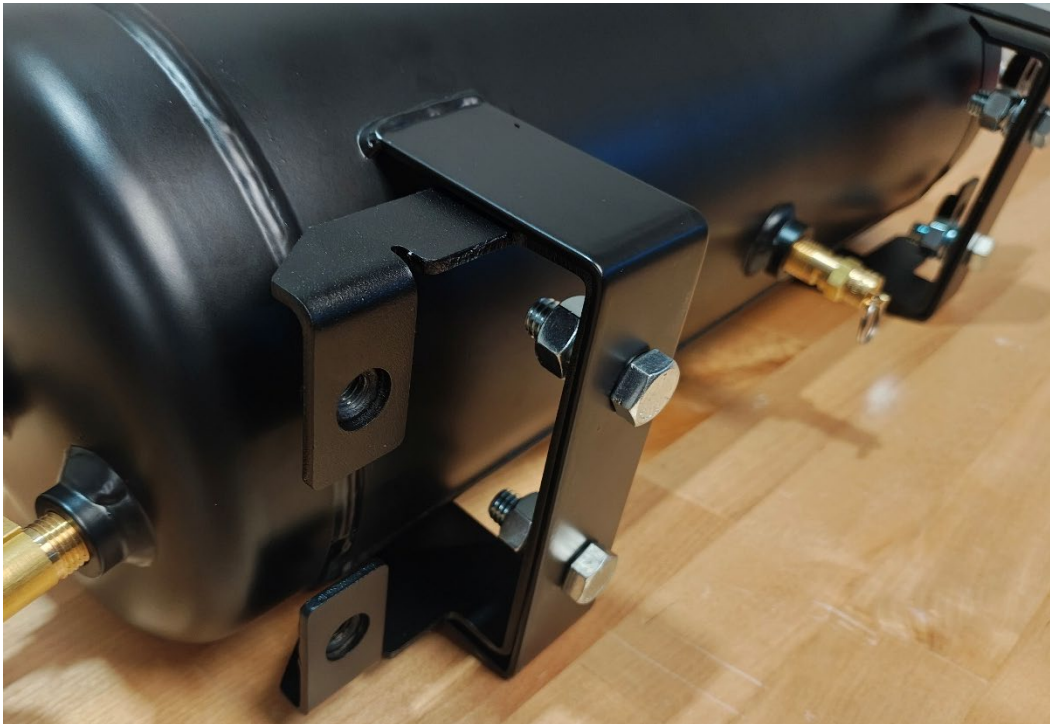

Figure 7- Tank Mounting Bracket, Placement & Installation

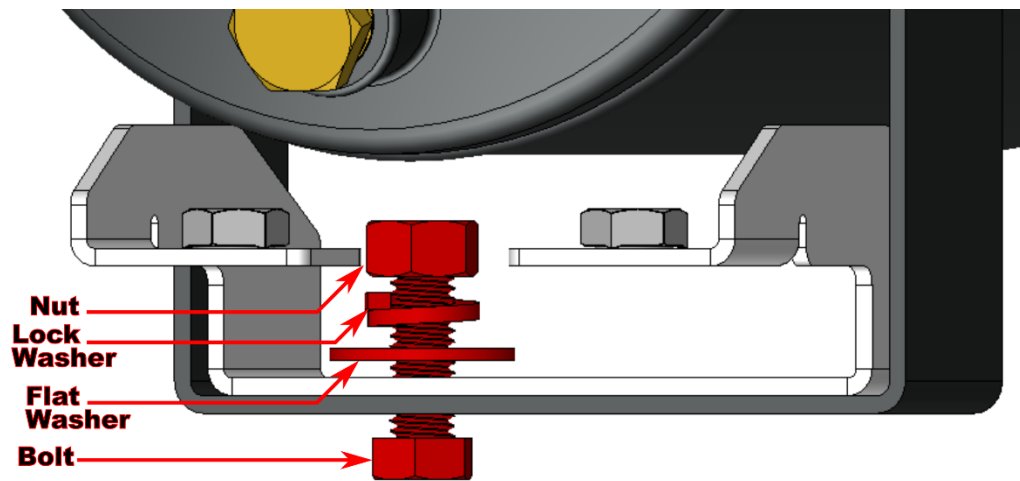

Figure 8- Tank Mounting Bracket Installation, Hardware Stacking

- 2) Set the USTL Bracket (B1) over the tank brackets & align the holes from the USTL Bracket to the weld nuts on the tank brackets.
 - a. Ensure the center NPT Port is directed to the inside of the USTL Bracket (yellow circle).
- 3) Use hardware H2 and H3 to secure the tank onto the USTL Bracket.

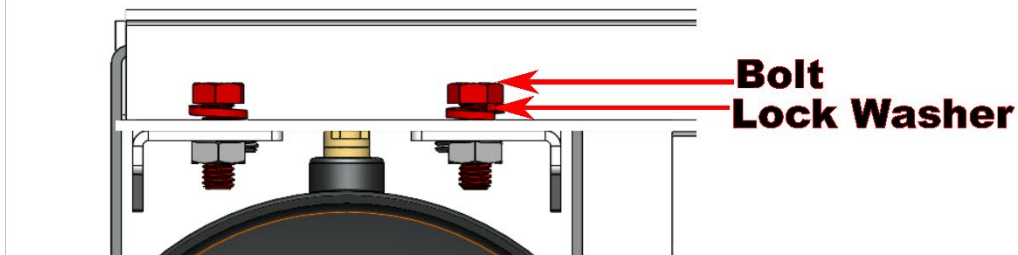
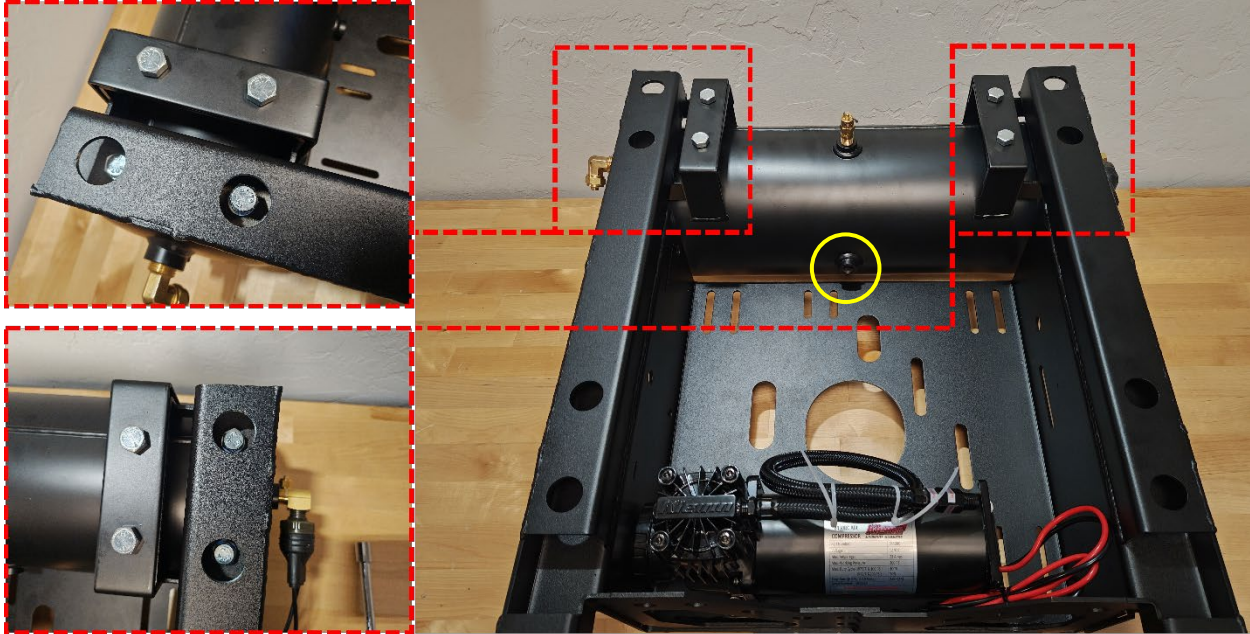

Figure 9- Tank Installed

- 4) Fully tighten the hardware H1, H2 & H3 to finish installing the tank onto the USTL Bracket.
- 5) Use some Juice and thread the compressor hose onto the tank location based on your specific layout.

7.4. Finishing Touches

Install the Foam strips (*H4*) onto the USTL Bracket arms as shown below. Trim off any excess material as needed.

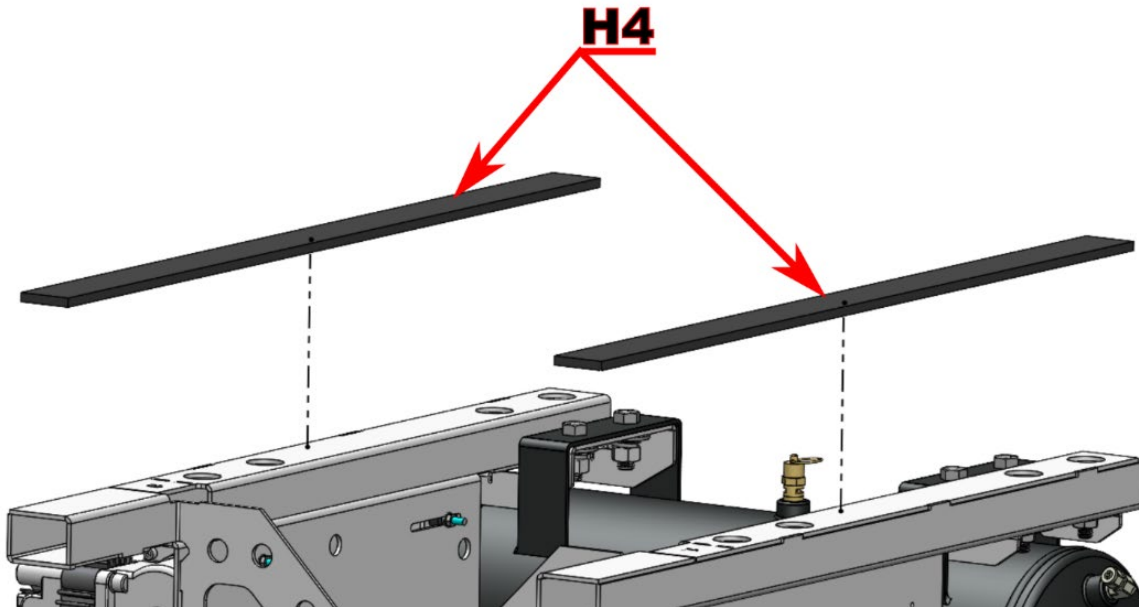

Figure 10- Foam Pad Installation

8. Electrical Connections

To facilitate on-vehicle installation, It is recommended to make as many electrical connections and/or prepare the wiring with stripping/crimping before installing the kit onto the vehicle.

The relay may be installed anywhere on the vehicle or kit, but there are specific holes on the bracket to attach the relay if desired. See below.

NOTE: Use the included Split Loom as needed to protect wire during routing and installation.



Figure 11- Relay Installation - USTL Bracket Option

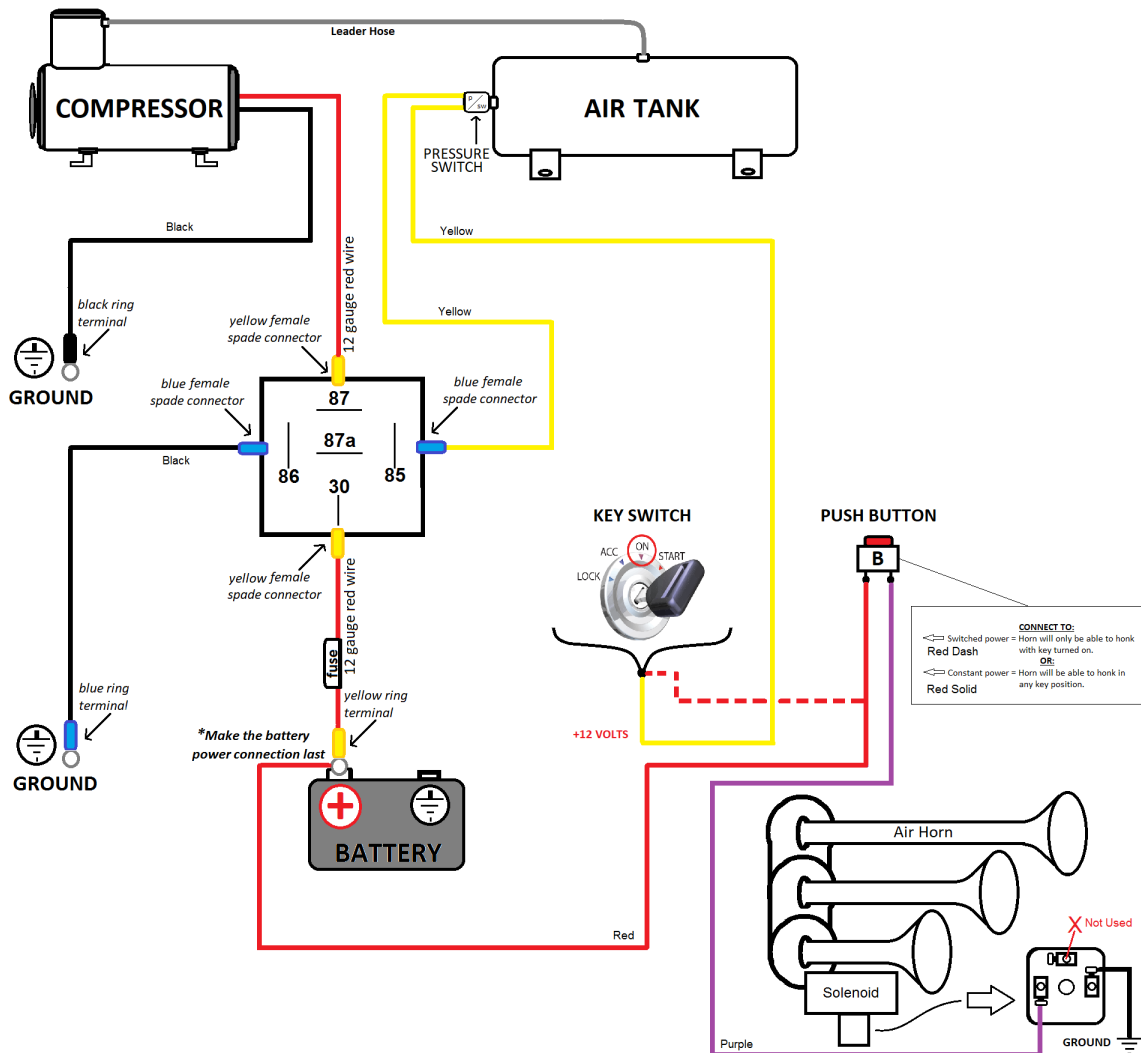

Figure 12- Wiring Diagram

9. On-Vehicle Assembly

1. With the spare tire cable lowered, insert the metal flange into the center hole of the USTL. Position the flange in any orientation that does not interfere with the components.



Figure 13- USTL On-Vehicle Install #1

2. Raise the USTL into position and guide it into place, until the arms rest on the crossbars.

NOTE: The USTL will be off balance when hoisted up. Be sure to keep it level, or at a slight angle when raising it into position until both arms are resting on the crossbar.

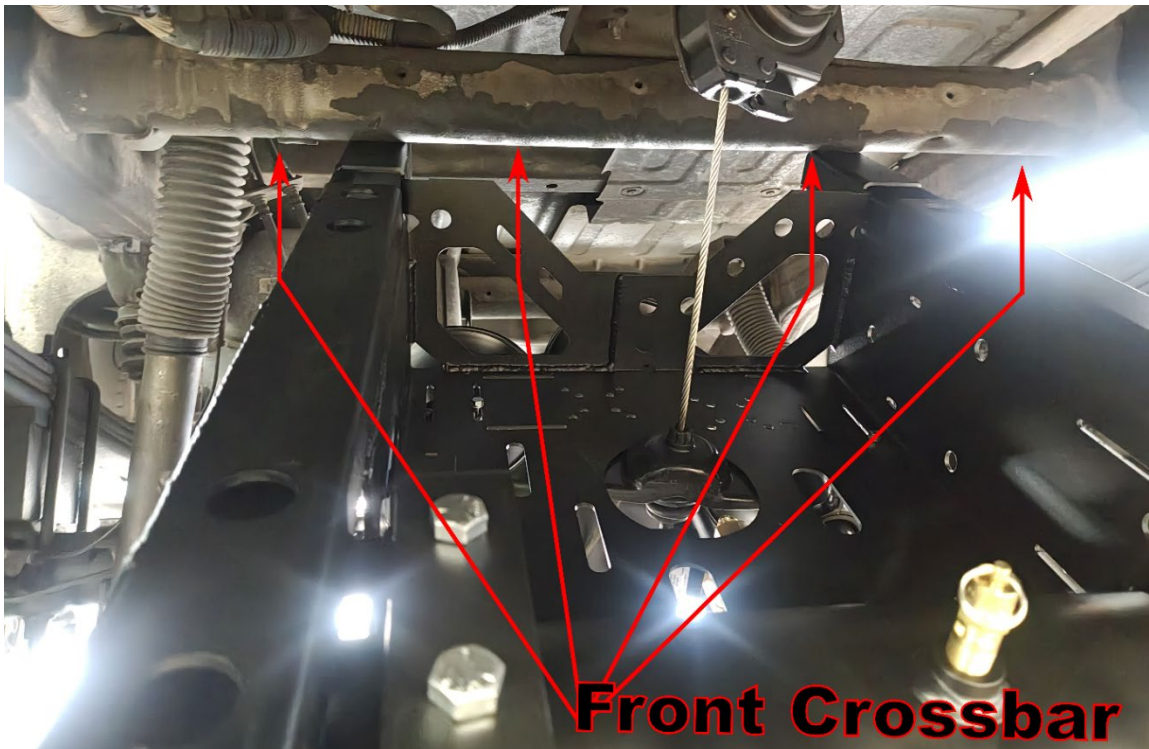

Figure 14- USTL On-Vehicle Install #2

3. Be sure the USTL is fully secured by the winch tension.
4. Complete the installation by installing the 1301 (if desired) & the 1302. Plumb them to the tank.
5. Finish final installation by completing electrical connections as desired.

10. Testing the Air System

It is recommended to check your wiring for shorts & continuity & double checking your connections prior to reconnecting the battery.

It is recommended to check the drain valve on the tank and ensure it is fully closed.

10.1. Air Compressor Test

1. Start the vehicle & allow the air compressor to run and fill up the tank.

NOTE: The compressor should turn off after tank reaches ~ 150 PSI. This should take between 2-5 minutes. If the compressor runs excessively, a leak may be present in the system.

2. Allow the tank to drain via, the horns (if installed), the Inflator kit, or the tanks drain valve.
3. Wait for the compressor to start up again to replenish the air supply.
4. Wait for the compressor to turn off when tank is fully pressurized.

10.2. Quick Connect Coupler Test

The quick connect coupler can be used to run the included INF-1 tire inflator kit or certain air tools.

1. If needed, allow the air compressor to refill the air tank.
2. Attach the INF-1 inflator kit and inflate tires
3. Optionally, an air blow gun/nozzle or an air nailer can be used to test the quick connect coupling.

11. Maintenance

!!WARNING!! Operating the air compressor above it maximum pressure rating may damage the internal components and/or cause unsafe system conditions. It is recommended not to exceed 150 PSI pressure in the system.!!

This air compressor is equipped with automatic thermal overload protection. If thermal overload is triggered, the safety circuit will reset after 30 minutes.

This air compressor is oil-less, never lubricate or add liquids to this compressor.

Monthly or every 10 Hours of Compressor Use:

- Drain the moisture from the air tank via the tanks drain valve.

Yearly or 12,000 Miles

- Replace the compressors air filter element. – Replacement frequency depends on operating & environmental conditions.
- Remove road grime or mud from components & brackets.
- Inspect all mounting fasteners to ensure they remain secure. Tighten as needed.
- Inspect electrical connections & loom for damage. Repair/Replace as needed.

12. Warranty Information

Thank you for purchasing this Air System. If you experience any unexpected problems during installation, or part failure at any time, please contact KLEINN Support.

KLEINN MANUFACTURER LIMITED DEFECT WARRANTY:

Kleinn Automotive Accessories warrants this product to the end-user, when properly installed and under normal conditions of use, to be free from defects in workmanship and materials for a period of one year from the provided date of purchase to the original purchaser of the product. This warranty does not cover abuse, operation in a manner inconsistent with the product's design, or damage resulting from exposure to the elements. If the defect is considered "under warranty", Kleinn will, at its option, repair or replace the product free of charge to the original purchaser. Kleinn is not liable for any installation charges, loss or damage of any kind incurred in the replacement or repair of any warranted product.

© Kleinn Automotive Accessories, All rights reserved.

Phone: [\(520\) 579-1531](tel:5205791531)

Web: www.Kleinn.com



Install Guide

Record of Revisions

USTL-OBA

Revision	Description	Date	Approval
A	Initial Revision	5/5/2026	AG