

Toyota (Push to Start)										
Tacoma			16	17	18	19	20	21	22	23
Tundra							20	21		
4 Runner							20	21		
C-HR					18	19	20	21	22	
Highlander	14	15	16	17	18	19				
Highlander Hybrid	14	15	16	17	18	19				
Sequoia							20	21	22	
Land Cruiser			16	17	18					

-This remote start will monitor the vehicle lock circuit and use the pulses generated by pressing lock 3 times on your OEM remote to start the vehicle.

-This is a pre-wired kit. The ECU and Steering Lock connections are plug-in connections required for all covered vehicles.

-Installation in 2016-2019 Tacoma, 2018-2019 C-HR, 2014-2019 Highlander (Gas and Hybrid) and 2016-2018 Land Cruiser is plug and play.

-The 2020 Tacoma, 2020 Tundra, 2020-2021 4 Runner, 2020-2022 C-HR and 2020-2022 Sequoia each require two wire connections that will be detailed later in this guide.

-We have already loaded the correct software into the remote start module. You will need to pair the module to the vehicle when the installation is complete.

Where Everything Goes

Remote Start Module – the wiring for the module is done under the dash on the driver’s side, so you’ll want to install the module in that general area. Before you start wiring, look for a location where there’s some open space that will fit the module. Pay attention to moving parts like the pedals, e-brake and steering column. Be sure to route your wiring away from those areas.

- Set the parking brake and without pressing the foot brake press the push to start button twice to turn the ignition on.
- Turn the steering wheel to the right to access a screw and remove the screw.
- Turn the steering wheel to the left to access the screw on the other side and remove the screw.
Use a plastic pry tool to separate the top and bottom half of the steering column cover.
- Pull the bottom cover down to separate the two halves.
- Turn the ignition off by pressing the push to start button one time. The steering lock connector is now accessible at underside of the steering column.
- Remove the side dash panel and lower dash panel. It should be held on by a few clips.
- Once the side panel is off make sure there are not any screws holding the lower dash panel on. Most vehicles do not have any screws - the front lower dash is secured by plastic clips. Gently pull the lower plastic panel and it will come unclipped.
- You will now see the ECU on the left side of the dash.

Connecting The T-Harness

1. Steering Lock plug

Locate the Steering Lock Connector on the underside of the steering column. Remove the OEM plug from the vehicle and replace it with the plug on the T-harness. Insert the OEM plug in to the female receptacle on the T-harness.

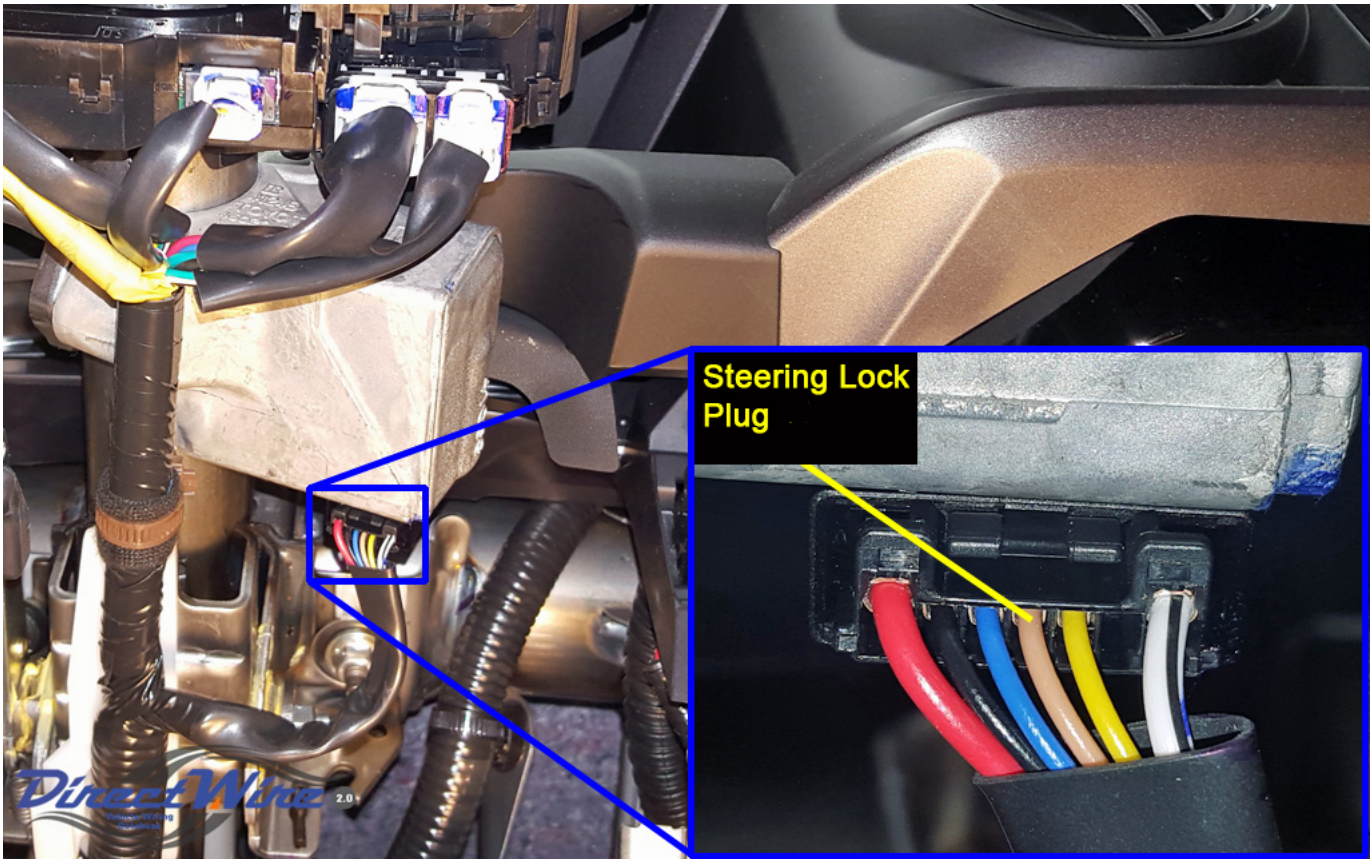

2. ECU plug

The main body ECU is behind the dash on the left side. Locate the 30 pin plug on the ECU and unplug it from the ECU. Insert the male connector from the T-harness in to the vacated center position on the ECU. Insert the OEM plug in to the female receptacle on the T-harness.

- 2016-2019 Tacoma, 2018-2019 C-HR, 2020-2022 Sequoia, 2014-2019 Highlander and 2016-2018 Land Cruiser are plug & play. You can proceed to the programming steps on page 10.

- For 2020 Tacoma, 2020 Tundra, 2020-2021 4 Runner, 2020-2022 C-HR and 2020-2022 Sequoia You will need to make the telematics connections shown later in this guide on pages 5-10.



System Wiring Overview -

2016-2019 Tacoma, 2018-2019 C-HR, 2020-2022 Sequoia,
2014-2019 Highlander (Gas and Hybrid) and 2016-2018 Land Cruiser

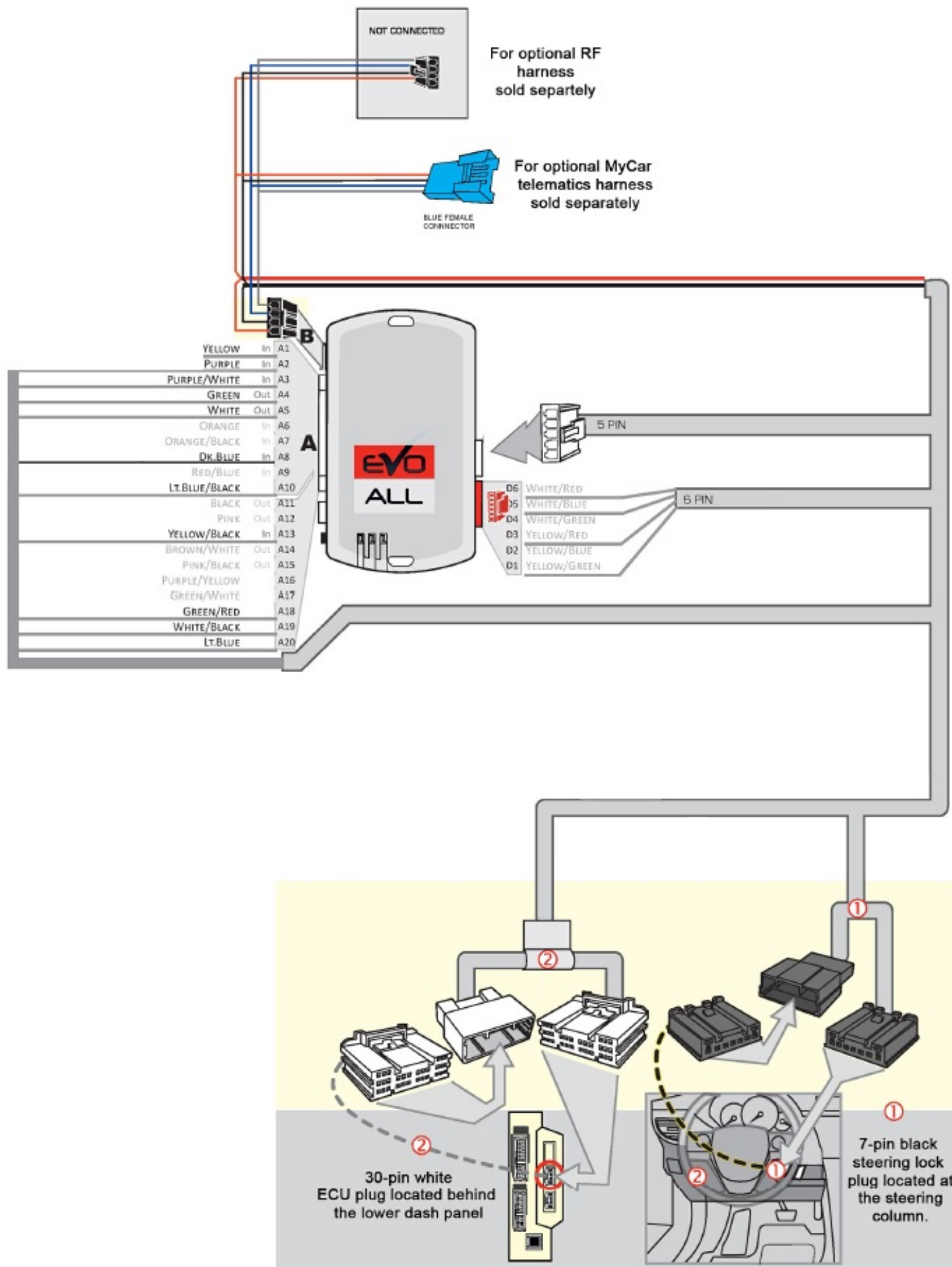

2020 Tacoma ONLY - Additional Connections

1. Locate the Red 6-pin plug in the remote start T-Harness. Cut the Yellow/Red AND the Yellow/Green wires about half way between the red plug and where the wires enter the loom.

2. Join the two 'halves' of the wires that go in to the T-Harness loom together.

3. Extend each of the wires on the plug side separately with enough wire to reach the far side of the glove box. Route the wires behind the center console and to the glove box area.

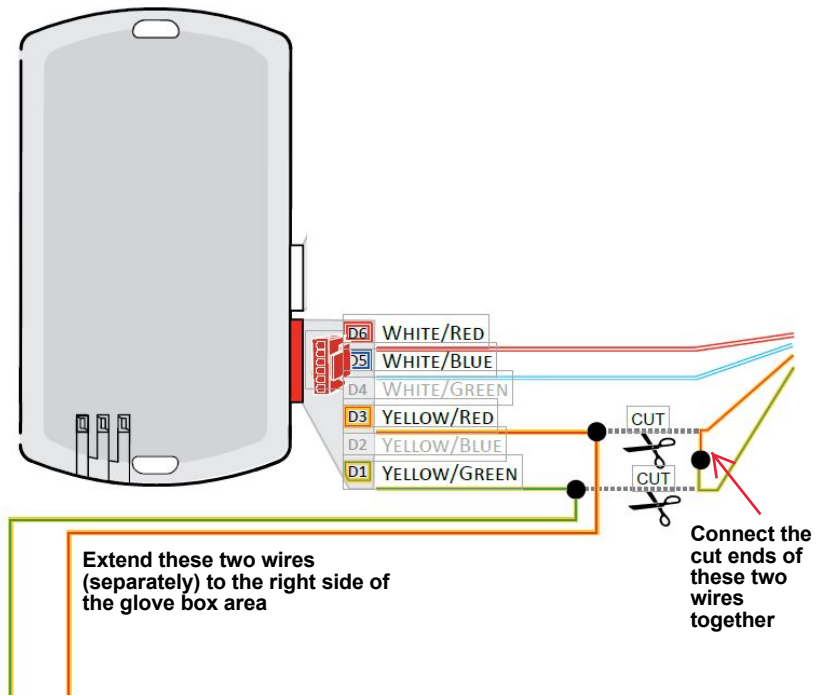

4. Now remove the glove box and locate the Telematics Module as shown here.

There is a Blue wire in pin position 1 on the Telematics plug. That wire needs to be cut. You will need to connect wires on to both sides of the cut, so locate your cut with as much slack wire as possible on both sides.

5. Butt connect or solder the extension of the Yellow/Red wire to the side of the Blue wire that goes to the Telematics plug.

6. Butt connect or solder the extension of the Yellow/Green wire to the side of the Blue wire that goes into the vehicle wiring.

7. Proceed to programming. See Page 15.

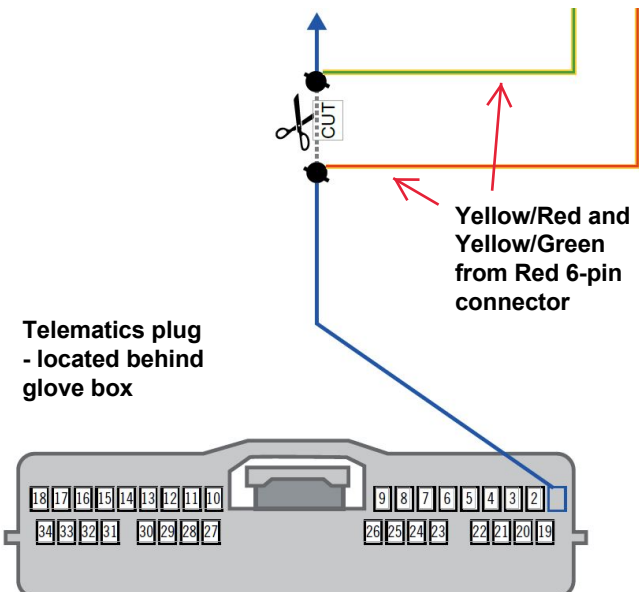
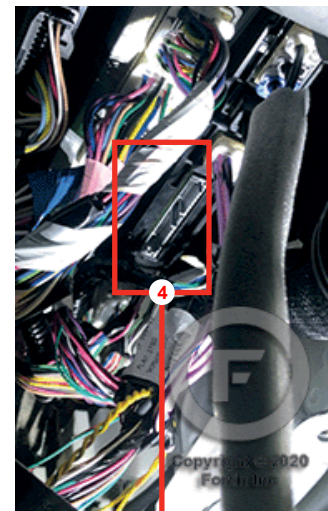

2020 Tundra ONLY - Additional Connections

1. Locate the Red 6-pin plug in the remote start T-Harness. Cut the Yellow/Red AND the Yellow/Green wires about half way between the red plug and where the wires enter the loom.

2. Join the two 'halves' of the wires that go in to the T-Harness loom together.

3. Extend each of the wires on the plug side separately with enough wire to reach the dash fuse box. Route the wires dash fuse box area.

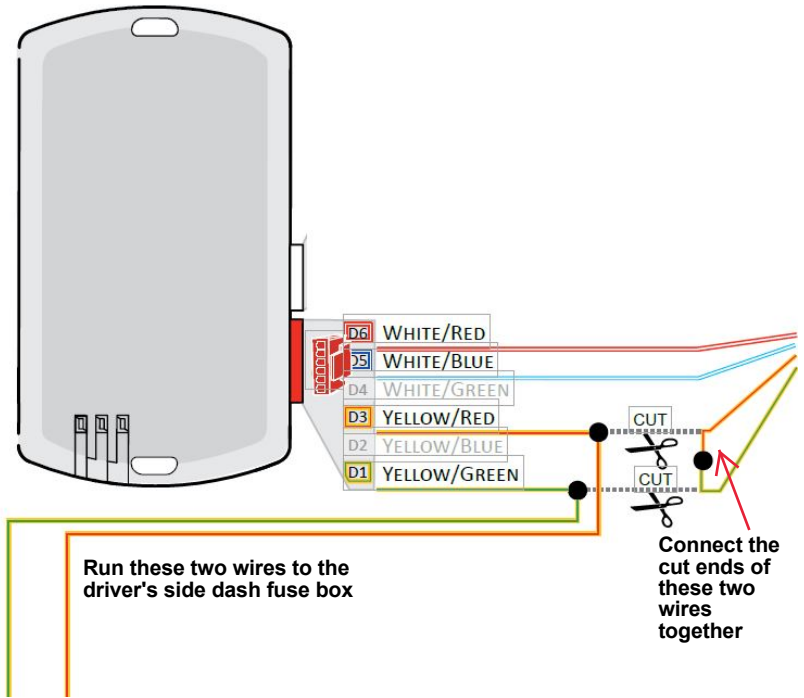

4. Locate the driver's side fuse box under the left side of the dash and the white 56-pin plug shown here.

5. There is a Red wire in pin position 33. That wire needs to be cut. You will need to connect wires on to both sides of the cut, so locate your cut with as much slack wire as possible on both sides.

6. Butt connect or solder the Yellow/Red wire to the side of the Red wire that goes to the Telematics plug.

7. Butt connect or solder the Yellow/Green wire to the side of the Red wire that goes into the vehicle wiring.

Proceed to programming. See Page 15.

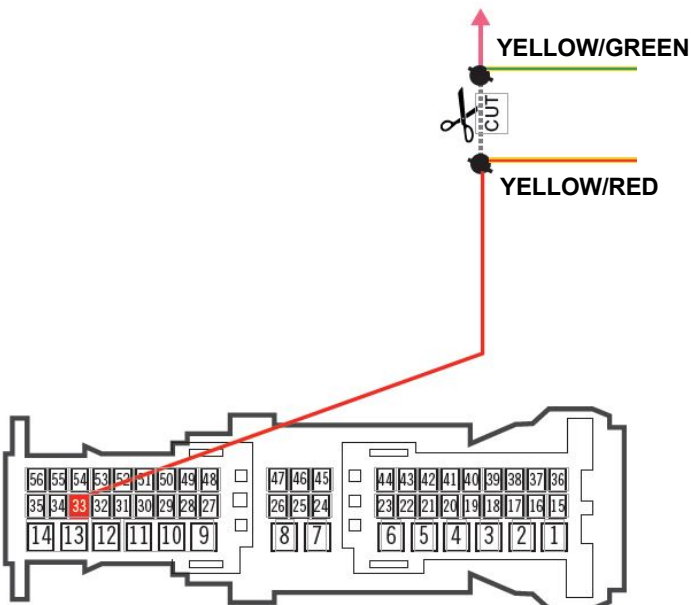
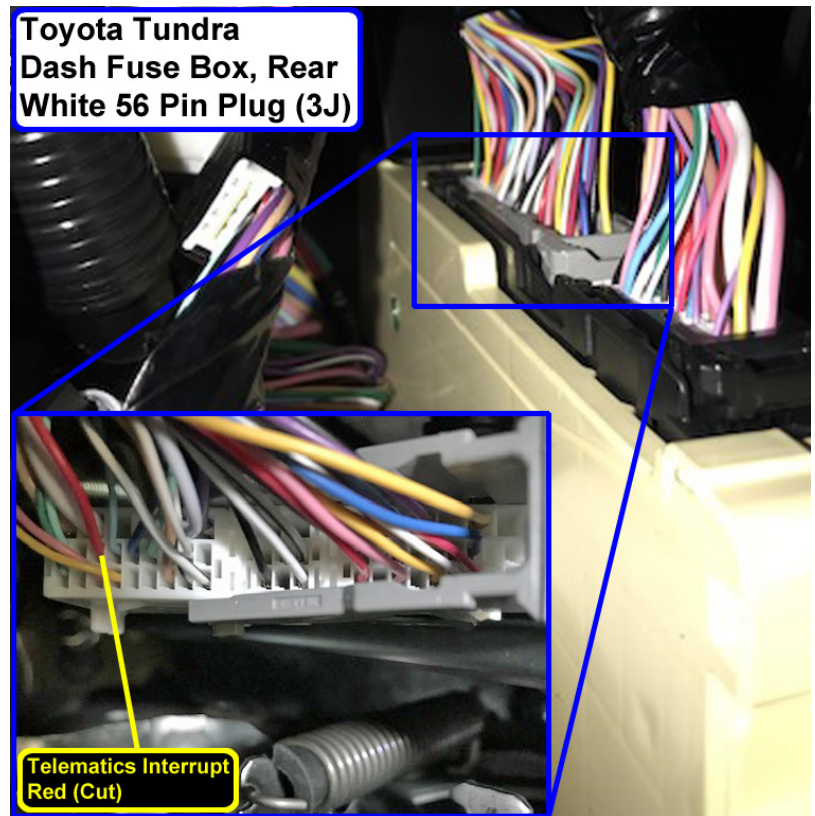

2020-2021 4 Runner ONLY - Additional Connections

1. Locate the Red 6-pin plug in the remote start T-Harness. Cut the Yellow/Red AND the Yellow/Green wires about half way between the red plug and where the wires enter the loom.

2. Join the two 'halves' of the wires that go in to the T-Harness loom together.

3. Extend each of the wires on the plug side separately with enough wire to reach the dash fuse box. Route the wires dash fuse box area.

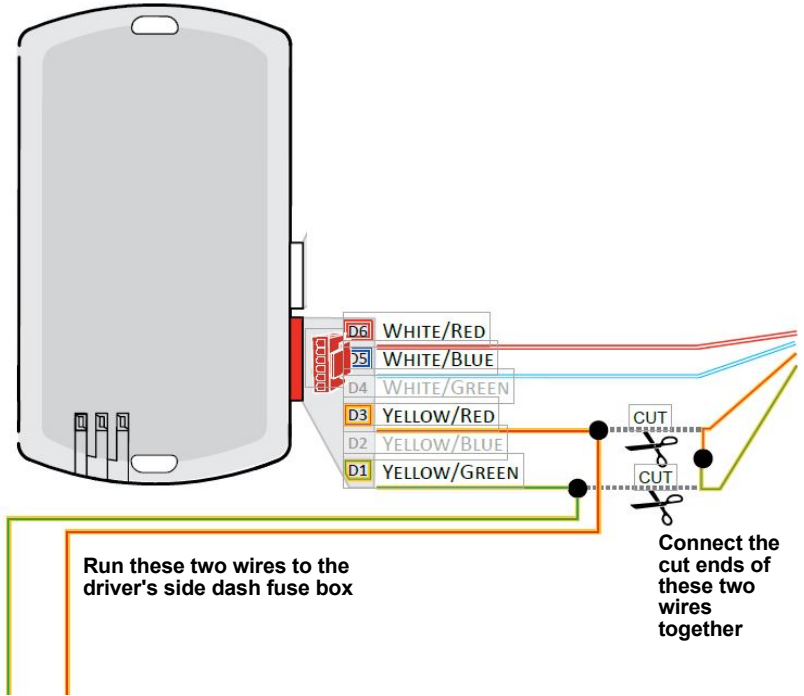

4. Locate the driver's side fuse box under the left side of the dash and the white 56-pin plug shown here.

5. There is a Pink wire in pin position 19. That wire needs to be cut. You will need to connect wires on to both sides of the cut, so locate your cut with as much slack wire as possible on both sides.

6. Butt connect or solder the Yellow/Red wire to the side of the Pink wire that goes to the Telematics plug.

7. Butt connect or solder the Yellow/Green wire to the side of the Pink wire that goes into the vehicle wiring.

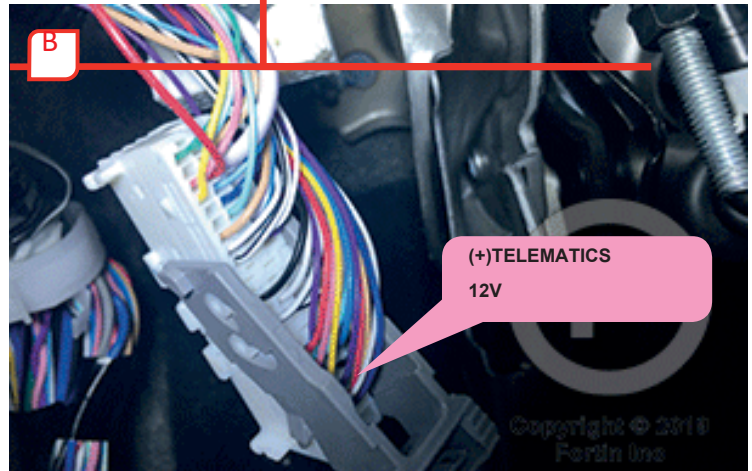
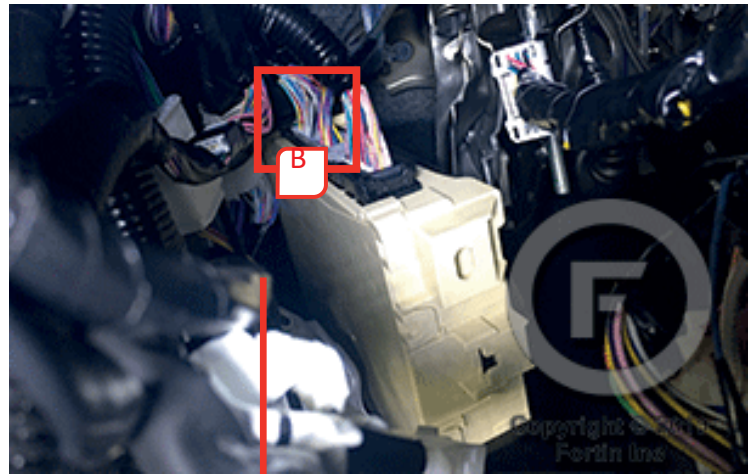

Proceed to programming. See Page 15.

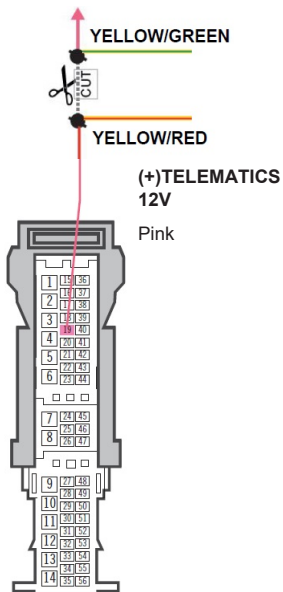

2020 -2022 C-HR ONLY - Additional Connections

1. Locate the Red 6-pin plug in the remote start T-Harness. Cut the Yellow/Red AND the Yellow/Green wires about half way between the red plug and where the wires enter the loom.

2. Join the two 'halves' of the wires that go in to the T-Harness loom together.

3. Extend each of the wires on the plug side separately with enough wire to reach the passenger kick panel. Route the wires behind the center console and to the passenger kick panel.

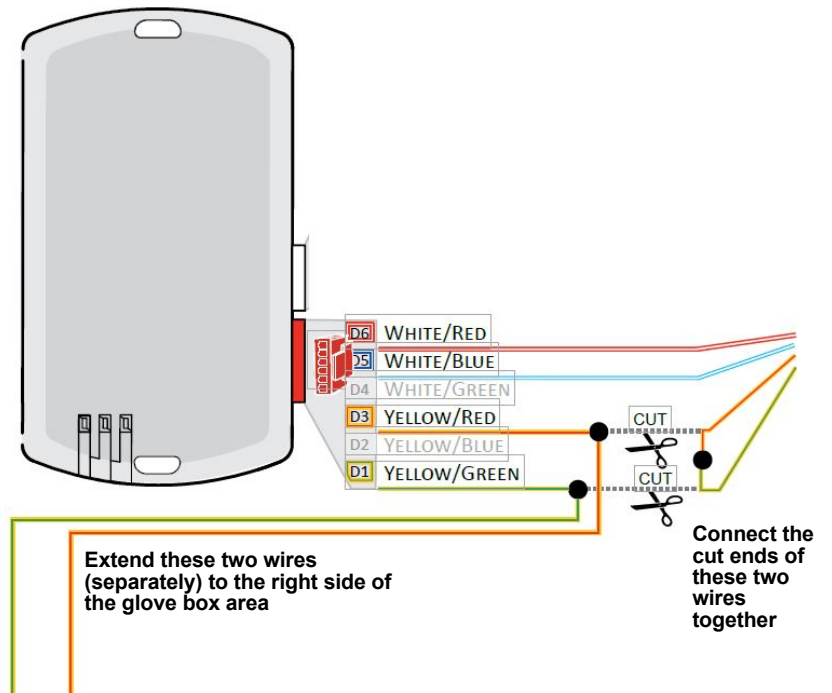

4. Now remove the passenger kick panel and locate the Telematics Module as shown here.

There is a Tan wire in pin position 6 on the Telematics plug. That wire needs to be cut. You will need to connect wires on to both sides of the cut, so locate your cut with as much slack wire as possible on both sides.

5. Butt connect or solder the extension of the Yellow/Red wire to the side of the Tan wire that goes to the Telematics plug.

6. Butt connect or solder the extension of the Yellow/Green wire to the side of the Tan wire that goes into the vehicle wiring.

7. Proceed to programming. See Page 15.

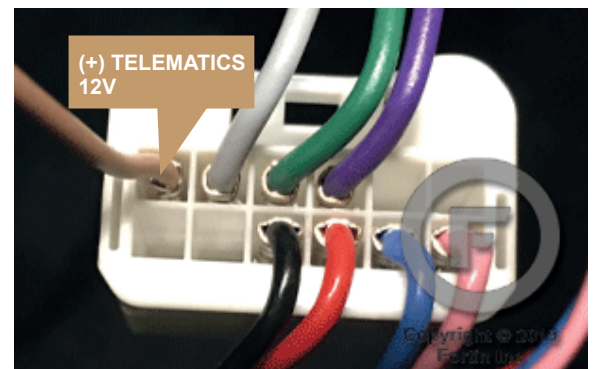
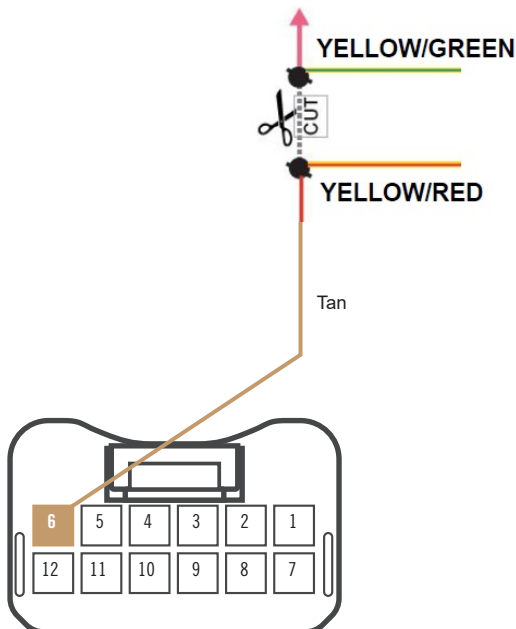

2020-2022 Sequoia ONLY - Additional Connections

1. Locate the Red 6-pin plug in the remote start T-Harness. Cut the Yellow/Red AND the Yellow/Green wires about half way between the red plug and where the wires enter the loom.

2. Join the two 'halves' of the wires that go in to the T-Harness loom together.

3. Extend each of the wires on the plug side separately with enough wire to reach the rear of the dash fuse box. Route the wires to the rear of the dash fuse box.

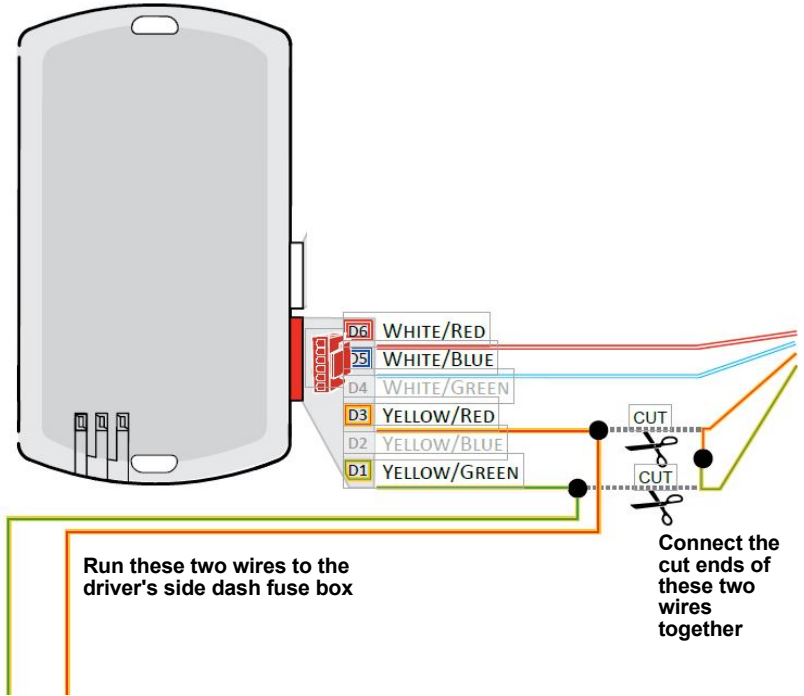

4. Locate the driver's side fuse box under the left side of the dash and the white 56-pin plug shown here.

5. There is a Violet wire in pin position 33. That wire needs to be cut. You will need to connect wires on to both sides of the cut, so locate your cut with as much slack wire as possible on both sides.

6. Butt connect or solder the Yellow/Red wire to the side of the Violet wire that goes to the Telematics plug.

7. Butt connect or solder the Yellow/Green wire to the side of the Purple wire that goes into the vehicle wiring.

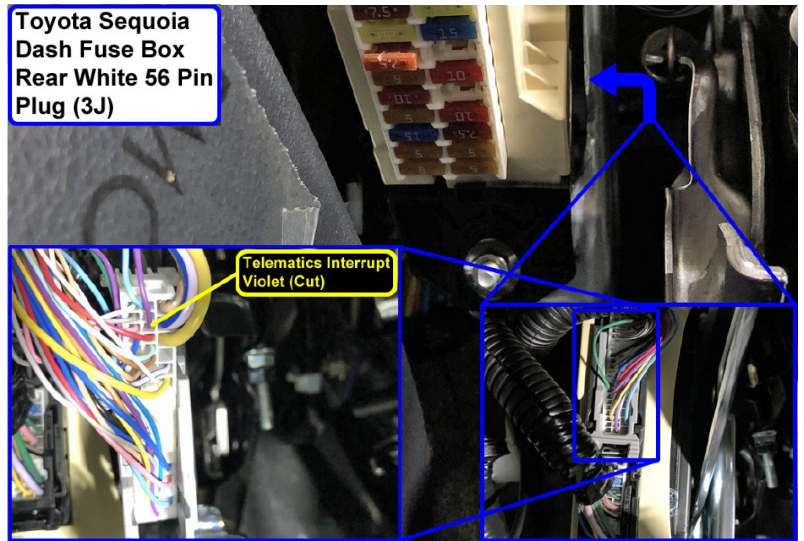

Proceed to programming. See Page 15.

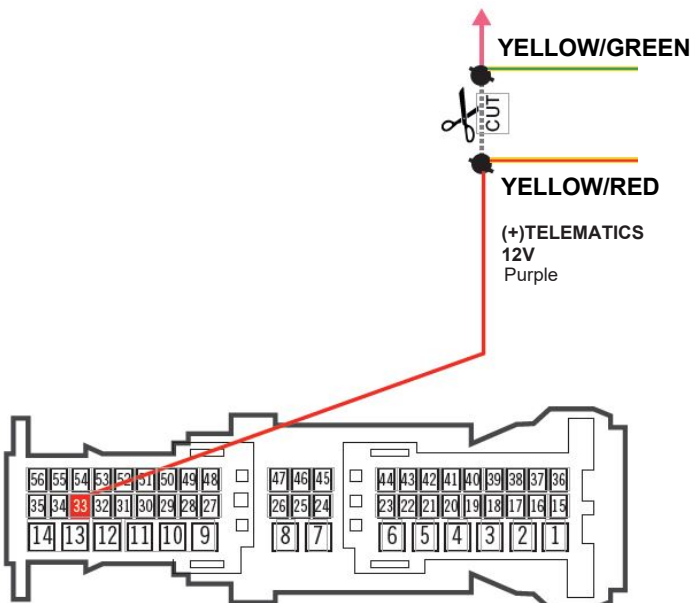

Programming and Operation

The last step of the installation process is pairing the remote start module to the vehicle. Start by disconnecting all the plugs from the remote start.

1

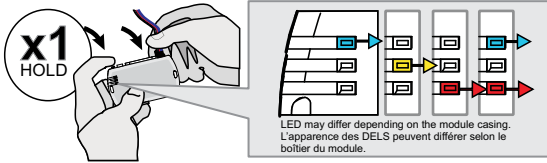

Press and hold the programming button:
Connect the 4-PIN Data-link harness (Black connector).

↳ The Blue, Red, Yellow and Blue & Red LEDs will alternatively illuminate.

2

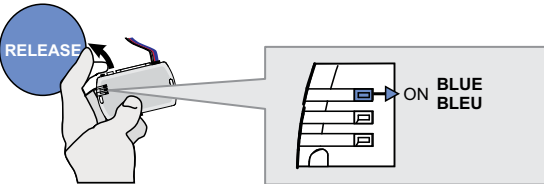

Release the programming button when the LED is BLUE.

If the LED is not solid BLUE disconnect the 4-Pin connector (Data-Link) and go back to step 1.

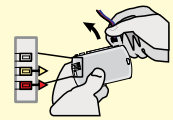

3

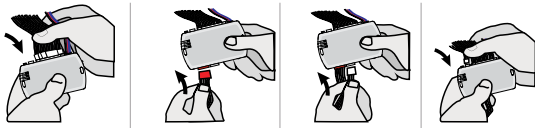

Insert the required remaining connectors.

4

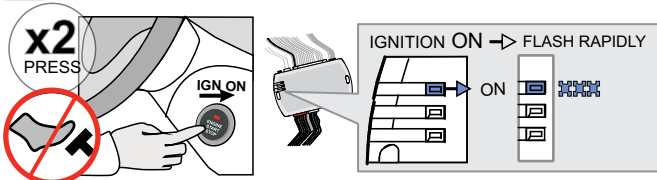

Do not press the brake pedal.
Press the Push-to-Start button twice to turn on the ignition.

↳ Wait for the BLUE LED will flash rapidly and constantly.

5

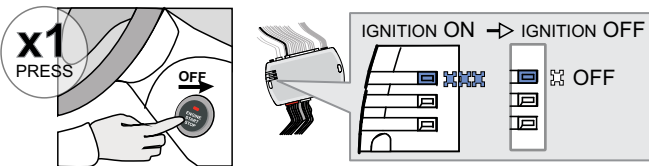

Press the Push-to-Start button once to turn off the ignition.

↳ The BLUE LED will turn off. **Programming is complete**

<p>All doors must be closed.</p>	<p>Remote start the vehicle.</p>	<p>Unlock the doors with the OEM remote</p>	<p>The module will shut down the vehicle as soon as the drivers door is opened.</p>	<p>Enter the vehicle with the Smart-Key.</p>	<p>Press the vehicle with the Smart-Key.</p>	<p>Press the Push-to-Start button to start the vehicle.</p>	<p>The vehicle can now be put in to gear and driven.</p>
----------------------------------	---	--	---	---	---	--	--

Technical Support and Troubleshooting

Issue: When attempting top program, the red LED turns on and nothing else happens

Solution: Do a master reset of the remote start module.

- Unplug the remote start module completely.
- Hold the button down and plug in the 4-pin plug. The LED lights will cycle colors.
- Let go on RED. You will not need to plug anything in.
- Press and hold the button down. The LED lights will start to alternate colors.
- Let go of the button and unplug the EVO.
- Reset complete.

Issue: The plugs in the vehicle do not match the plugs in the installation harness.

Solution #1: Make sure the vehicle has the push-to-start ignition. This kit does not work in vehicles with key-start ignition.

Solution #2: A common mistake is using the incorrect plug at the main ECU. The correct plug is the one in the middle position.

Issue: The truck shuts down as soon as a door is opened.

Solution: This is normal operation. Because Toyota push-to-start trucks can be driven without a key present after they've been started, this is an important security feature.

Issue: Remote start does not activate, blue LED on remote start module flashes 3 times

Solution: 3 blue flashes indicates a problem with the connection at the telematics module (does not apply to 2016-19 Tacoma). Make sure the appropriate wire at the telematics module has been cut and the connections from both side of the wire to the Yellow/Red and the Yellow/Green wires is solid.

Should you need installation or troubleshooting assistance, contact Kleinn Technical Support at (520) 579-1531.