



---

# RZR1000-OBA INSTALLATION MANUAL

REV: A (12/3/2018)

---



© Kleinn Air Horns 2018, All rights reserved.  
PO Box 91278 Tucson, AZ 85752  
Phone: (520) 579-1531  
Web: [www.Kleinn.com](http://www.Kleinn.com)



# RZR1000-OBA

## Installation and Operation Manual

**This digital PDF is interactive.**

**Please save ink and paper...**



**Open interactive manual using Adobe Reader<sup>®</sup>**

**on [PC, MAC, and all smart devices](#)**



# RZR1000-OBA Installation and Operation Manual

## Table of Contents

- 1. LIST OF FIGURES .....5
- 2. How to Use this Manual .....6
  - 2.1. Interactive Manual using Adobe Reader.....6
  - 2.2. Your Kit Part Number and this Manual .....6
  - 2.3. Illustration/Photo Details and Orientation .....6
- 3. Safety First.....7
- 4. Application Chart.....8
  - 4.1. 100% Direct Bolt-On Vehicle List.....8
  - 4.2. \*\*Excluded Vehicles.....8
  - 4.3. Aftermarket Product Compatibility.....8
- 5. Kit Installation Overview .....9
  - 5.1. Approximate Installation Time..... 10
  - 5.2. \*\*\*Quick Install Outline..... 10
- 6. List of Tools and Supplies ..... 11
  - 6.1. Standard Tool List (Required)..... 11
  - 6.2. Special Tool List (Recommended) ..... 11
  - 6.3. Shop Consumables List (Recommended)..... 11
- 7. Parts List ..... 12
  - 7.1. Air Fittings and Related Items ..... 12
  - 7.2. Pre-Packaged Electro-Mechanical Items..... 13
  - 7.3. Electrical Small Components and Related Items ..... 13
  - 7.4. Bolt-On Mounting Brackets & Special Hardware..... 14
  - 7.5. Hardware/Fasteners ..... 15
- 8. On-Vehicle Electrical Installation..... 16
  - 8.1. Review suggested Wire Routing for Horn, Air Compressor, and Pressure Switch ..... 17
  - 8.2. Disconnect Vehicle Battery(s) ..... 17
  - 8.3. Attach Relay to Vehicle ..... 17
  - 8.4. Route Wiring ..... 18
  - 8.5. Connect Relay to Wiring..... 18
  - 8.6. Pressure Switch ..... 18
- 9. Bench Assembly Steps..... 19
  - 9.1. Assemble Fittings to Tank ..... 19



# RZR1000-OBA

## Installation and Operation Manual

9.1.4. Air Tank Exploded View with Fittings .....	19
9.2. Install Rubber Compressor Bushings & Bolts .....	20
10. On-Vehicle Mechanical Assembly Steps.....	22
10.1. Vehicle Preparation.....	22
10.2. Air Tank Brackets Installation.....	24
10.3. Air Compressor Bracket Installation .....	26
10.4. TURBO ONLY: Re-install Firewall Heat Shield.....	27
10.5. Air Tank Installation, Preliminary .....	27
10.6. Air Compressor Installation.....	30
10.7. Air Tank Installation, Final .....	31
10.8. Connect Air Compressor to Air Tank and Electrical .....	32
10.9. Connect Air Compressor to Inlet Filter .....	32
10.10. Re-Connect Air Intake and Drive-Belt Cooling Tube.....	32
11. Initial Testing of Kit.....	33
11.1. Reconnect Vehicle Battery(s) .....	33
11.2. Test Air Compressor .....	33
11.3. Test Quick Connect Coupler .....	33
12. General Operation of Kit .....	34
12.1. Compressor Operation.....	34
13. Routine Maintenance .....	34
14. Warranty Information .....	34



# RZR1000-OBA

## Installation and Operation Manual

### 1. LIST OF FIGURES

Figure 1 - Location/Layout of Air System on Vehicle .....	9
Figure 2 - Suggested Ignition Relay Diagram for Air Compressor and Air Tank .....	16
Figure 3 - Suggested Wire Routing for Horn, Air Compressor, and Pressure Switch .....	17
Figure 4 - Example of Relay and Fuse Mounted with Wire Loom .....	17
Figure 5 - Air Tank Exploded View .....	19
Figure 6 - Air Compressor with Bolts Installed as Studs .....	20
Figure 7 - Air Compressor Bracket with Rubber Grommets Installed .....	21
Figure 8 - Drive Belt Cooling Tubing, to Remove .....	22
Figure 9 - Air Intake Tubing, to Remove .....	23
Figure 10 - Firewall Heat Shield, to Remove (Turbo Only) .....	23
Figure 11 - Air Tank Brackets with Air Tank Bolts taped to bottom .....	24
Figure 12 - Driver Side Sway Bar Nuts/Bolts, to Remove .....	24
Figure 13 - Driver Side Air Tank Bracket Insertion.....	25
Figure 14 - Driver Side Sway Bar Nuts/Bolts with Air Tank Bracket Inserted.....	25
Figure 15 - Air Compressor Bracket Installed on Frame.....	26
Figure 16 - Air Compressor Assembly & Hardware Exploded View .....	27
Figure 17 - Air Tank and Air Tank Brackets Exploded View .....	28
Figure 18 - Air Tank to Vehicle Clearance.....	29
Figure 19 - Air Tank Installed with Pressure Switch Wired .....	29
Figure 20 - Air Compressor Installed to Bracket.....	30
Figure 21 - Driver Side Sway Bar Final Torque of Nuts/Bolts .....	31
Figure 22 - Access to Air Tank Feet Bolts through Firewall .....	31
Figure 23 - Air Compressor Final Install with Leader Hose Connection to Air Tank.....	32



# RZR1000-OBA

## Installation and Operation Manual

## 2. How to Use this Manual

### 2.1. Interactive Manual using Adobe Reader

It is recommended to open this digital PDF using Adobe Reader<sup>®</sup> to take advantage of following key features:

- **Hyperlinks** ([blue underlined text](#)) allow access to additional content via internet; click/tap to activate
  - Includes [Installation Figures](#) and “[Figure xx](#)”
- **Table of Contents** page allows easily navigating this manual; click/tap any section line to go to it
- **Bookmarks** allow quickly navigating to any section; click/tap
- **Zoom IN** on pictures by pressing “CTRL and +” at same time on PC, or pinch in on smart devices
- **Zoom OUT** on pictures by pressing “CTRL and -” at same time on PC, or pinch out on smart devices

---

### To install Adobe Reader<sup>®</sup>

On PC, or Mac

- visit <https://get.adobe.com/reader/otherversions/>

On Android, iPhone/iPad, and Windows devices,

- visit <https://acrobat.adobe.com/us/en/acrobat/mobile-app.html>
- 

### 2.2. Your Kit Part Number and this Manual

This manual covers installation, testing, and operation of following kit part numbers

#### 2.2.1. RZR1000-OBA (i.e., On-Board Air)

NOTE: Illustrations and pictures contained herein may represent only one kit part number. Where critical differences exist between kits (i.e., different parts, orientation, mounting points, etc.), additional text, or necessary graphics are provided to minimize confusion.

Parts list explicitly state kit differences with **(BOLD TEXT)** inside parenthesis, shown below part number.

### 2.3. Illustration/Photo Details and Orientation

This manual may use digitally created illustrations, and/or actual photos of example vehicle. These graphics may not include exact items found on your vehicle (i.e., electrical wiring, fuel lines, body panels, etc.). Illustrations typically will be missing details and are for clarity to show critical mounting locations and orientation on vehicle.

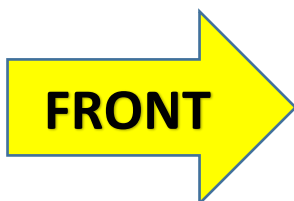

Throughout this manual yellow arrows with text reading “FRONT”, may be present over illustrations and pictures. These arrows specify direction toward front of vehicle and provide clarity to how illustration is viewed.



# RZR1000-OBA

## Installation and Operation Manual

### 3. Safety First

Read manual thoroughly before starting installation of this kit. Verify you have all parts listed and that you clearly understand this installation procedure. Contact Kleinn technical support for any questions.

Installation of this kit requires **moderate mechanical aptitude**; seek professional help if you're not competent using hand tools in tight uncomfortable spaces, and around possibly rusted and sharp vehicle parts.

Before starting, obtain proper tools required to perform installation correctly, adequate lighting, eye protection, hearing protection for operating train horns, and hand protection to guard against sharp edges and metal burrs, which may be present on kit parts and vehicle parts.

Throughout this manual the following words may be used; be aware of their meaning and application.

**CAUTION:** means damage could occur to vehicle, or kit parts during, or after installation

**WARNING:** means injury could occur to you or others, including damage to vehicle, or kit parts

**DANGER:** means serious injury or death could occur to you or others during installation



# RZR1000-OBA

## Installation and Operation Manual

### 4. Application Chart

#### 4.1. 100% Direct Bolt-On Vehicle List

RZR1000-OBA is a 100% direct bolt-on aftermarket product for POLARIS vehicles listed in below chart; every effort has been made to verify correct fitment on these vehicles in their factory, non-modified conditions.

MODEL YR	MODEL	DRIVE	ENGINE	BODY	TRIM
2014-2019	RZR 1000 XP	ALL	NON-TURBO	ALL	ALL **
2014-2019	RZR 1000 XP	ALL	TURBO	ALL	ALL **

NOTE: All vehicles listed may require drilling holes for ground wires and installing switches, based on preference of installed switch locations and wire grounding points.

#### 4.2. \*\*Excluded Vehicles

**RZR1000-OBA may NOT be compatible with following POLARIS vehicles:**

- 4.2.1. All trim packages with upgraded rear body panels (i.e., rock protection, aggressive flairs, etc.)
- 4.2.2. All trim packages with self-adjusting/automatic suspension, such as Polaris DYNAMIX
- 4.2.3. All trim packages with high-flow air intakes/clutch cooling, or snorkel style tubing
  - 4.2.3.1. Vehicles with these OEM upgrades may require body, chassis, or kit modifications to properly install
  - 4.2.3.2. Review this manual in full before unpackaging kit and verify correct space and mounting locations exist with your trim package

#### 4.3. Aftermarket Product Compatibility

This kit has NOT been designed, or tested for use with aftermarket rear suspension trailing arms, sway bars, sway bar disconnects, exhaust systems, bolt-on turbo/super chargers, air intake systems, etc.





# RZR1000-OBA

## Installation and Operation Manual

### 5. Kit Installation Overview

RZR1000-OBA consists of following sub-systems, located on vehicle, as follows:

ITEM	DESCRIPTION	MOUNTING LOCATION	APPROX. INSTALL TIME
1	1 Gal. Air Tank	Directly behind rear firewall, mounted between chassis sway bar mounts	2+ Hours
2	6350RC Air Compressor	Directly behind rear firewall, on Pass. side, mounted to frame tubing	1-2 Hours

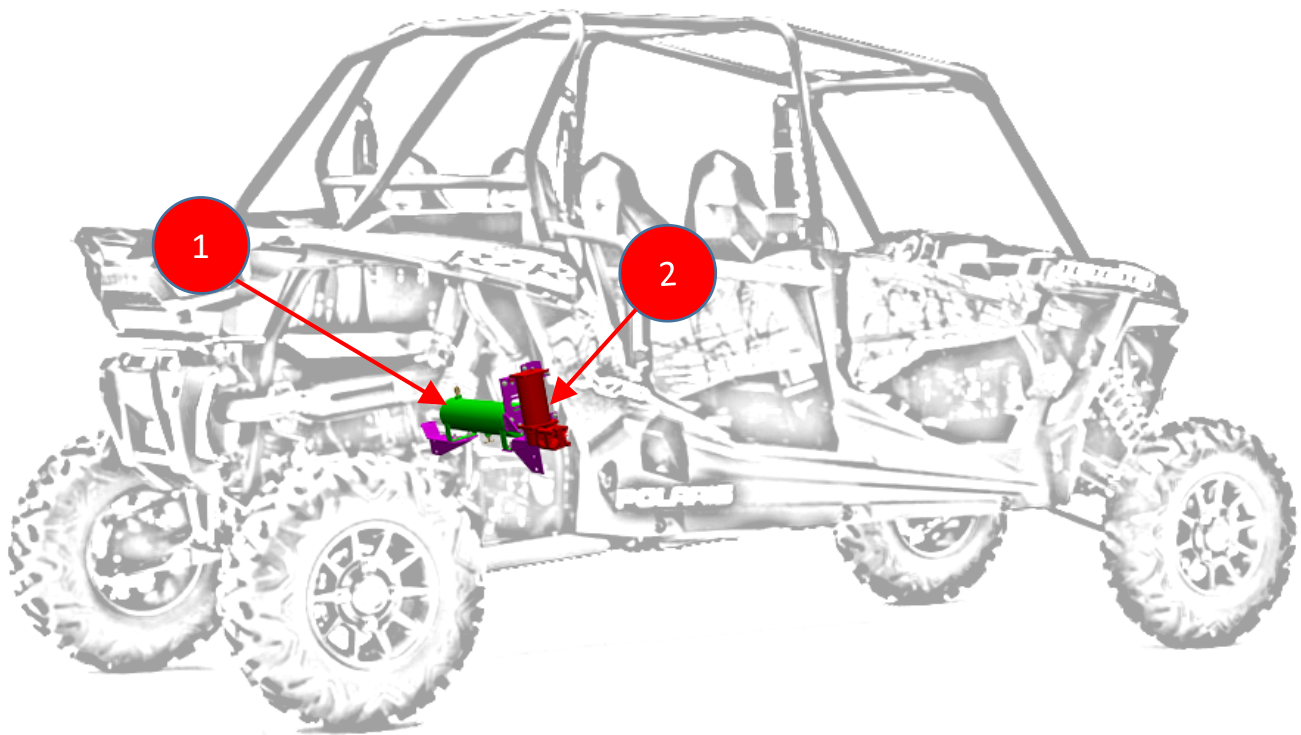

Figure 1 - Location/Layout of Air System on Vehicle



# RZR1000-OBA

## Installation and Operation Manual

### 5.1. Approximate Installation Time

RZR1000-OBA is a multi-faceted product consisting of multiple mechanical, electrical, and pneumatic components.

For a typical home mechanic, auto enthusiast, or technician installing a Kleinn Bolt-On kit for first time, a professional installation job with setup and testing of final product, is estimated to take:

- **3-6 Hours**
- 

### 5.2. \*\*\*Quick Install Outline

For person(s) with experience installing Kleinn bolt-on kits, RZR1000-OBA can be installed in an order similar to below:

1. Remove clutch cooling tube
2. Remove intake tube
3. Route and connect wiring
4. Remove firewall heat shield (TURBO ONLY)
5. Disconnect sway bar (one side at a time)
6. Attach air tank brackets into sway bar holes (one side at a time; leave nuts loose)
7. Attach compressor bracket to frame tube (leave nuts loose)
8. Reinstall firewall heat shield (TURBO ONLY)
9. Attach air tank (torque all bracket nuts & tank)
10. Attach compressor
11. Attach compressor hose to tank
12. Reinstall clutch & intake tubes
13. Test system



# RZR1000-OBA

## Installation and Operation Manual

### 6. List of Tools and Supplies

#### 6.1. Standard Tool List (Required)

- 6.1.1. Basic mechanic's 3/8" drive socket sets with extensions
  - Inch Size Sockets (1/4" – 1" Hex)
  - Metric Size Sockets (6mm – 20mm Hex)
- 6.1.2. Basic mechanic's 3/8" socket swivel/UV-Joint
- 6.1.3. Basic mechanic's combination wrenches (box/open-end) – Ratcheting preferred
  - Inch Size Wrenches (1/4" – 1" Hex)
  - Metric Size Wrenches (6mm – 20mm Hex)
- 6.1.4. Basic mechanic's hex wrench/hex driver set
  - 1. Metric Size Hexes (4mm-8mm)
- 6.1.5. Basic mechanic's screwdriver set (Philips, Flat Head)
- 6.1.6. Diagonal Cutter/Wire Cutter Pliers
- 6.1.7. Wire Strippers
- 6.1.8. Wire Terminal Crimpers
- 6.1.9. Slip-Joint Pliers
- 6.1.10. Utility Knife, or Utility Razor blade
- 6.1.11. Magnetic retrieval tool

#### 6.2. Special Tool List (Recommended)

- 6.2.1. 10-100 ft.-lb. torque wrench
- 6.2.2. 20-150 in.-lb. torque wrench
- 6.2.3. Multi-Meter for 12V DC electrical systems, or equivalent
- 6.2.4. 12V DC Test Light, or equivalent
- 6.2.5. Trim Panel Tool, for removing wiring push pins

#### 6.3. Shop Consumables List (Recommended)

- 6.3.1. Quality Electrical tape
- 6.3.2. Di-electric grease for electrical connections
- 6.3.3. Silicone grease, or equivalent for rubber compressor bushings
- 6.3.4. Heat Shrink tubing for electrical connections
- 6.3.5. Medium-Strength Loctite (i.e., Blue) (i.e., Loctite PN 242), or equivalent
- 6.3.6. Sand Paper, or Wire Brushes for installing ground wires
- 6.3.7. Extra plastic zip ties > 6" long
- 6.3.8. Extra NPT sealant (i.e., Kleinn Air Horn Juice, Teflon tape, etc.)
- 6.3.9. Touch-up paint for frame/chassis
- 6.3.10. Typical cleanup supplies



# RZR1000-OBA

## Installation and Operation Manual

### 7. Parts List

Below Parts List covers following kit part numbers:

RZR1000-OBA (i.e., On-Board Air)

Unpackage and organize Kit across a large work area and verify all parts are included, as listed below. Contact Kleinn support if any questions arise.

Review pre-packaged items (i.e., air compressor, air tank, etc.)

Review Air Fittings and Tubing

Review Wiring and Accessories

Review Bolt-On Mounting Brackets

Review Hardware/Fasteners



#### 7.1. Air Fittings and Related Items

ITEM	QTY	PART NUMBER	DESCRIPTION	PICTURE
1	1	2151 <a href="#">(view location on Air Tank)</a>	1/4" NPT Pressure Switch	
2	1	52835 <a href="#">(view location on Air Tank)</a>	1/4" NPT, Drain Valve	
3	1	52175 <a href="#">(view location on Air Tank)</a>	1/4" NPT, 175 PSI Safety Valve	
4	1	59813 <a href="#">(view location on Air Tank)</a>	1/4" NPT, Quick Connect Air Coupler, with Rubber Cover	



# RZR1000-OBA

## Installation and Operation Manual

5	1	6230RT	Air Tank, 4" OD, 1 Gal., 5-Port	
6	1	INF-1	Inflator Kit, with Air Hose and Bag	
7	1	KLEINN AIR HORN JUICE	Thread Sealant for NPT Fittings	



### 7.2. Pre-Packaged Electro-Mechanical Items

NOTE: Items in this section come in their own packages and may include additional items inside package

ITEM	QTY	PART NUMBER	DESCRIPTION	PICTURE
8	1	6350RC	6350RC Compressor Kit, with included hardware, and remote air supply line	

### 7.3. Electrical Small Components and Related Items

ITEM	QTY	PART NUMBER	DESCRIPTION	PICTURE
10	1	WIRE KIT	Full Wire Kit, with electrical connectors and zip ties	

11	1	¼" WIRE LOOM, 15 ft. Long	1/4" Wire loom for electrical routing	
12	1	1/8" WIRE LOOM, 15 ft. Long	1/8" wire loom for electrical routing	

### 7.4. Bolt-On Mounting Brackets & Special Hardware

ITEM	QTY	PART NUMBER	DESCRIPTION	PICTURE
13	1	RZR-101	COMPRESSOR BRACKET, INNER HALF	
14	2	RZR-102	SPACER, BRACKET HALF	
15	1	RZR-103	COMPRESSOR BRACKET, OUTER HALF	
16	1	RZR-201	TANK BRACKET, PASSENGER SIDE	
17	1	RZR-202	TANK BRACKET, DRIVER SIDE	



# RZR1000-OBA

## Installation and Operation Manual

### 7.5. Hardware/Fasteners

ITEM NO.	QTY.	HARDWARE SIZE	DESCRIPTION	WHERE USED
1	0	7/8" ID X 15/16"	CABLE CLAMP, VINYL COATED	RZR1000-KIT ONLY
2	2	5/16"-18 X 2.25"	SQUARE NECK BOLT, GRADE 2, ZINC-PLATED	COMPRESSOR MOUNT (2)
3	1	1/4"-20 X 1"	SQUARE NECK BOLT, GRADE 2, ZINC-PLATED	COMPRESSOR MOUNT (1)
4	4	1/4"-20 X .75"	SQUARE NECK BOLT, GRADE 2, ZINC-PLATED	COMPRESSOR MOUNT (4)
5	4	5/16"-18 X 1"	SQUARE NECK BOLT, GRADE 2, ZINC-PLATED	TANK MOUNT (4)
6	4	M5 X 0.8 X 30 LONG	HEX BOLT, GRADE 8.8, ZINC-PLATED	COMPRESSOR (4) – <i>INCLUDED IN COMPRESSOR BOX</i>
7	5	1/4" ID X 0.63 OD	FLAT WASHER, SAE, ZINC-PLATED	COMPRESSOR MOUNT (5)
8	6	5/16" ID X 0.69 OD	FLAT WASHER, SAE, ZINC-PLATED	COMPRESSOR MOUNT (2) TANK MOUNT (4)
9	4	M5 ID X 10 OD	FLAT WASHER, DIN, ZINC-PLATED	COMPRESSOR (4) - <i>INCLUDED IN COMPRESSOR BOX</i>
10	5	1/4"	LOCK WASHER, EXTERNAL TOOTH, ZINC-PLATED	COMPRESSOR MOUNT (5)
11	6	5/16"	LOCK WASHER, EXTERNAL TOOTH, ZINC-PLATED	COMPRESSOR MOUNT (2) TANK MOUNT (4)
12	4	M5	LOCK WASHER, STANDARD SPLIT, ZINC-PLATED	COMPRESSOR (4) - <i>INCLUDED IN COMPRESSOR BOX</i>
13	8	3/16" (#10)	FENDER WASHER, ZINC-PLATED	COMPRESSOR (8)
14	5	1/4"-20	HEX NUT, GRADE 2, ZINC-PLATED	COMPRESSOR MOUNT (5)
15	6	5/16"-18	HEX NUT, GRADE 2, ZINC-PLATED	COMPRESSOR MOUNT (2) TANK MOUNT (4)
16	4	M5 X 0.8	HEX NUT, GRADE 8.8, ZINC-PLATED	COMPRESSOR (4) - <i>INCLUDED IN COMPRESSOR BOX</i>

### 8. On-Vehicle Electrical Installation

**CAUTION:** Follow all recommended safety precautions for working on vehicle's electrical system; consult vehicle owner's manual for further instruction.

Review Suggested Wiring Diagram for Ignition Relay

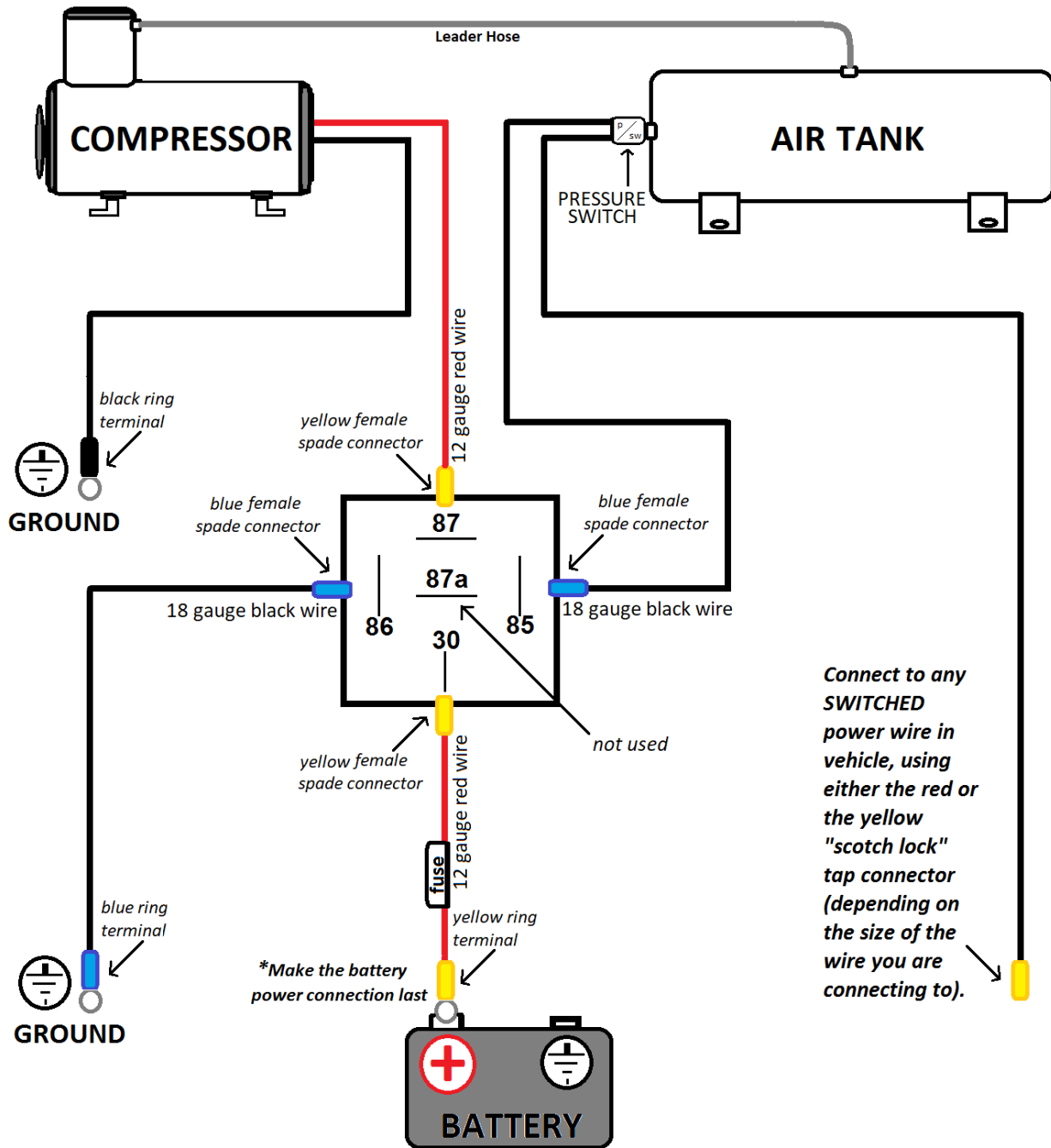

Figure 2 - Suggested Ignition Relay Diagram for Air Compressor and Air Tank



### 8.1. Review suggested Wire Routing for Horn, Air Compressor, and Pressure Switch

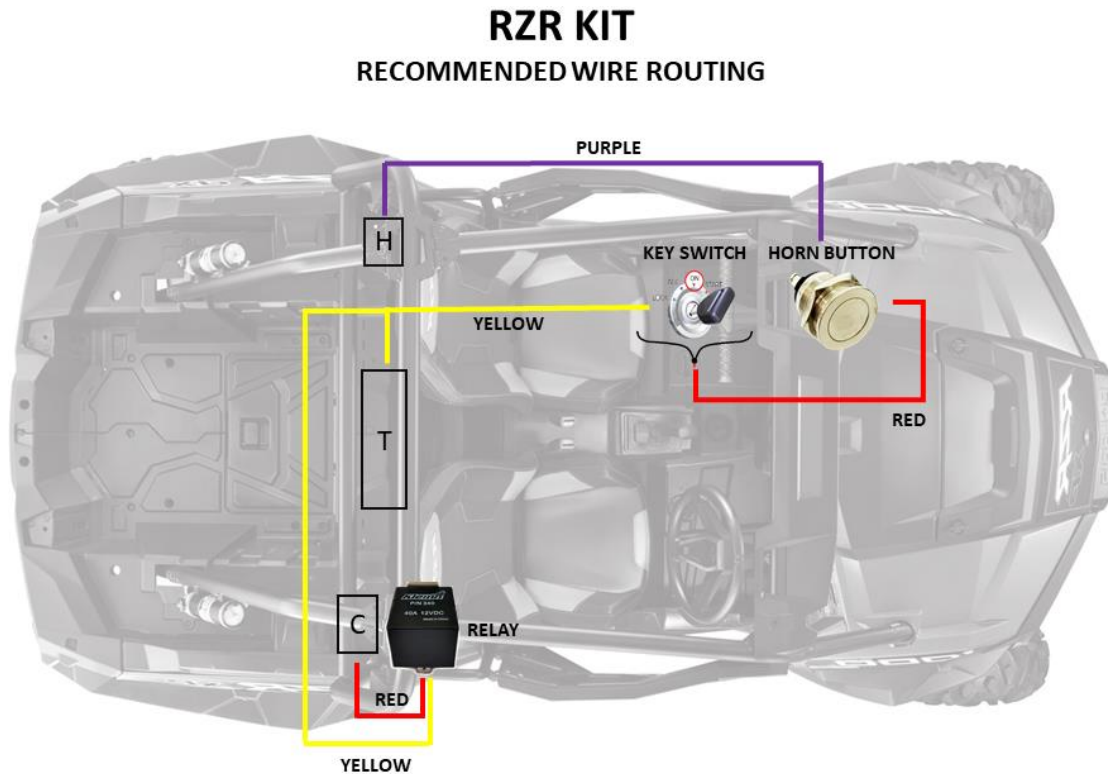

Figure 3 - Suggested Wire Routing for Horn, Air Compressor, and Pressure Switch

### 8.2. Disconnect Vehicle Battery(s)

### 8.3. Attach Relay to Vehicle

- 8.3.1. Fasten relay to vehicle body, under hood using supplied self-tapping screws. It is recommended to install in location near factory ground bolt, or battery(s) to minimize drilling holes.

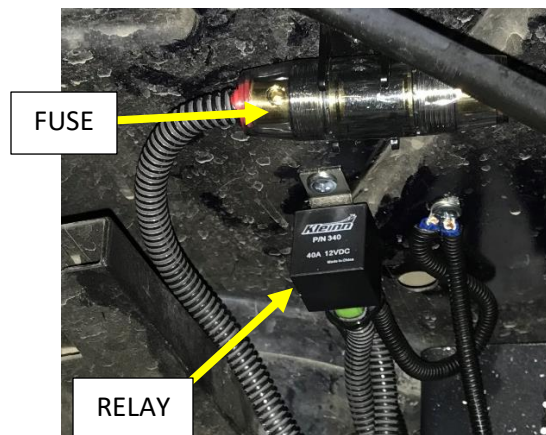

Figure 4 - Example of Relay and Fuse Mounted with Wire Loom



# RZR1000-OBA

## Installation and Operation Manual

### 8.4. Route Wiring

- 8.4.1. Route wiring throughout vehicle, per diagrams; however, installer may route as desired.
- 8.4.2. Insert all wiring into included wire loom and ensure loom is away from all sharp edges, hot vehicle parts (i.e., exhaust, engine, radiator), and fasten securely to vehicle using zip ties, or equivalent.

*NOTE: Do not cut wires to length until 100% sure of length required for final connections.*

- 8.4.3. Install supplied fuse holder on end of power wire by cutting the loop in fuse holder and connecting supplied Ring terminal to one end and Butt connector on other end.

**CAUTION:** *Do not install 30-amp fuse until all electrical connections are final.*

### 8.5. Connect Relay to Wiring

- 8.5.1. Connect routed wiring to relay, per wiring diagram.

### 8.6. Pressure Switch

- 8.6.1. Vehicle space constraints make it difficult to connect pressure switch in-vehicle; therefore, it is recommended to cut and connect a section of wiring to pressure switch during bench assembly, then perform final connection once Air Tank is installed in vehicle.

End of Section

### 9. Bench Assembly Steps

Complete following steps off vehicle to facilitate final installation.

NOTE: ALL HARDWARE WILL BE SPECIFIED IN INSTRUCTIONS USING ITEM NO.'S FOUND IN PARTS LIST. [See Parts List](#)

#### 9.1. Assemble Fittings to Tank

- 9.1.1. Apply two small drops of [Kleinn Air Horn Juice](#) to each male pipe thread.
- 9.1.2. Attach air fittings to tank, per illustrations.
- 9.1.3. Hand-tighten each fitting, then further tighten each 1/4-1/2 turn using proper sized box-end wrench; adjust as necessary to match fitting orientation shown.

#### 9.1.4. Air Tank Exploded View with Fittings

[Return to Fittings List](#)

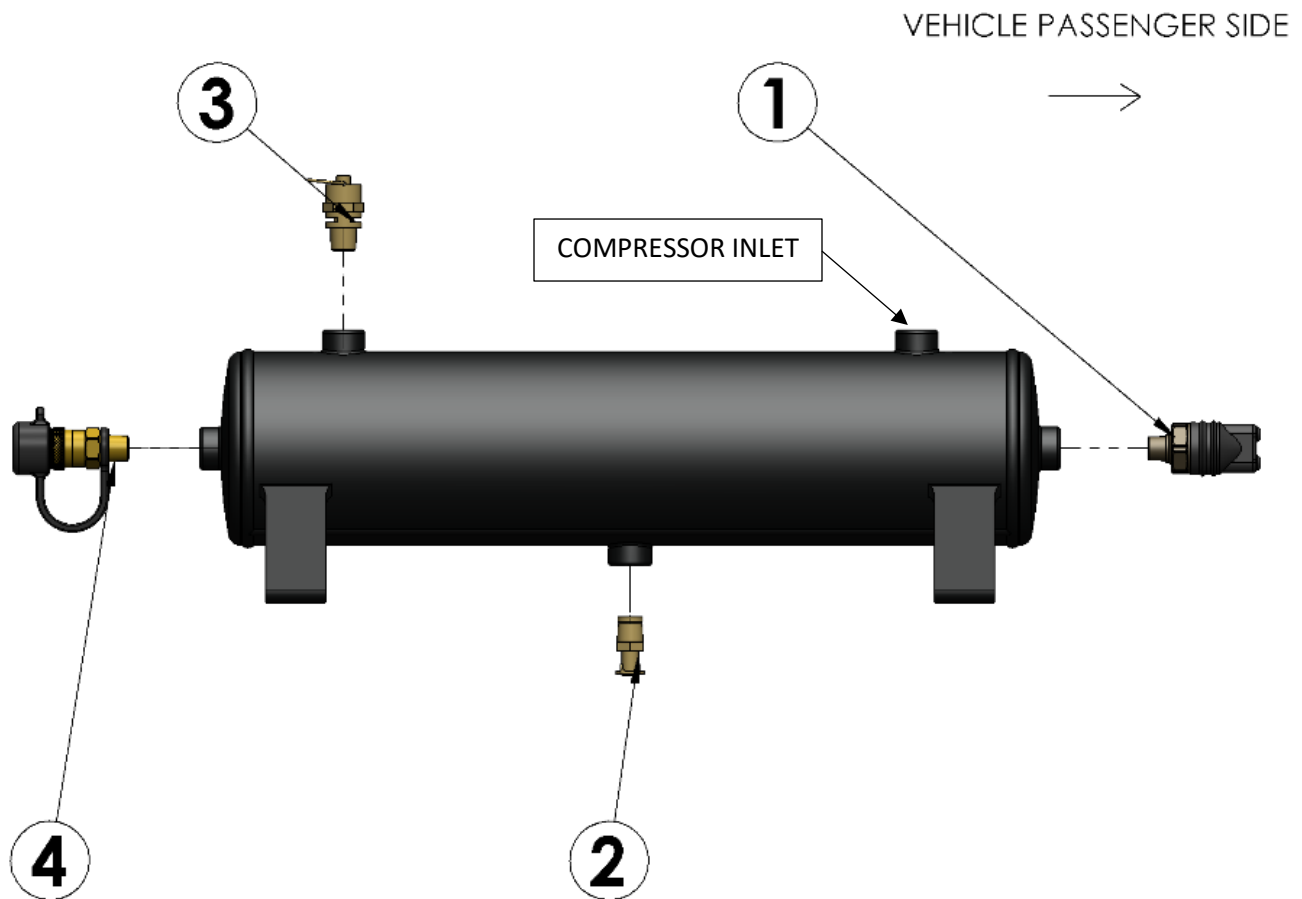
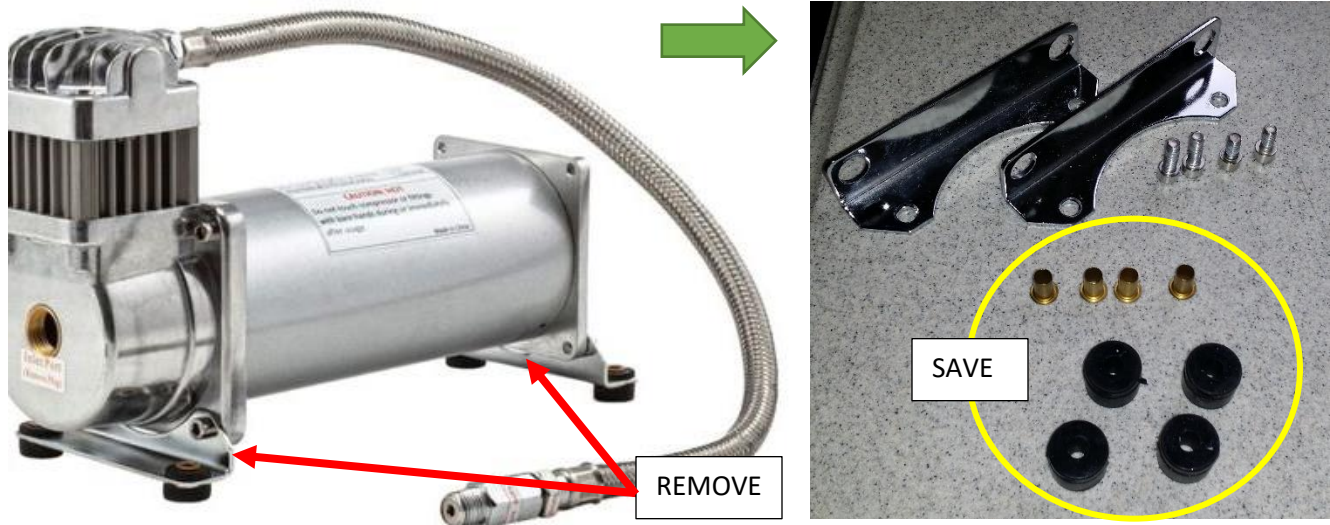

Figure 5 - Air Tank Exploded View

### 9.2. Install Rubber Compressor Bushings & Bolts

- 9.2.1. Remove Compressor from packaging, then remove Brass sleeves and Rubber bushings from chrome feet; then set aside.
- 9.2.2. Using hex wrench, remove chrome feet from Compressor and discard, as shown below.



- 9.2.3. Open included hardware bag and install bolts, lock washer, and flat washer to Compressor, as shown below. Recommended to apply Medium-Strength Loctite (i.e., Blue) to threads before installing, then Torque to 20 in-lbs

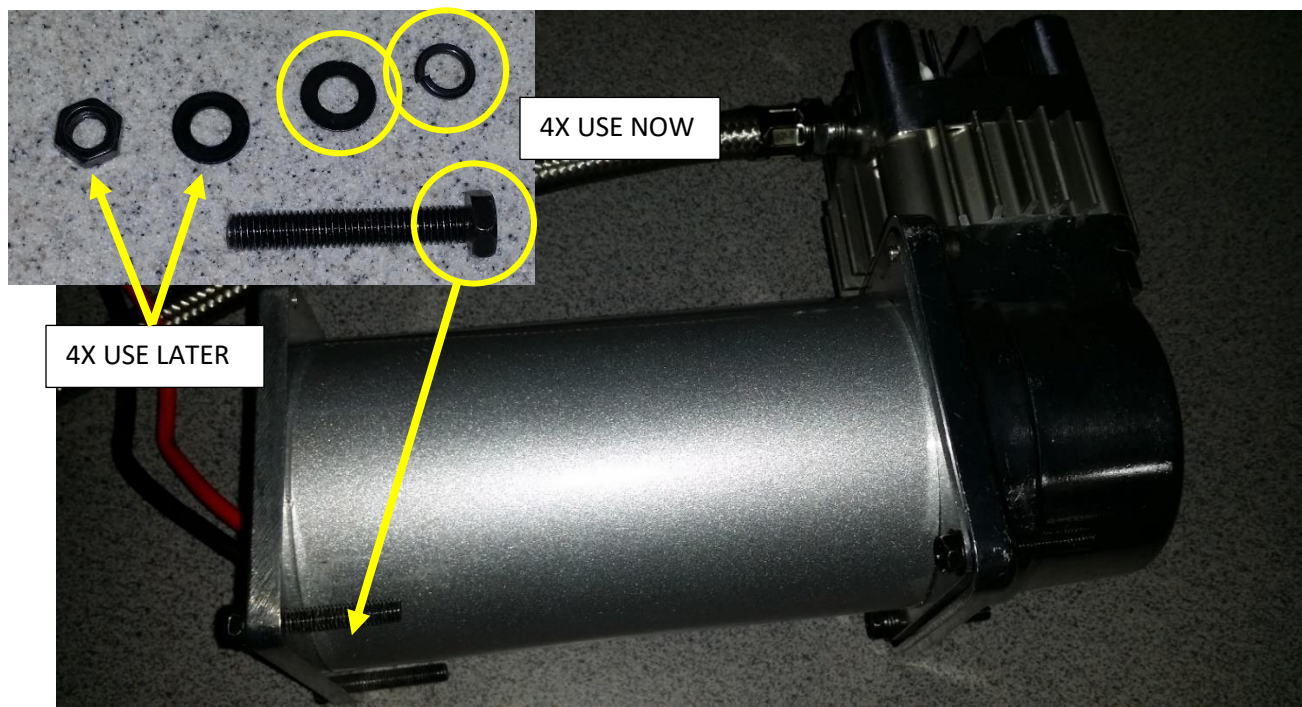

Figure 6 - Air Compressor with Bolts Installed as Studs

9.2.4. Insert Rubber bushings and Brass sleeves into Compressor Bracket, as shown below

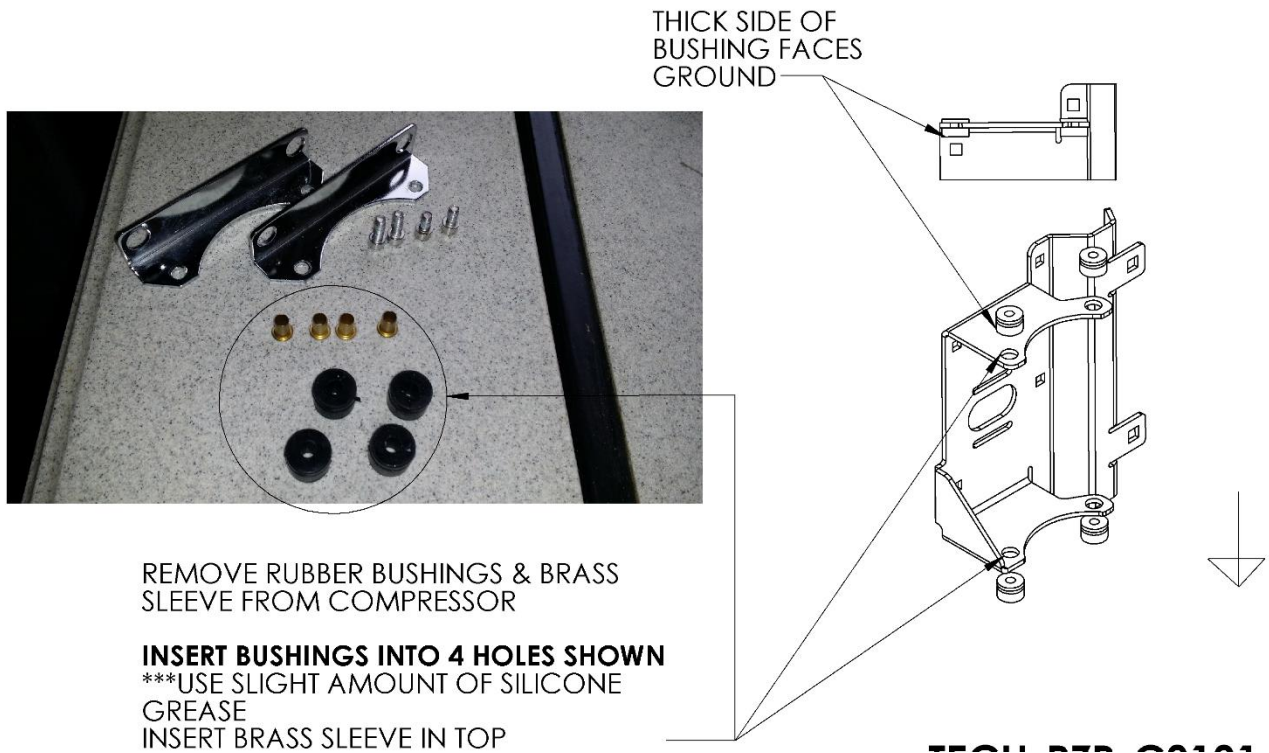

Figure 7 - Air Compressor Bracket with Rubber Grommets Installed

### 10. On-Vehicle Mechanical Assembly Steps

Complete following steps *on vehicle*.

Raise vehicle off ground using appropriate vehicle lift, ramps, or jack stands.

**DANGER:** Installation may require being underneath vehicle and applying forces to vehicle chassis. Follow all recommended safety precautions for raising vehicle; consult vehicle owner's manual.

#### 10.1. Vehicle Preparation

**Note:** All parts removed in this section will be installed after the installation of RZR1000-OBA is complete.

Refer to Owner's Manual for further instruction, or consult Shop Repair Manual, or dealership for instruction

10.1.1. On the Driver side of the vehicle, remove the Drive Belt Cooling Tube.

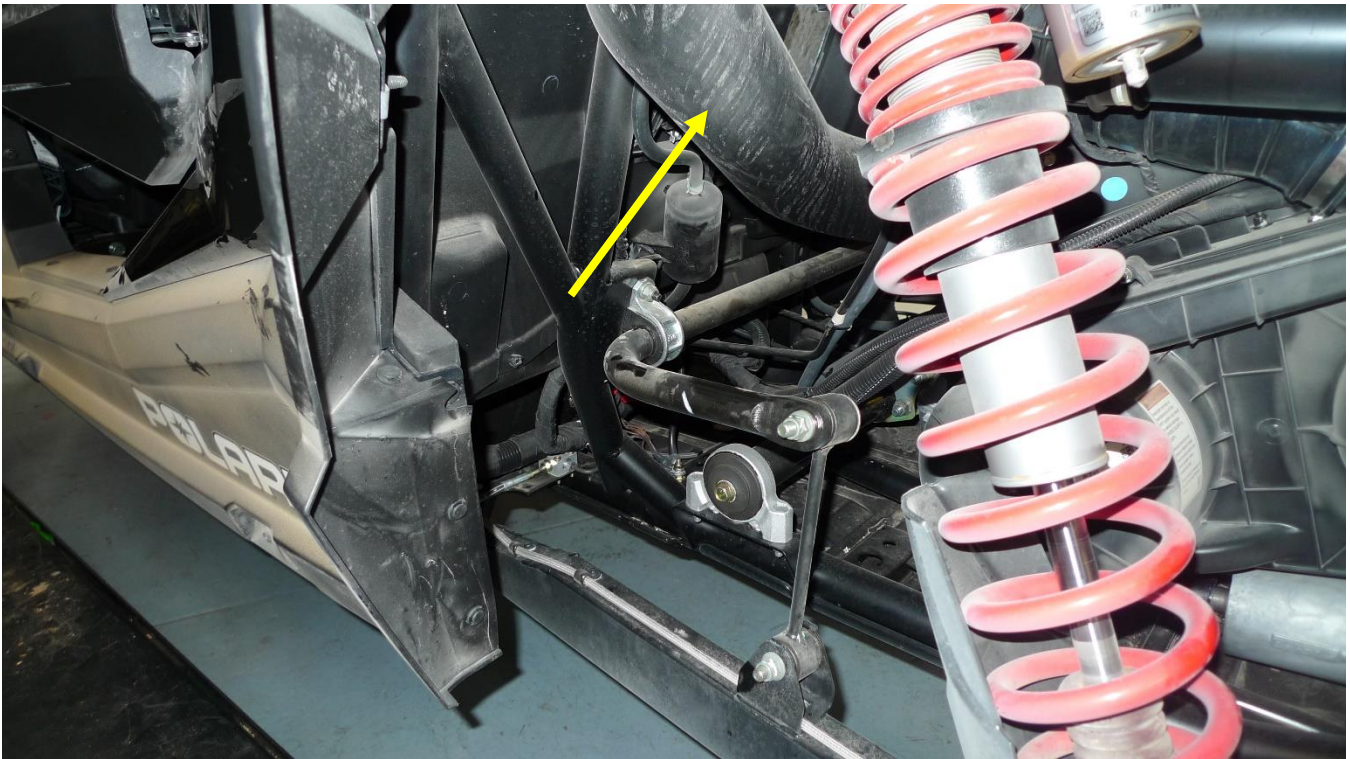

Figure 8 - Drive Belt Cooling Tubing, to Remove

10.1.2. On the Passenger side of the vehicle, remove the Air Intake Tube. Refer to Owners Manual for further instruction.

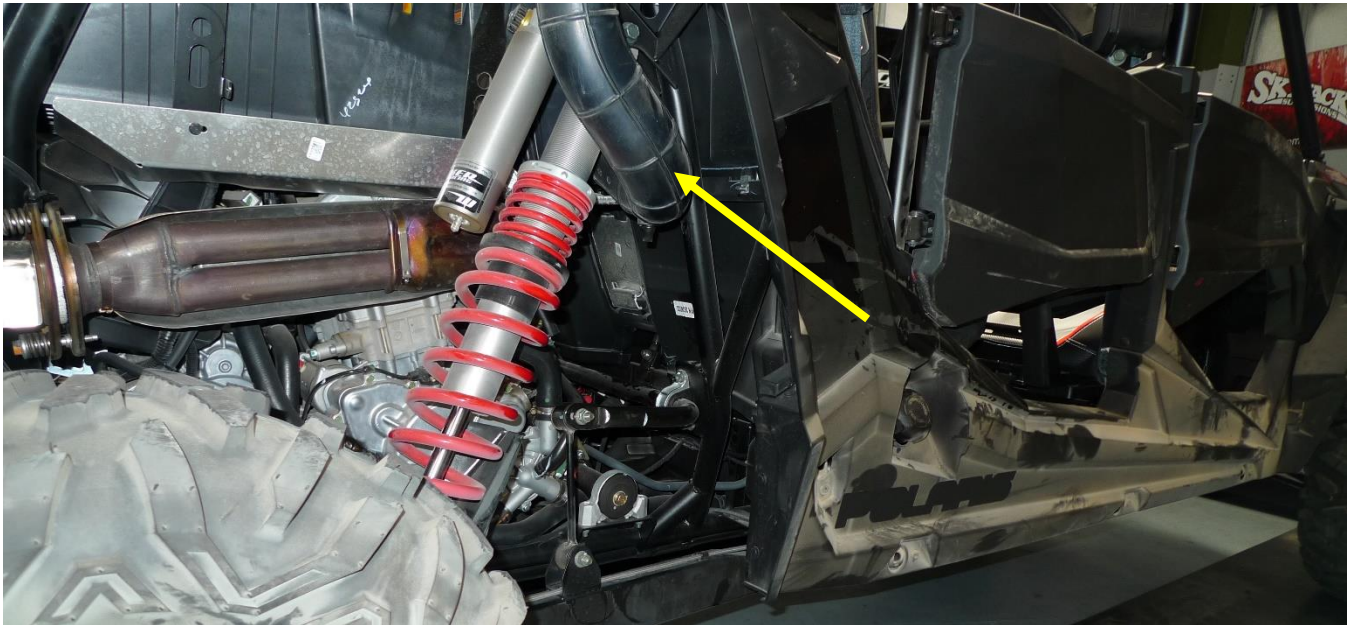

Figure 9 - Air Intake Tubing, to Remove

### 10.1.3. TURBO MODELS ONLY

1. Remove the firewall heat shield

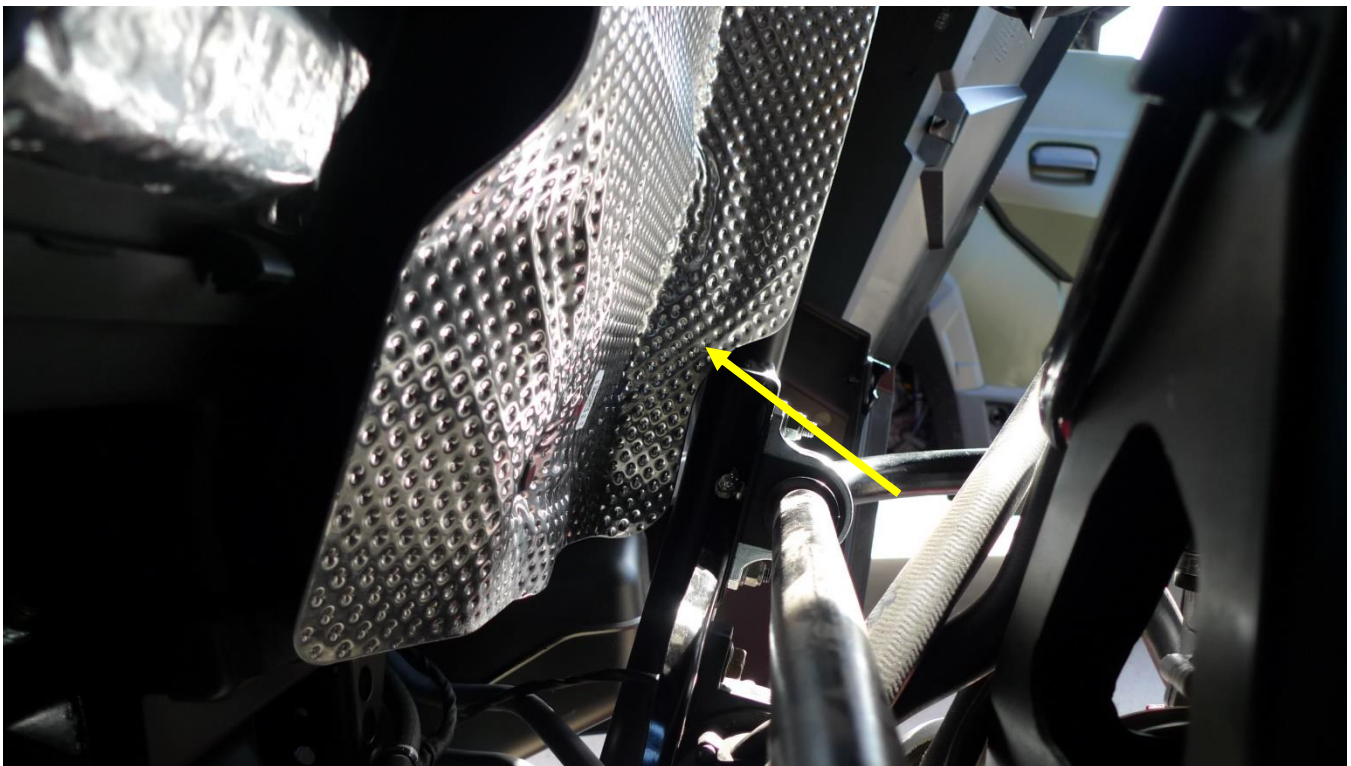

Figure 10 - Firewall Heat Shield, to Remove (Turbo Only)

### 10.2. Air Tank Brackets Installation

- 10.2.1. Using short pieces of electrical tape, or similar, temporarily attach fasteners #5 to Air Tank Brackets RZR-201, and RZR-202, before installing. ([click to return to hardware list](#))
- 10.2.2. Starting on the Passenger side of the vehicle, remove the 2 Sway Bar Bushing nuts, as shown below.
- 10.2.3. While pulling sway bar away from frame (i.e., toward back of vehicle), slide RZR-201 into space between frame and sway bar mount, sandwiching the bracket.
- 10.2.4. Re-install original hardware, and tighten loosely; bracket must be able to move side to side.
- 10.2.5. Repeat the same steps on the Driver side, instead using RZR-202.



Figure 11 - Air Tank Brackets with Air Tank Bolts taped to bottom

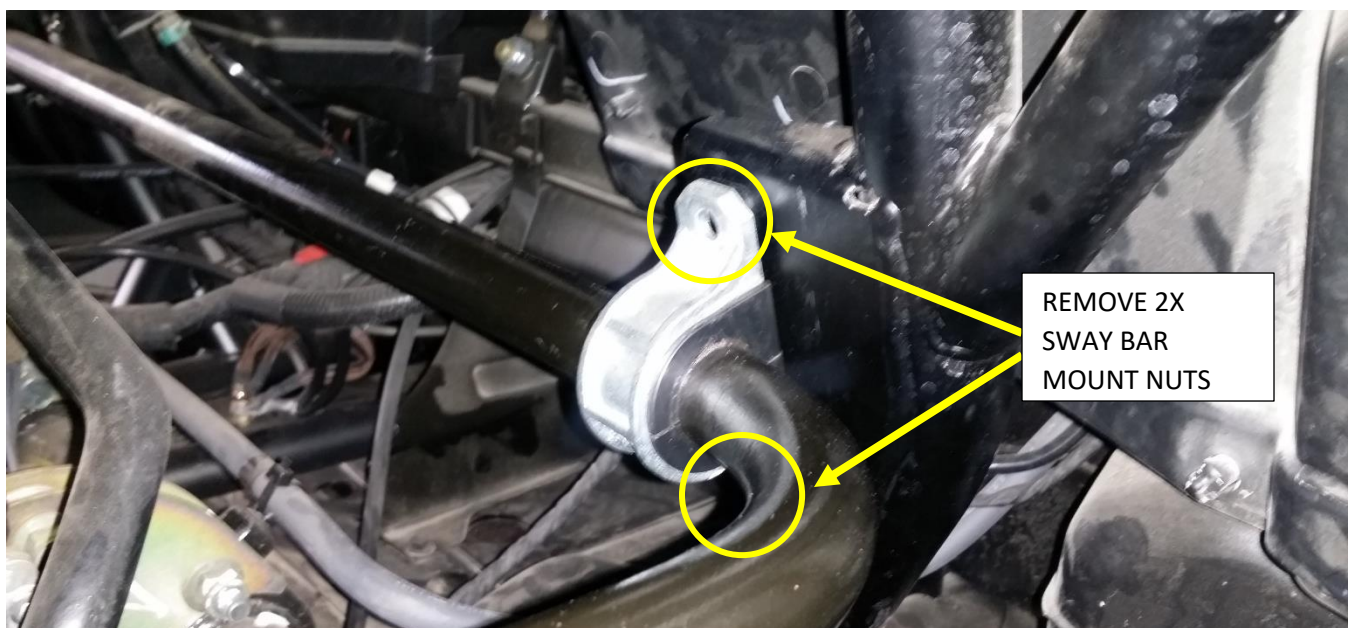

Figure 12 - Driver Side Sway Bar Nuts/Bolts, to Remove



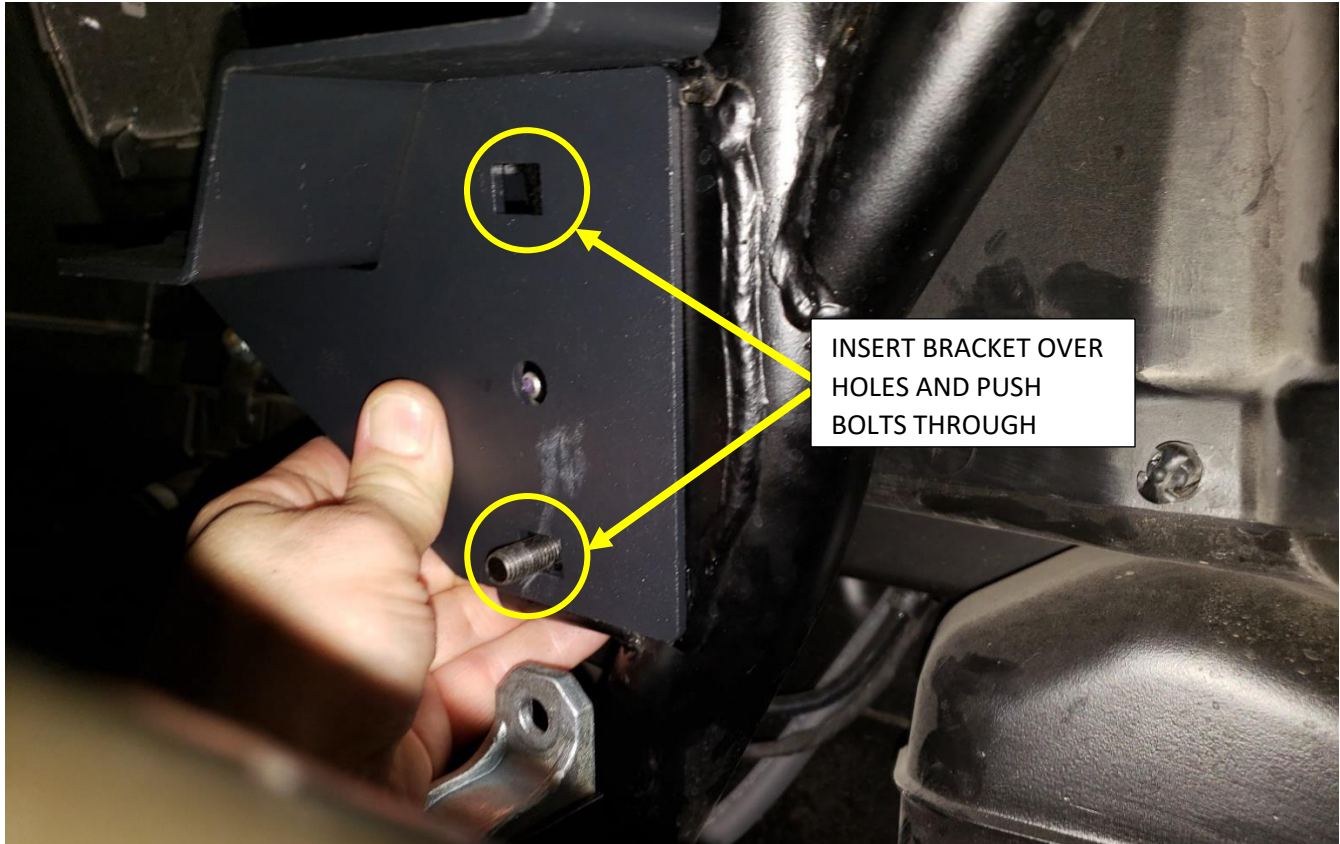

Figure 13 - Driver Side Air Tank Bracket Insertion



Figure 14 - Driver Side Sway Bar Nuts/Bolts with Air Tank Bracket Inserted

### 10.3. Air Compressor Bracket Installation

10.3.1. Attach Air Compressor Brackets, using supplied hardware to Passenger side, inner frame tube, as shown in below pictures; do not attach Compressor yet.

1. Apply Medium-Strength Loctite (i.e., Blue) to fasteners, but do not final torque



*Figure 15 - Air Compressor Bracket Installed on Frame*

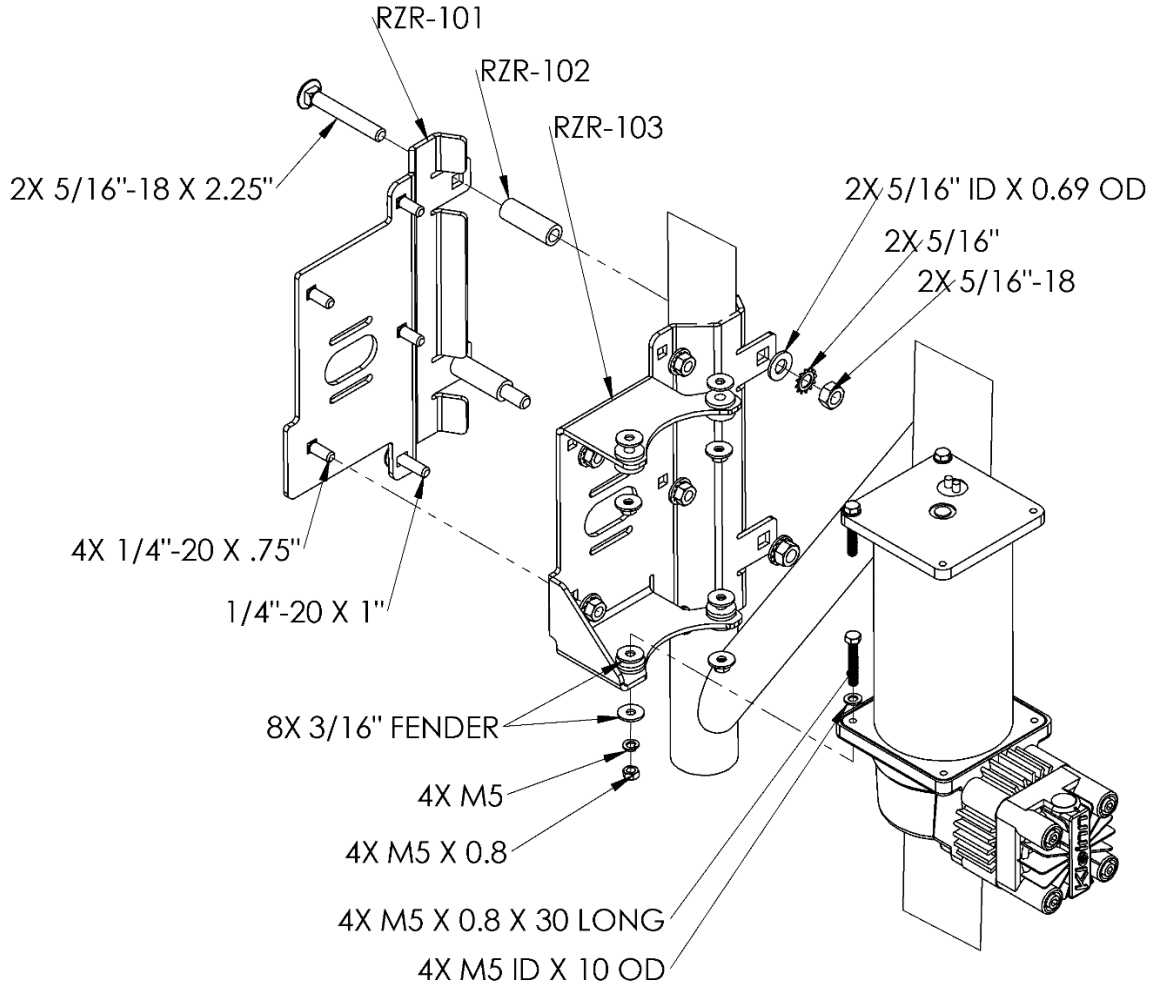

Figure 16 - Air Compressor Assembly & Hardware Exploded View

### 10.4. TURBO ONLY: Re-install Firewall Heat Shield

- 10.4.1. With Compressor Bracket installed on frame, lift it vertically along tube and rotate slightly, to provide space to insert Heat Shield.
- 10.4.2. Refer to Owner's Manual, or consult Shop Repair Manual, or Dealership for instruction on re-installing Shield.

### 10.5. Air Tank Installation, Preliminary

- 10.5.1. With Compressor Bracket installed on frame, lift it vertically along tube and rotate slightly, to provide space to insert Air Tank. Insert bench assembled Air Tank between engine and Compressor Bracket and rest on top of Brackets.
- 10.5.2. Using hardware items #5, 8, 11, and 15, install Air Tank onto Brackets, as shown below.
  - 5.1.1. Apply Medium-Strength Loctite (i.e., Blue) to fasteners, but do not final torque
  - 5.1.2. Loosely tighten hardware, so Air Tank and Brackets can slide side to side
  - 5.1.3. Position Air Tank, as necessary to maintain 1/4" clearance between vehicle and Air Tank, per below picture (i.e., use a pencil, Bic Pen, #1 Phillips screwdriver, etc. as a spacer between Firewall, Turbo and Tank)

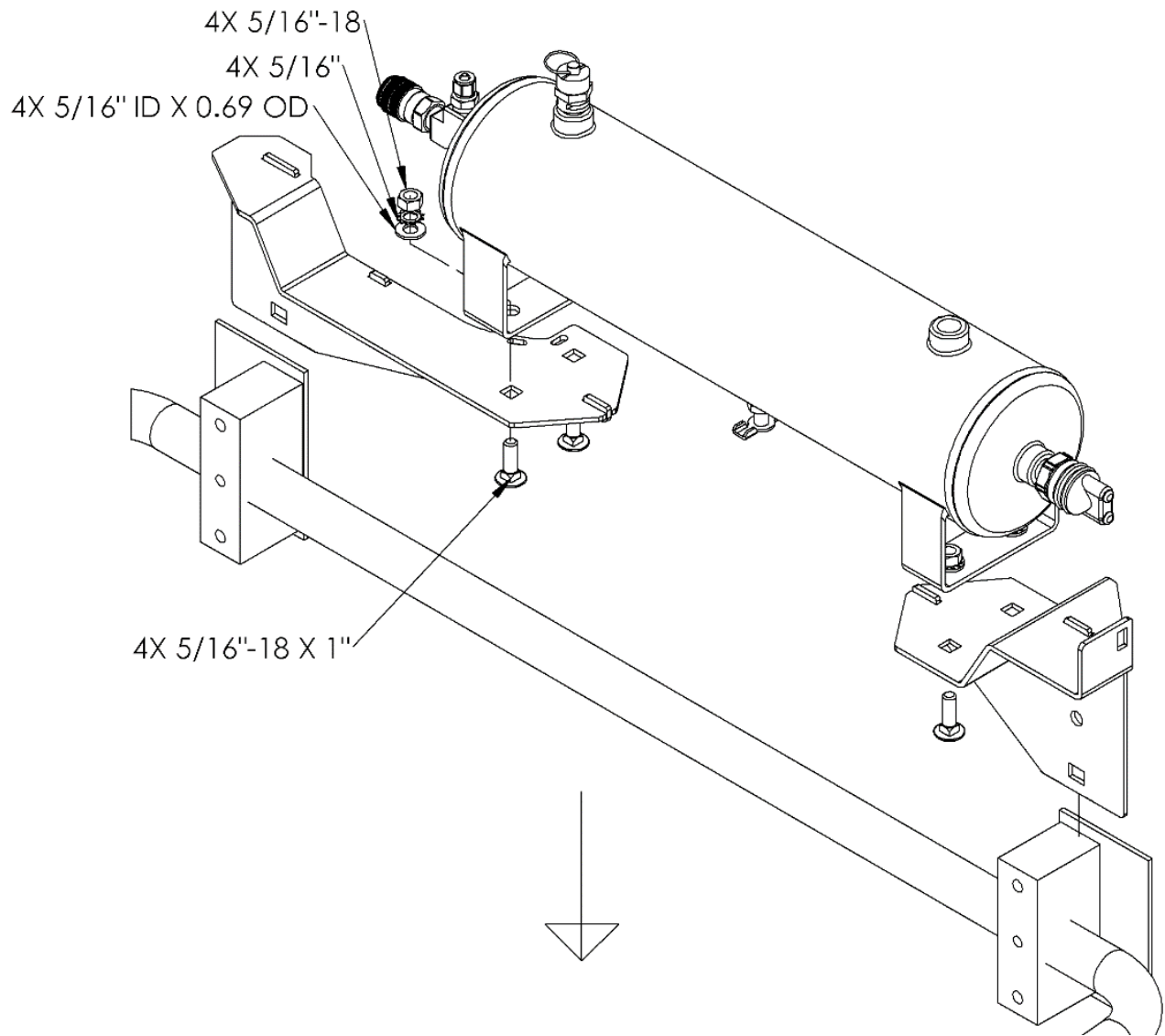

Figure 17 - Air Tank and Air Tank Brackets Exploded View

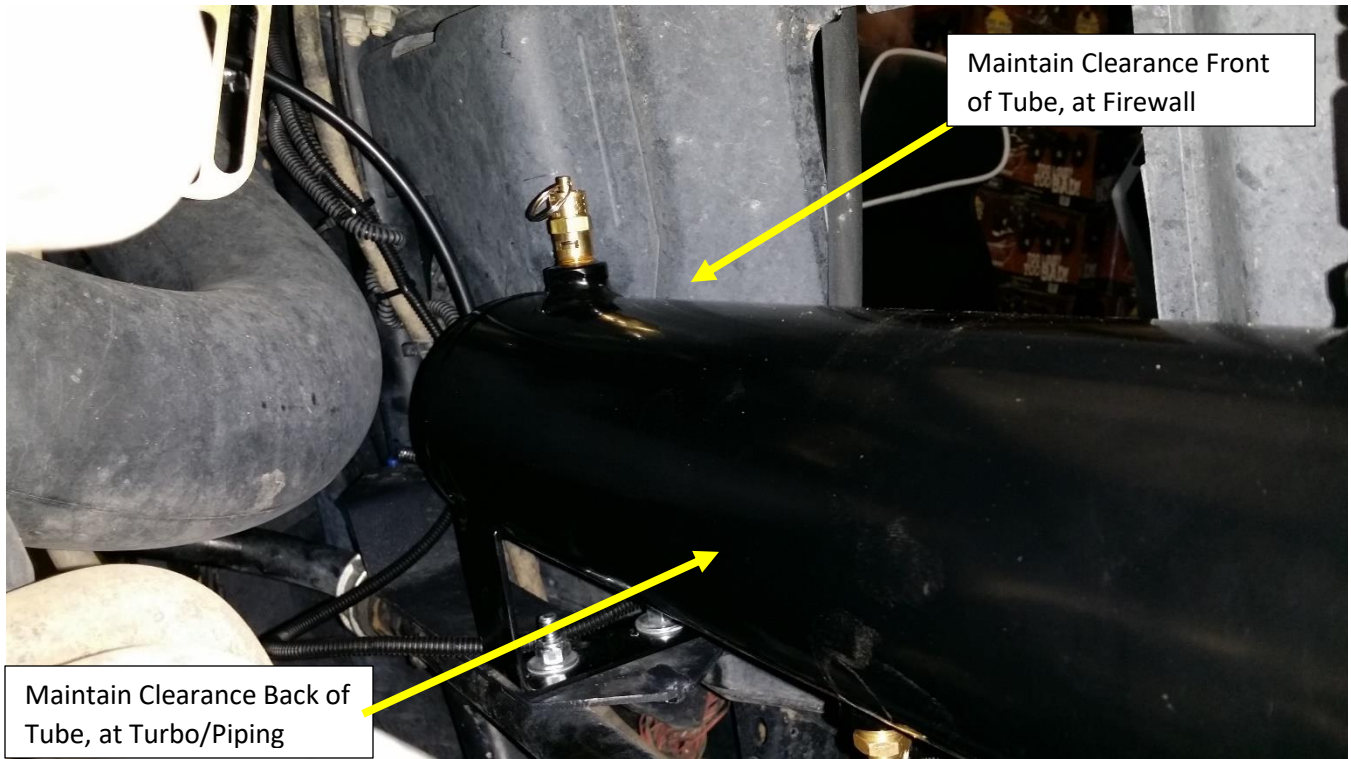

Figure 18 - Air Tank to Vehicle Clearance



Figure 19 - Air Tank Installed with Pressure Switch Wired

### 10.6. Air Compressor Installation

10.6.1. Rotate Compressor Bracket into position, so it contacts outside tab of Air Tank Bracket, then insert final 1/4"-20 X 1" carriage bolt through Air Tank Bracket into Compressor Bracket and attach flat washer, lock washer, and nut. Apply Medium-Strength Loctite (i.e., Blue) to all fasteners, if not already performed and Torque, as required:

1. 5/16" - 18 GRADE 2, 75 in-lbs
2. 1/4" - 20 GRADE 2, 37 in-lbs

10.6.2. Install Air Compressor onto Air Compressor Bracket, by sliding bolts through Brass Sleeves and Rubber Bushings. Use correct [hardware](#) items 9, 12, 13, and 16, as shown below and in [exploded view above](#).

1. Torque M5 nuts to 20 in-lbs

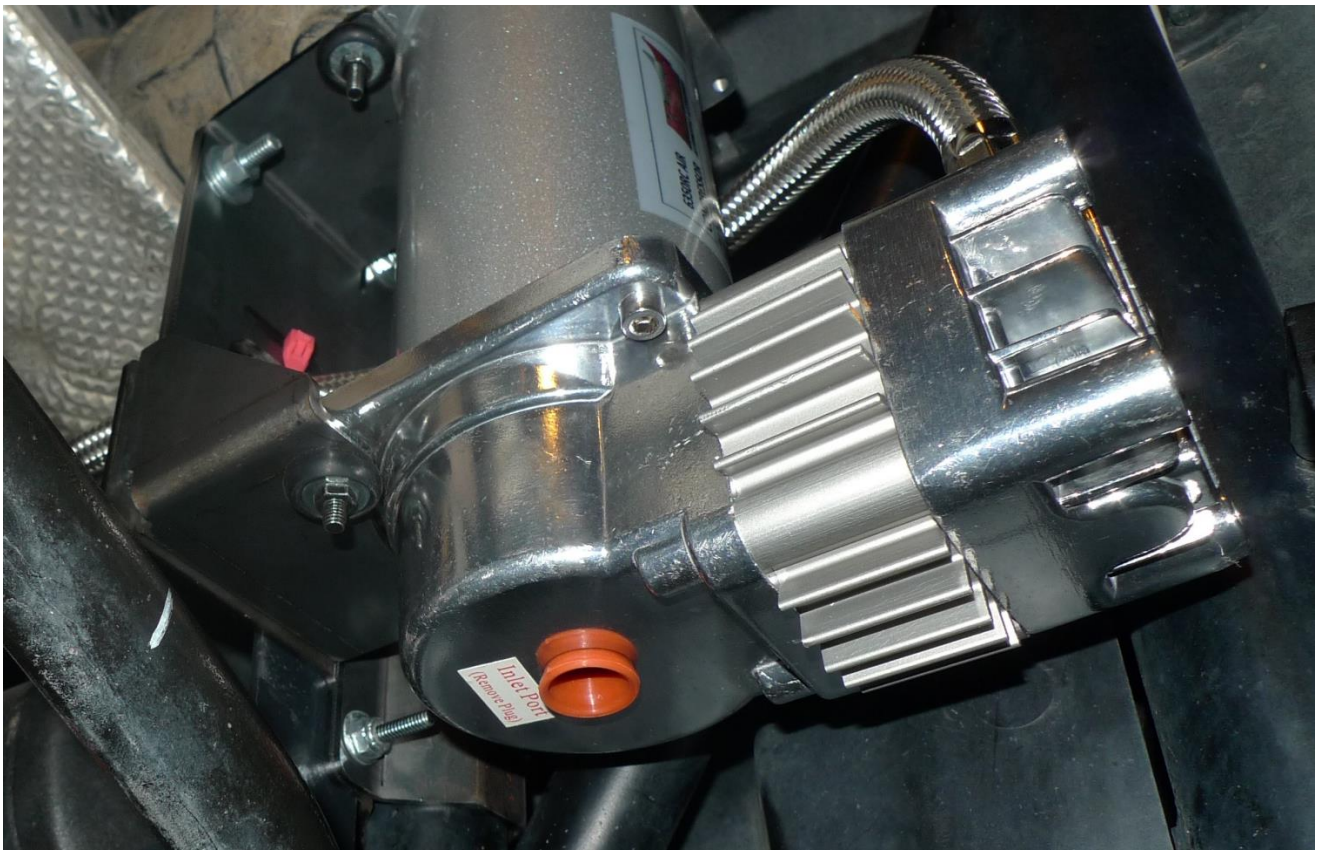

Figure 20 - Air Compressor Installed to Bracket

### 10.7. Air Tank Installation, Final

10.7.1. To best gain access to Air Tank feet bolts, it's recommended to remove inside Oil Filter access panel, as shown below

10.7.2. With Compressor Bracket fully installed on frame, ensure Air Tank has adequate clearance between vehicle, as noted above and tighten all Air Tank fasteners using following sequence:

1. Tighten Passenger Side Sway Bar Nuts; torque to 23 ft-lbs (or, use official Shop manual spec)
2. Tighten Driver Side Sway Bar Nuts; torque to 23 ft-lbs (or, use official Shop manual spec)
3. Tighten Air Tank feet to Brackets; torque to 75 in-lbs

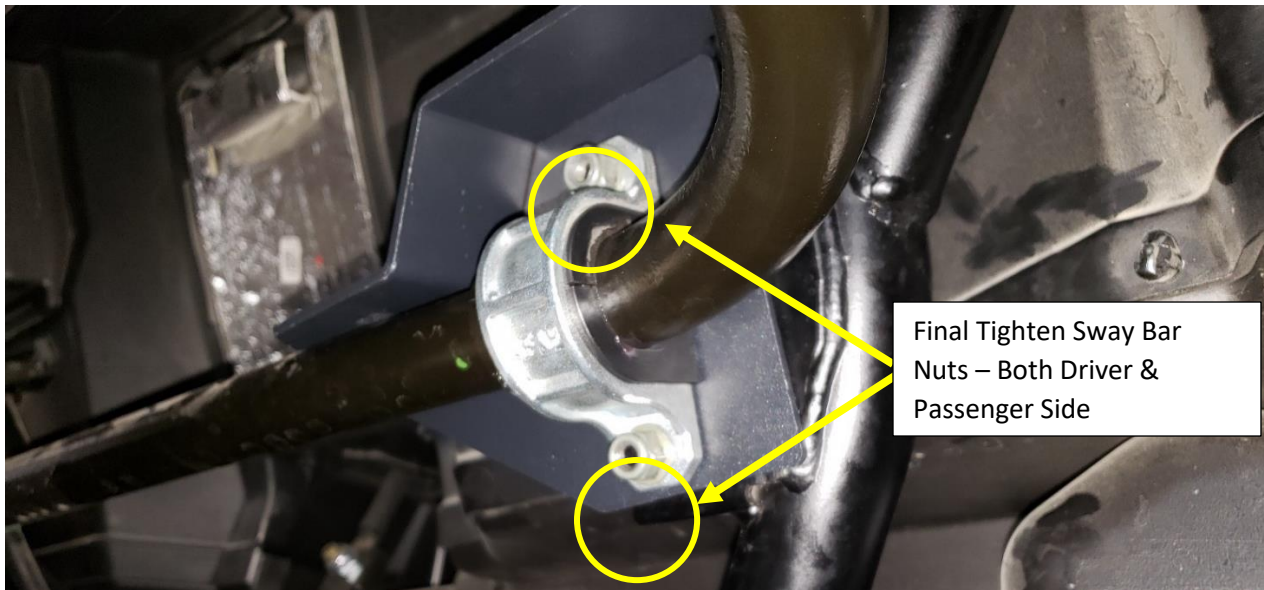

Figure 21 - Driver Side Sway Bar Final Torque of Nuts/Bolts



Figure 22 - Access to Air Tank Feet Bolts through Firewall

### 10.8. Connect Air Compressor to Air Tank and Electrical

- 10.8.1. Slide Air Compressor leader hose through slot on Air Compressor Bracket, then connect it to last available port, on passenger side top of Air Tank, as shown below.
  1. Use Kleinn Air Horn Juice on air line threads, per instruction
- 10.8.2. Use supplied plastic zip ties to hold Air Hose to Compressor Bracket.
- 10.8.3. Connect Air Compressor wiring, to previously installed wiring from Step 7

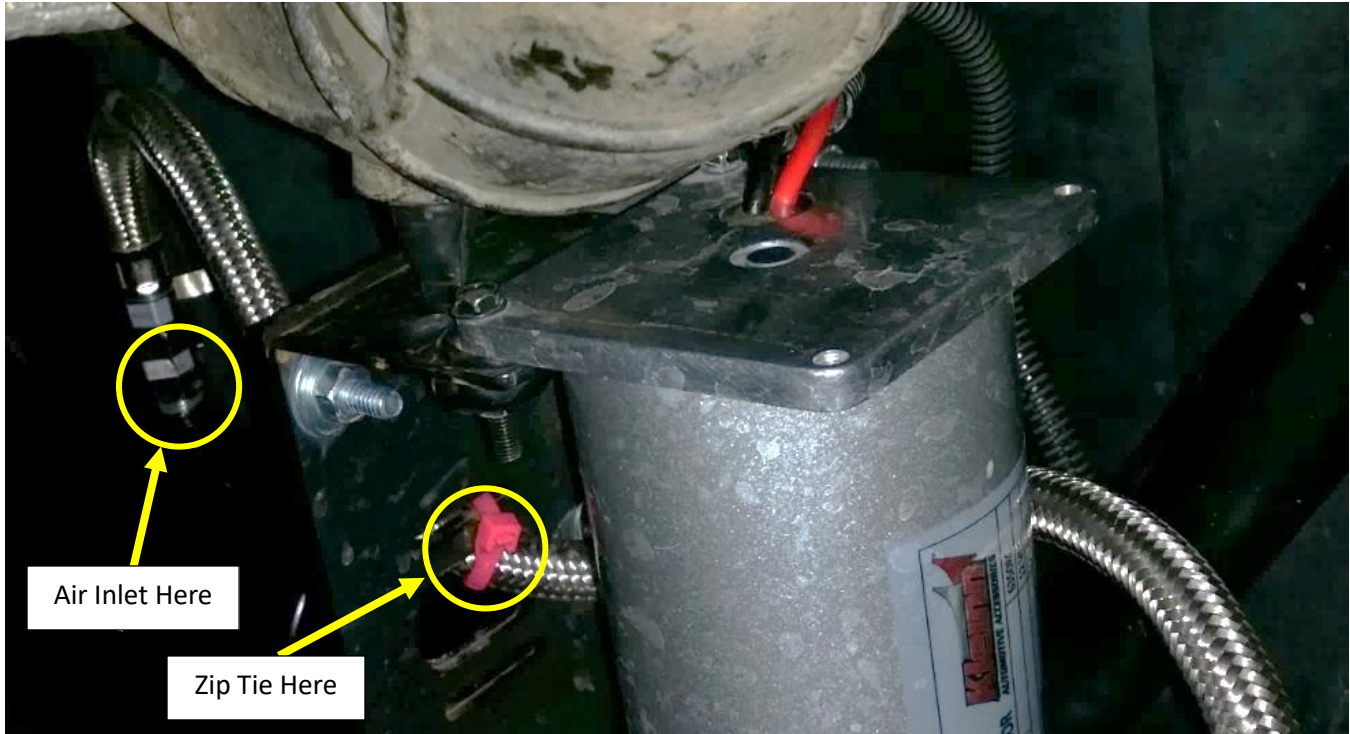

Figure 23 - Air Compressor Final Install with Leader Hose Connection to Air Tank

### 10.9. Connect Air Compressor to Inlet Filter

- 10.9.1. Pry-open plastic air filter housing and install foam filter inside.
- 10.9.2. Using included fittings, attached filter housing to front input of Air Compressor, or route and attach filter remotely, as desired.

### 10.10. Re-Connect Air Intake and Drive-Belt Cooling Tube

- 10.10.1. Follow reverse steps taken to remove these parts and verify clamps and rubber seals are properly seated.

End of Section





# RZR1000-OBA

## Installation and Operation Manual

### 11. Initial Testing of Kit

#### 11.1. Reconnect Vehicle Battery(s)

**CAUTION:** Before connecting vehicle battery(s), verify all wiring is properly connected and no shorts exists. Use of Multi-Meter, or Test Light is recommended to check continuity of all connections.

#### 11.2. Test Air Compressor

- 11.2.1. Turn vehicle ignition to on position and allow compressor to fill Air Tank. Initial fill may take approximately 1.5-3 minutes; Air Compressor should shut off automatically once full pressure is achieved.
- 11.2.2. If compressor runs excessively (i.e., 5 minutes or more), disconnect electrical power to Air Compressor and listen for air leaks in system. Repair any problems and retest; contact Kleinn technical support if problem persists.
- 11.2.3. Inspect all air line connections (i.e., Air Tank fittings, Quick Connect fittings, Air Horn fittings, etc.) for leaks by using a soap and water solution sprayed directly onto fittings
- 11.2.4. System must be pressurized or at least Air Compressor running
- 11.2.5. If an air leak is found:
- 11.2.6. Safely release air pressure from system (i.e., slowly open drain valve)
- 11.2.7. Disassemble leaky connection, re-seal and reinstall fittings as needed

#### 11.3. Test Quick Connect Coupler

- 11.3.1. Allow Air Compressor to refill tank, if needed
- 11.3.2. Attach supplied INF-1 inflator kit to Quick Connect Coupler and verify adequate air pressure is available
- 11.3.3. Test fill tires on vehicle, bicycle, etc.
- 11.3.4. Use Air Blow Gun
- 11.3.5. Use Air Impact Gun

End of Section



# RZR1000-OBA

## Installation and Operation Manual

### 12. General Operation of Kit

#### 12.1. Compressor Operation

**WARNING:** *Never operate Air Compressor above its MAXIMUM PRESSURE RATING (see label on body). Operation exceeding maximum pressure will damage Air Compressor and may result in Dangerous Air System failure.*

- 12.1.1. Air compressor is equipped with an automatic thermal overload protection circuit, designed to protect air compressor from overheating and causing permanent damage.
- 12.1.2. Automatic thermal overload protector will automatically reset after 30 minutes.
- 12.1.3. To prevent discharge of vehicle's battery and for best performance, keep vehicle's engine running while using air compressor for any prolonged use (i.e., filling tires, using air tools, etc.).

### 13. Routine Maintenance

Perform following steps at least once during recommended intervals.

- 13.1. Yearly, or every 12000 miles verify all mounting fasteners are properly torqued; applying witness marks across fasteners and mounting parts is good practice to quickly ensure fasteners have not moved.
- 13.2. Yearly, or every 12000 miles remove all road grime and mud from mounting brackets and kit parts using clean water from a garden hose; pay special attention to corners where

### 14. Warranty Information

Thank you for purchasing this RZR1000-OBA. Shall you experience any unexpected problems during installation, or have problems with any part at any time please contact Kleinn support.

dirt may collect. Touch up all paint chips using automotive grade enamel in either spray, or brush form.

NOTE: High-pressure washers may damage part finishes and *must* be used with care. Do this more frequently if traveling regularly off-road, or in winter climates where road salts are used.

13.3. Yearly, or every 12000 miles check electrical and air fitting connections and wires for abrasion, corrosion, or other damage. Replace damaged components.

NOTE: if system runs continuously or turns on unexpectedly, leaks or intermittent electrical connection may be present.

13.4. Monthly, or every 10 hours of compressor run time, drain moisture from air tank using drain valve installed at bottom of tank.

**WARNING:** *Failure to regularly drain air tank may result in corrosion inside tank and possible failure in tank or air lines, which can suddenly release air pressure causing injury to nearby people.*

13.5. Yearly, or every 12000 miles clean, or replace air compressor air filter element. Replacement frequency depends on operating frequency and conditions of operating environment (i.e., daily use of air compressor in dusty, or wet environment requires more frequent filter change). Order replacement filters at [Kleinn.com](http://Kleinn.com).

NOTE: Never lubricate or add any liquids to the included oil-less air compressor



# RZR1000-OBA

## Installation and Operation Manual

### **KLEINN MANUFACTURER LIMITED DEFECT WARRANTY:**

Kleinn Automotive Air Horns warrants this product to the end-user, when properly installed and under normal conditions of use, to be free from defects in workmanship and materials for a period of one year from the provided date of purchase, to the original purchaser of the product. This warranty does not cover abuse, operation in a manner inconsistent with the product's design, or damage resulting from exposure to the elements. If the defect is considered "under warranty", Kleinn will, at its option, repair or replace the product free of charge to the original purchaser. Kleinn is not liable for any installation charges, loss or damage of any kind incurred in the replacement or repair of any warranted product.

© Kleinn Air Horns 2018, All rights reserved.

PO Box 91278 Tucson, AZ 85752

Phone: (520) 579-1531

Web: [www.Kleinn.com](http://www.Kleinn.com)