



---

# TRX21-734

## Install Guide

Revision: B

---



© Kleinn Automotive Accessories, All rights reserved.

PO Box 91278 Tucson, AZ 85752

Phone: (520) 579-1531

Web: [www.Kleinn.com](http://www.Kleinn.com)

## Table of Contents

|      |   |    |
|------|---|----|
| 1.   | Application Chart .....                             | 4  |
| 1.1. | List of compatible vehicles .....                   | 4  |
| 1.2. | Incompatible Vehicle Features & Trim Packages ..... | 4  |
| 1.3. | Aftermarket Product Compatibility .....             | 4  |
| 2.   | Before You Start .....                              | 5  |
| 3.   | Installation Overview .....                         | 5  |
| 3.1. | Kit Layout & Location .....                         | 5  |
| 4.   | List of Tools & Supplies .....                      | 6  |
| 4.1. | Required Tools .....                                | 6  |
| 4.2. | Specialty Tools .....                               | 6  |
| 4.3. | Consumables .....                                   | 6  |
| 5.   | Parts List .....                                    | 7  |
| 5.1. | Primary Kit Components .....                        | 7  |
| 5.2. | Fittings & Related Items .....                      | 7  |
| 5.3. | Electrical Components & Related Items .....         | 8  |
| 5.4. | Mounting Brackets .....                             | 8  |
| 5.5. | Hardware & Related Items .....                      | 9  |
| 6.   | Recommended Routing of Air Tubing & Wire .....      | 13 |
| 7.   | Bench Assembly .....                                | 14 |
| 7.1. | Compressor Preparation .....                        | 14 |
| 7.2. | Tank Preparation .....                              | 16 |
| 7.3. | Accessory Preparation .....                         | 16 |
| 7.4. | Air Horn Preparation .....                          | 17 |
| 7.5. | Ore Bracket Preparation .....                       | 18 |
| 7.6. | Small Horn Bracket Preparation .....                | 19 |
| 7.7. | 1302 Preparation .....                              | 19 |
| 8.   | On-Vehicle Assembly .....                           | 20 |
| 8.1. | Compressor Installation .....                       | 20 |
| 8.2. | Tank Installation .....                             | 23 |
| 8.3. | Air Horn Installation – Large Horn .....            | 28 |
| 8.4. | Air Horn Installation – Small Horn .....            | 31 |



# Install Guide

# TRX21-734

- 8.5. Air Horn Installation – Medium Horn ..... 32
- 8.6. System Plumbing..... 33
- 9. On-Vehicle Electrical Installation ..... 34
  - 9.1. Solenoid Connector – Reconfigure & Wiring ..... 34
  - 9.2. Attach Relay & Fuse to Vehicle ..... 36
  - 9.3. Install Horn Button..... 36
  - 9.4. Route Wiring & Make Connections..... 36
- 10. Testing the Air System ..... 37
  - 10.1. Air Compressor Test..... 37
  - 10.2. Air Horn Test ..... 37
  - 10.3. Quick Connect Coupler Test..... 37
- 11. Maintenance ..... 38
- 12. Warranty Information..... 39



## 1. Application Chart

This kit is a direct bolt-on aftermarket product. The vehicles listed in the below table are considered to be compatible with this aftermarket kit. Every effort has been made to verify fitment on these vehicles in their factory condition.

*NOTE: Before unpacking your kit, review this manual in full & verify the correct space & mounting locations exist with your trim package.*

### 1.1. List of compatible vehicles

| Year        | Make | Model | Drivetrain | Engine               | Cab  | Bed  | Trim |
|-------------|------|-------|------------|----------------------|------|------|------|
| 2021 - 2024 | RAM  | TRX   | 4x4        | 6.2L Supercharged V8 | Crew | 5'7" | All  |

*NOTE: Drilling holes may be required for installing ground wires and switches based on installers preference.*

### 1.2. Incompatible Vehicle Features & Trim Packages

This kit may not be compatible with the following vehicle features / trim packages:

- MOPAR Power Steps

### 1.3. Aftermarket Product Compatibility

*This kit has been designed to be compatible with the following products from leading manufacturers:*

- Amp Research PowerStep Series

*This kit has not been designed to be compatible with the following products:*

- N/A

## 2. Before You Start

Read this manual in its entirety before starting installation. Verify you have all the parts listed & that you clearly understand the installation procedure. Contact KLEINN Technical Support with any questions you may have.

Installation of this kit requires moderate mechanical aptitude.

Use the proper tools, supplementary lighting, and safety equipment when installing this kit.

## 3. Installation Overview

### 3.1. Kit Layout & Location

| Item No. | Description           | Mounting Location                          | Approx. Install Time |
|----------|-----------------------|--|----------------------|
| 1        | 6450RC Air Compressor | Engine Compartment, Passenger Side         | 1 Hour               |
| 2        | 6355RT Air Tank       | Above Skid Plate, Next to Shock Reservoir  | 2 Hour               |
| 3        | 730 Air Horns         | Along Frame Rails, Driver & Passenger Side | 3 Hours              |
| 4        | *1302 Relocation Kit  | To be determined by Installer/Customer     | N/A                  |

\*Item Not Illustrated

Note: Wiring time is not factored into the overall install of this kit.

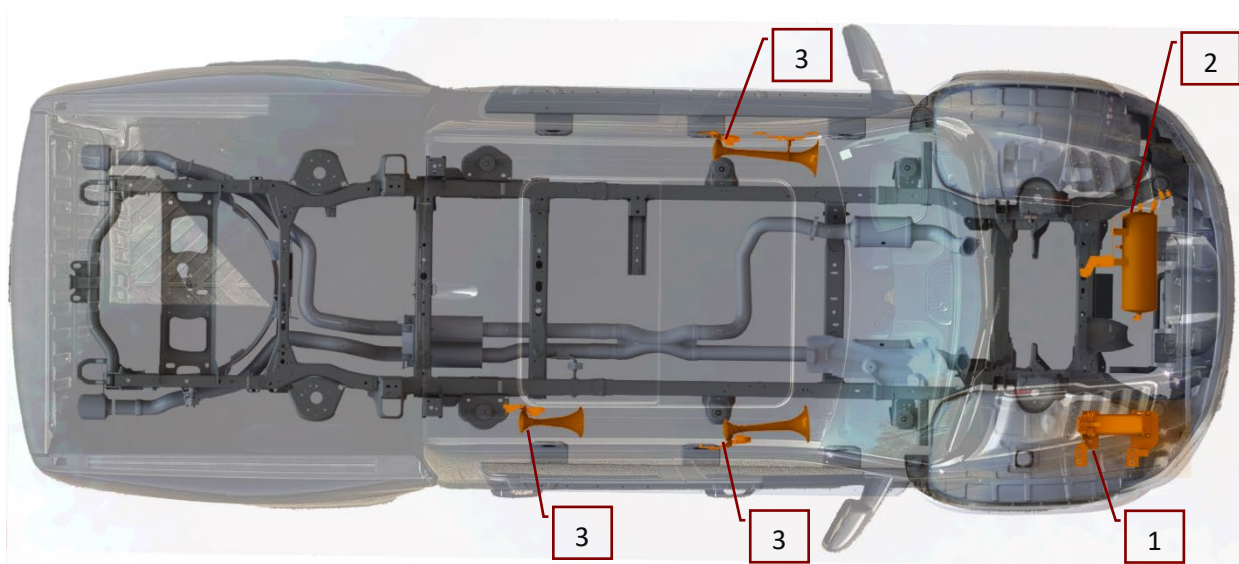

Figure 1- Kit Layout

## **4. List of Tools & Supplies**

### **4.1. Required Tools**

- Mechanic's 1/4" & 3/8" Drive & Socket Set – Imperial & Metric
- Combination wrenches – Imperial & Metric
- Hex wrenches – Imperial & Metric
- Screwdriver Set – #1, #2
- Wire Cutters
- Wire Strippers
- Wire Crimpers
- Utility Knife or Equivalent
- Magnetic Retrieval Tool (Flexible)

### **4.2. Specialty Tools**

- 1/4" & 3/8" Universal Joints
- 1/4" & 3/8" Extensions
- Multimeter, Test Light, or Equivalent
- Heat Gun
- Trim Panel Removal Tools
- Drill Driver & Bits
- Impact Driver & Bits

### **4.3. Consumables**







- Quality Electrical Tape
- Medium Strength Thread Locker
- Sandpaper, Wire Brushes or Equivalent
- Extra Zip Ties
- Touch-up Paint

## 5. Parts List





Unpackage & organize the kit contents and verify all parts listed below are included. Contact KLEINN Support if any questions arise.





### 5.1. Primary Kit Components

*NOTE: Items in this section may come in their own packages which may include additional items, hardware, or documentation.*

| Item No. | Qty | Part No. | Description   | Picture   |
|----------|-----|----------|---|---|
| 1.       | 1   | 6450RC   | 150 PSI Waterproof Air Compressor Kit   |    |
| 2.       | 1   | 6355RT   | 3.3 Gal. Air Tank, 6-Port   |    |
| 3.       | 1   | 730      | 730 Series Air Horn Kit   |    |
| 4.       | 1   | 1302     | Quick Disconnect Air Relocation Kit<br><i>NOTE: May be located within INF-1 Bag</i> |   |
| 5.       | 1   | INF-1    | Tire Inflator Kit   |  |
| 6.       | 1   | 59830    | Digital Tire Inflator w/ Pressure Release   |  |



### 5.2. Fittings & Related Items

| Item No. | Qty | Part No. | Description                          | Picture   |
|----------|-----|----------|--------------------------------------|---|
| F1.      | 1   | 51414F   | ¼" NPT Female to ¼" Compression      |          |
| F2.      | 2   | 51414L   | ¼" NPT Male to ¼" Compression, Elbow |  |
| F3.      | 1   | 51212L   | ½" NPT Male to ½" Compression, Elbow |  |
| F4.      | 1   | 52175    | 175 PSI Pop-Off Safety Valve         |    |



|     |        |         |  |   |
|-----|--------|---------|--|---|
| F5. | 1      | 2151    | Pressure Switch,<br>110 PSI On – 145 PSI Off |  |
| F6. | 1      | 52835   | ¼" NPT Male Drain Plug                       |  |
| F7. | 2x 12' | 25014-1 | ¼" O.D. Air Tubing                           |  |
| F8. | 2      | JUICE   | KLEINN Liquid Thread Sealant                 |  |

\*NOTE if required





### 5.3. Electrical Components & Related Items

| Item No. | Qty | Part No. | Description                 | Picture   |
|----------|-----|----------|-----------------------------|---|
| -        | 1   | 320      | Momentary Switch, NO        |   |
| -        | 1   | 6858     | Wire kit w/ FT4-10 Fuse Tap |  |
| -        | 10' | SLT14    | ¼" Loom Pack                |  |
| -        | 10' | SLT38    | 3/8" Loom Pack              |   |
| -        | 10' | SLT12    | ½" Loom Pack                |   |

### 5.4. Mounting Brackets







| Item No. | Qty | Part No. | Description              | Picture   |
|----------|-----|----------|--------------------------|---|
| -        | 1   | -        | Upper Compressor Bracket |  |
| -        | 1   | -        | Lower Compressor Bracket |  |
| -        | 1   | -        | Anchor Bracket           |  |



















|   |   |   |                               |  |
|---|---|---|-------------------------------|--|
| - | 1 | - | Primary Tank Bracket          |   |
| - | 1 | - | Tank Support Bracket          |   |
| - | 1 | - | Cutaway Washer                |   |
| - | 1 | - | Passenger Horn Bracket, Sm    |   |
| - | 1 | - | Passenger Horn Bracket, Med   |   |
| - | 1 | - | Driver Horn Bracket, Lg       |   |
| - | 1 | - | Ore Mount Bracket, Left Side  |   |
| - | 1 | - | Ore Mount Bracket, Right Side |  |

### 5.5. Hardware & Related Items

Print out the hardware sheets at the end of this section at 100% Scale to facilitate hardware identification.

| Item No. | Qty | Hardware Size       | Description               | Picture   |
|----------|-----|---------------------|---------------------------|---|
| H1.      | 1   | 7/16"-14, 1" Long   | Square Neck Carriage Bolt |  |
| H2.      | 4   | 7/16"-14            | Hex Nut                   |  |
| H3.      | 1   |                     | Nylon Lock Nut            |  |
| H4.      | 4   | 7/16"               | SAE Washer                |  |
| H5.      | 4   |                     | Split-Lock Washer         |  |
| H6.      | 2   | 5/16"-18, 3/4" Long | Square Neck Carriage Bolt |  |

|      |   |                      |                   |   |
|------|---|----------------------|-------------------|---|
| H7.  | 1 | 5/16"-18, 1/2" Long  | Hex Bolt          |    |
| H8.  | 2 | 5/16"-18             | Hex Nut           |    |
| H9.  | 2 | 5/16"                | SAE Washer        |    |
| H10. | 1 |                      | USS Washer        |    |
| H11. | 2 |                      | Split-Lock Washer |    |
| H12. | 1 | 1/2"-13, 1" Long     | Hex Bolt          |    |
| H13. | 1 | 1/2"-13              | Hex Nut           |    |
| H14. | 1 | 1/2"                 | Fender Washer     |    |
| H15. | 1 |                      | Split-Lock Washer |    |
| H16. | 1 | M8 x 1.25, 50mm Long | Hex Bolt          |    |
| H17. | 1 | M8 x 1.25, 35mm Long |                   |   |
| H18. | 2 | M8 x 1.25, 25mm Long |                   |   |
| H19. | 6 | M8 x 1.25            | Hex Nut           |    |
| H20. | 6 | M8                   | Flat Washer       |   |
| H21. | 6 |                      | Split-Lock Washer |  |
| H22. | 2 | 13/16" OD, 5/16" ID  | Rubber Grommet    |  |
| H23. | 2 | 3/4" OD, 7/16" ID    | Rubber Grommet    |  |
| H24. | 4 | M8 x 1.25            | Flange Nut        |  |

\*Not Illustrated on the Scale Sheets

2

1

B

B

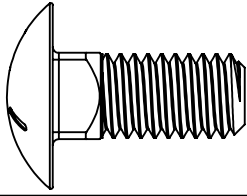
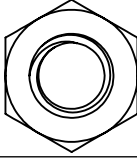
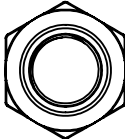
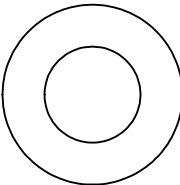
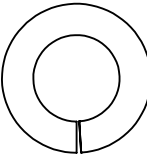
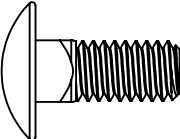
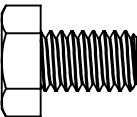
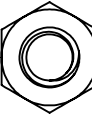
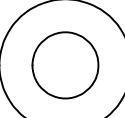
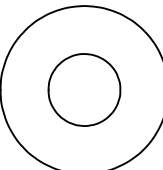
| Item # | Qty | Scale Image   |
|--------|-----|---|
| H1     | 1   |    |
| H2     | 4   |    |
| H3     | 1   |    |
| H4     | 4   |    |
| H5     | 4   |   |
| H6     | 2   |  |
| H7     | 1   |  |
| H8     | 2   |  |
| H9     | 2   |  |
| H10    | 1   |  |

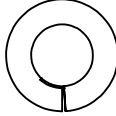
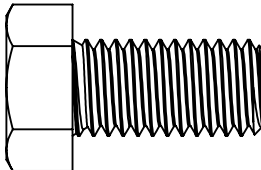
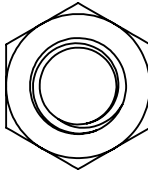
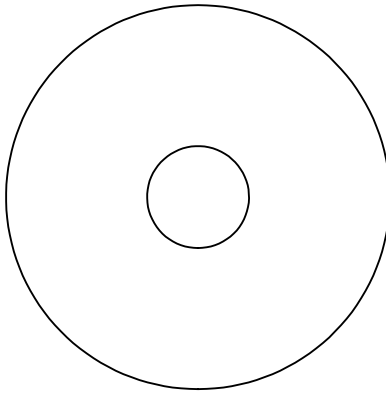
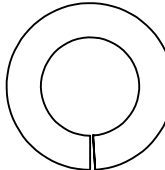
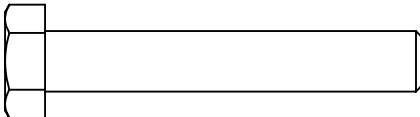
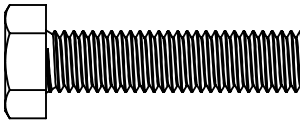
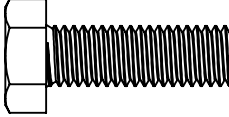
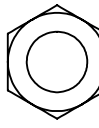
| Item # | Qty | Scale Image   |
|--------|-----|---|
| H11    | 2   |    |
| H12    | 1   |    |
| H13    | 1   |    |
| H14    | 1   |   |
| H15    | 1   |  |
| H16    | 1   |  |
| H17    | 1   |  |
| H18    | 2   |  |
| H19    | 6   |  |

A

A

TRX21-734  
Sheet Scale 1:1

[mm]  
inches



2

1

2

1

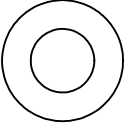
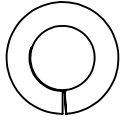
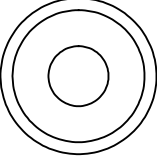
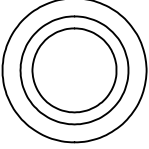
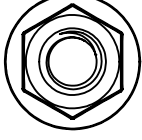
| Item # | Qty | Scale Image   |
|--------|-----|---|
| H20    | 6   |  |
| H21    | 6   |  |
| H22    | 2   |  |
| H23    | 2   |  |
| H24    | 4   |  |

B

B

A

A

TRX21-734  
Sheet Scale 1:1

[mm]  
inches



2

1

## 6. Recommended Routing of Air Tubing & Wire

The below figures are a recommendation of the routing paths for both the air tubing & the wiring. Verify routing paths, wire lengths, & fuse/relay component locations before cutting the included wire. Reference Section 9 (On-Vehicle Electrical Installation) for a detailed electrical connection guide.

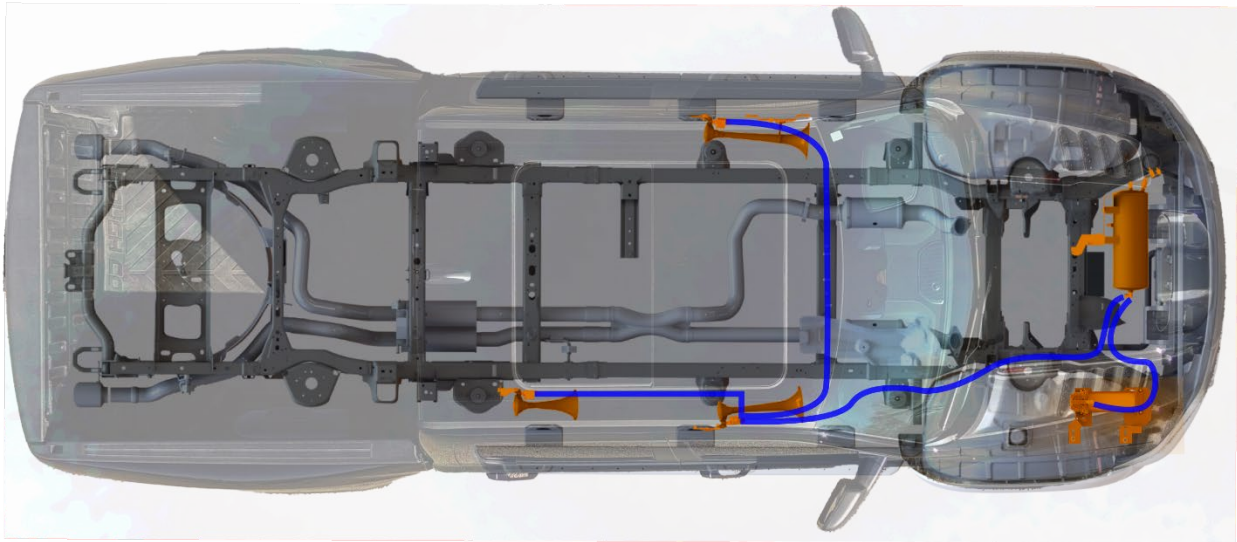

Figure 2- Suggested Air Tubing Routing

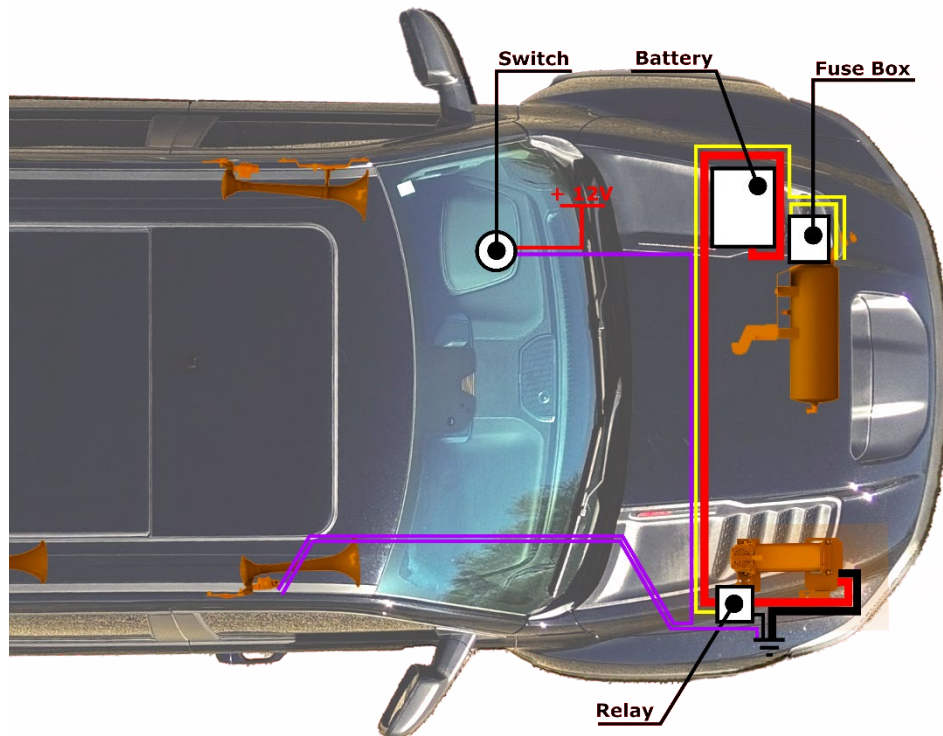

Figure 3- Suggested Electrical Routing

## 7. Bench Assembly

### 7.1. Compressor Preparation

- 1) Install rubber grommets H22 & H23 on the Upper Compressor Bracket & Lower Compressor Bracket. **Note the internal hole diameter of the grommets and their placement.**

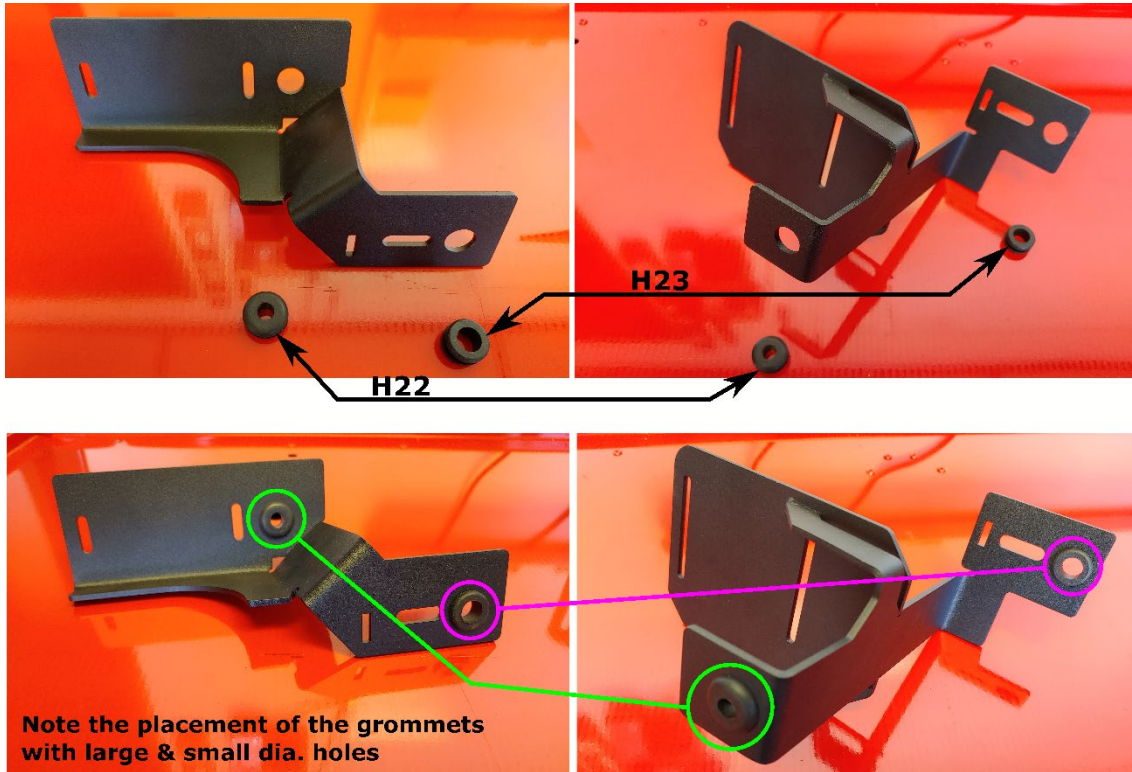

Figure 4- Grommet Installation

- 2) Install the compressor onto the smaller of the above illustrated brackets.
  - a. Use the hardware included in the compressor box & **install it in an upside-down configuration** as shown in the below figure.
  - b. **Fully secure the compressor onto the small bracket. Do NOT overtighten the hardware.**

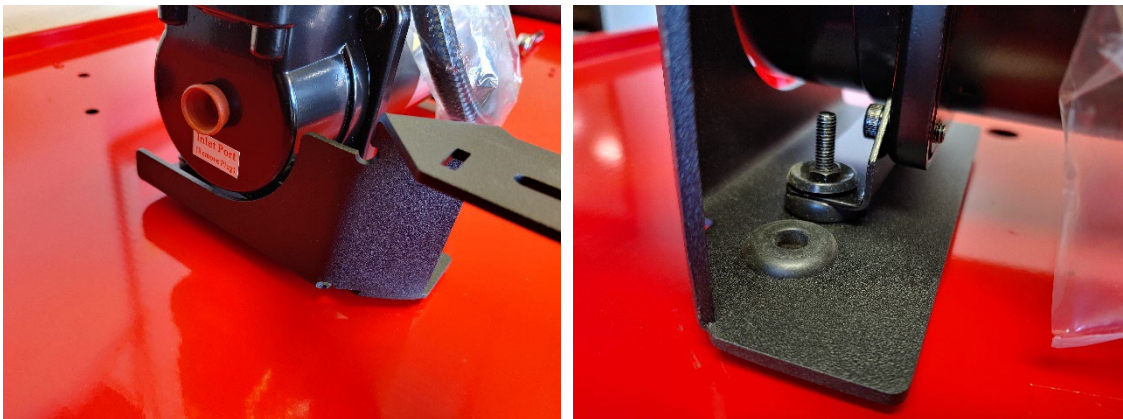

Figure 5- Compressor-To-Bracket Installation 1

- 3) Loosely install the compressor onto the larger of the two brackets as shown below.
  - a. Install the hardware in an upside-down configuration as before.
  - b. **Keep the hardware loose so the bracket can slide back and forth without difficulty.**

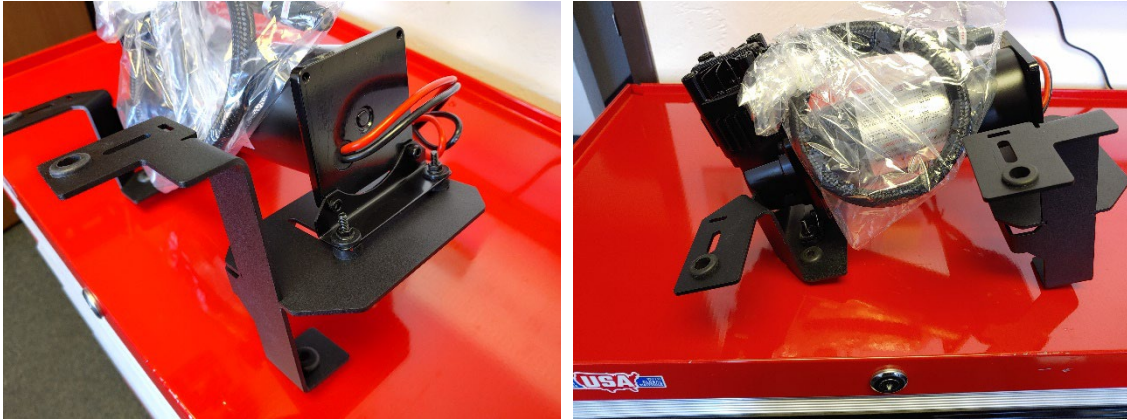

Figure 6- Compressor-To-Bracket Installation 2

- 4) Install the compressor air filter onto the inlet port or use the fitting pack and instructions (included in the box) to set up the remote air intake (snorkel).
- 5) Use fitting F1 & 2-3 drops of JUICE liquid thread sealant (F8) and install the fitting onto the compressor leader hose.

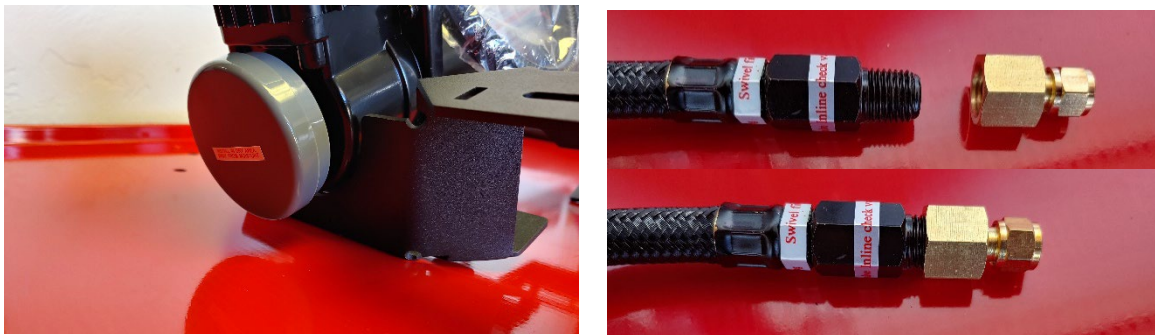

Figure 7- Air Filter & Compressor Fitting Installation

## 7.2. Tank Preparation

- 1) Using the JUICE liquid thread sealant (F8), install all fittings onto the air tank, the INF-1 Kit & the tire inflator as shown in the below figures.

*NOTE: One fitting used on the tank is from the fitting pack located in the 1302 Quick Disconnect Air Relocation Kit, which may be located in the INF-1 bag.*

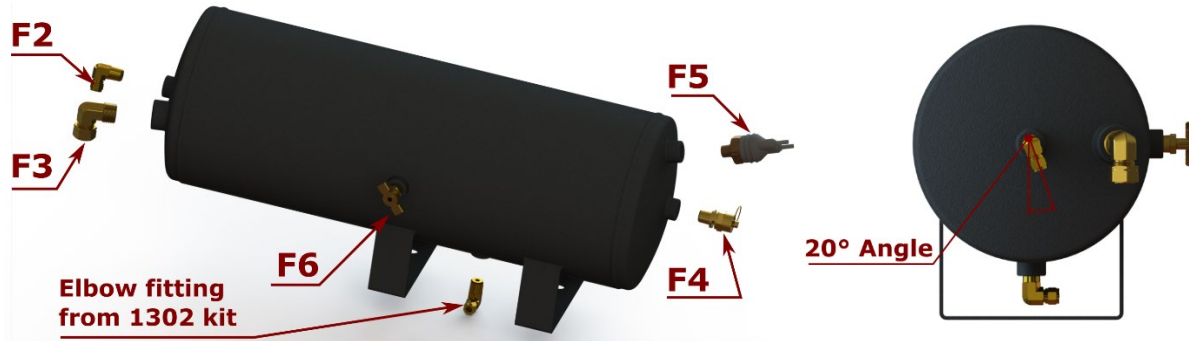

Figure 8- Tank Fitting Installation

- 2) After all tank fittings have been installed, use the 1/4" air tubing located within the INF-1 bag and install the tubing onto the 1/4" elbow fitting from the 1302 kit.

## 7.3. Accessory Preparation

Use JUICE (F8), and combining all the fittings from the INF-1 Kit & the Digital Tire Inflator, install the fittings onto the hose & the tire inflator so that the INF-1 kit & tire inflator can be used as standard air tools.

See the below figure for reference.



Figure 9- Accessory Fittings Installation



## 7.4. Air Horn Preparation

- 1) Detach all air horns from the mounting bar & discard it & the white plastic base protectors.
- 2) Separate the three horns from each other by detaching the air tubing from each horn.
- 3) Separate the medium & long trumpets from their respective base by unscrewing the trumpets in a counter-clockwise direction.



Figure 10- Air Horn Separation

- 4) Install the solenoid block onto the base with the fittings & disconnect the wire plug.
  - a. Ensure the solenoid is positioned parallel & does not interfere with the trumpet fitting.
  - b. Ensure the directional arrow stamped on the solenoid is pointing towards the base.
  - c. The wire plug is removed via a Phillips head screw from the back of the connector, unscrew & pull the plug away from the solenoid.
- 5) Replace the straight ¼" compression fitting with the remaining F2 fitting (use JUICE) in the correct orientation & location. See the below figure.
- 6) Install the large compression fitting onto the solenoid using JUICE.

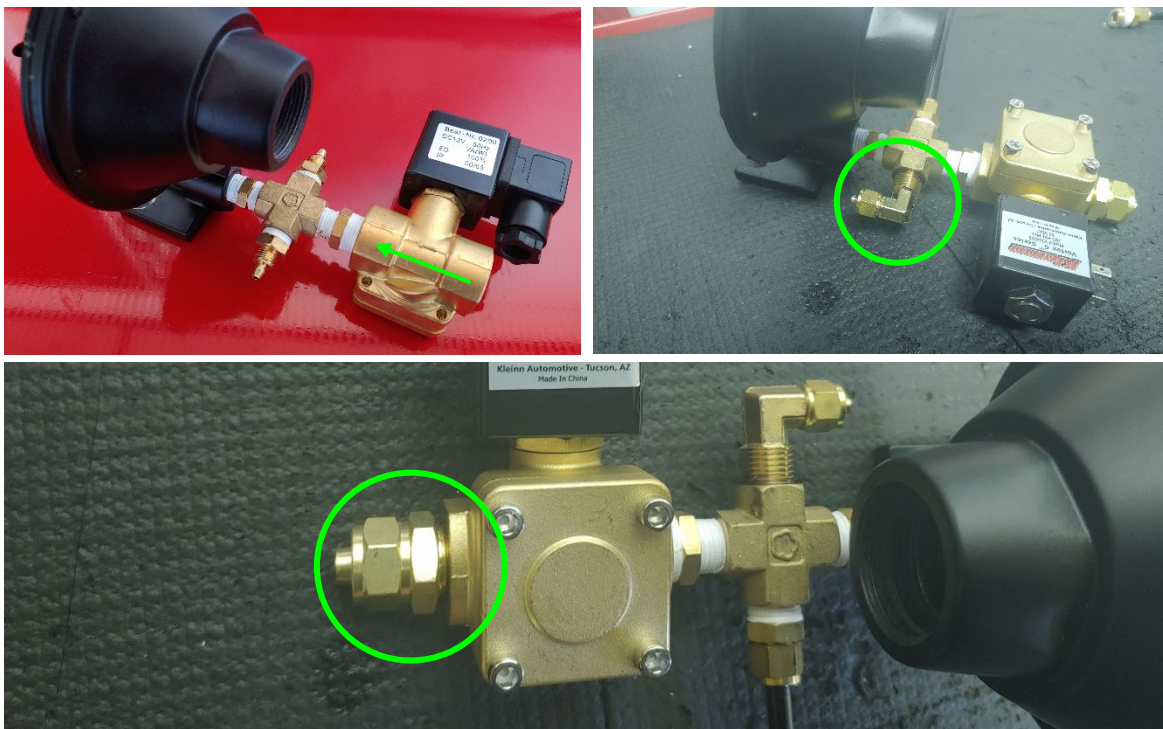

Figure 11- Solenoid Installation & Fitting Replacement

## 7.5. Ore Bracket Preparation

- 1) Using all of hardware H6, H8, H9 & H11, loosely combine both Ore Mount Brackets as shown below.
  - a. H6 carriage bolts are inserted from the underside through the left brackets square holes.



Figure 12- Ore Bracket Assembly

- 2) Use one ore from the horn box and install it onto the circular platform of the bracket using it's included hardware.
  - a. Install the flat rubber strip onto the inside of the crescent ring to protect the trumpet.
  - b. DO NOT USE the large rubber spacer when installing the ore.
  - c. Install the hardware in an upside-down configuration as shown below.
  - d. Keep the hardware loose so the Ore can be positioned after the trumpet is installed.

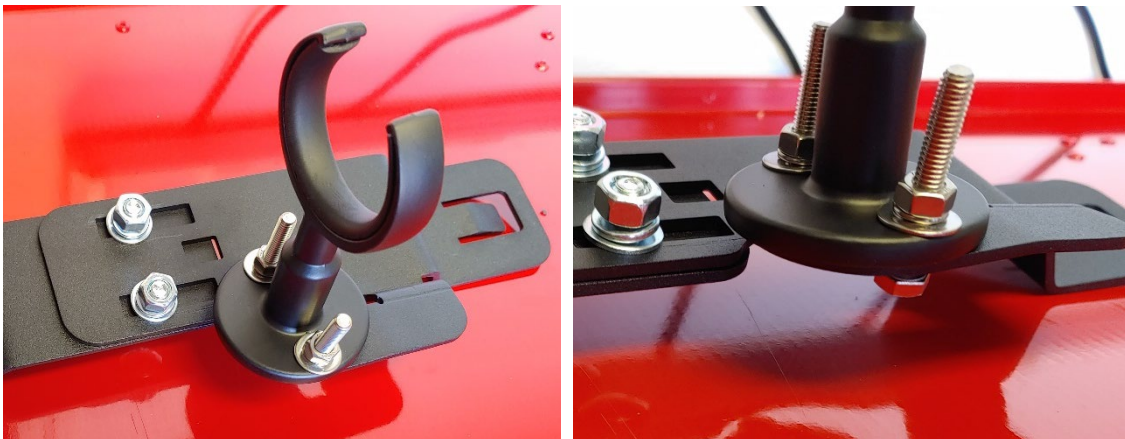

Figure 13- Ore Installation

## 7.6. Small Horn Bracket Preparation

Loosely install Qty: 2 of hardware H18, H19, H20 & H21 as shown in the below figure.

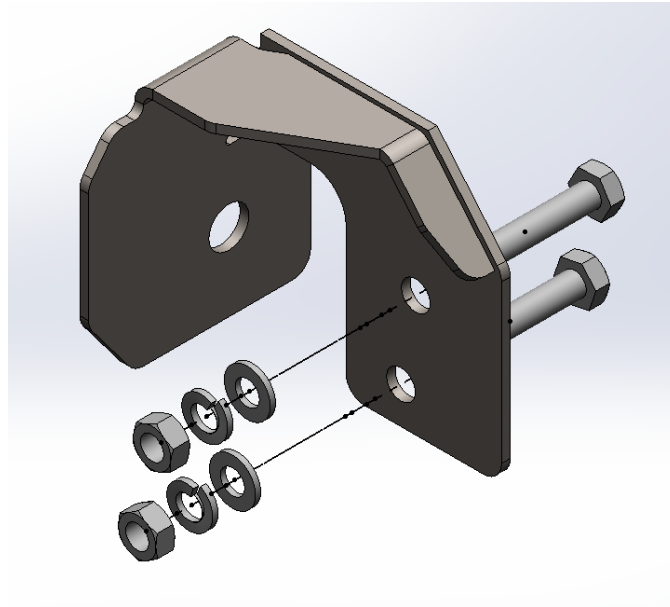

Figure 14- Passenger Horn Bracket, SM, Hardware Preparation

## 7.7. 1302 Preparation

Using JUICE (F8), assemble the 1302 kit as shown below.

| ITEM NO. | PART NUMBER | DESCRIPTION                                   | QTY. |
|----------|-------------|---|------|
| 1        | 1302-401    | 1302 RELOCATION BRACKET                       | 1    |
| 2        | 51414BLK    | 1/4" NPTF BULKHEAD FITTING                    | 1    |
| 3        | 51414       | 1/4" NPT X 1/4" COMP. TUBE FITTING            | 1    |
| 4        | 51414L      | 1/4" NPT X 1/4" COMP. TUBE FITTING, 90° ELBOW | 1    |
| 5        | 59813       | 1/4" NPT QUICK DISCONNECT, M                  | 1    |
| 6        | DUSTCAP     | DUST COVER FOR QUICK DISCONNECT               | 1    |

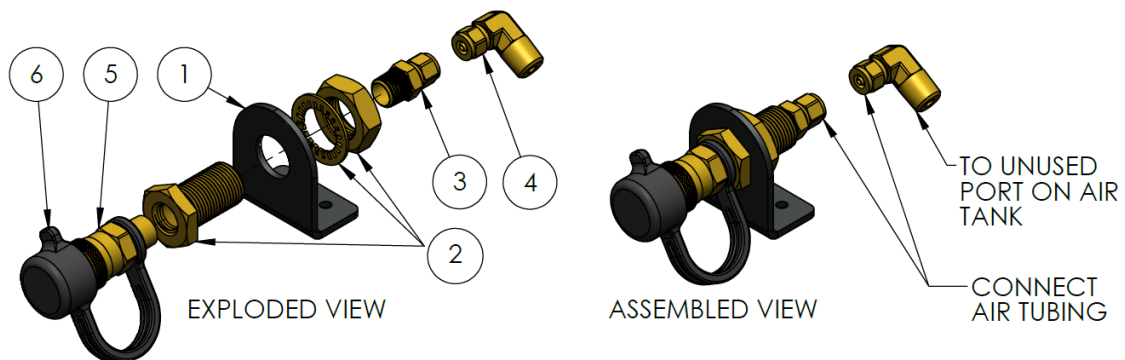

Figure 15- 1302 Kit Assembly

## 8. On-Vehicle Assembly

### 8.1. Compressor Installation

The air compressor is installed in the engine compartment, on the passenger side, above the wheel well. There is a plastic platform that has 4 vertical posts protruding from the tray that are used to locate & secure the compressor.

- 1) Identify the mounting location for the compressor & the four (4) vertical posts that will be used to seat the compressor brackets.

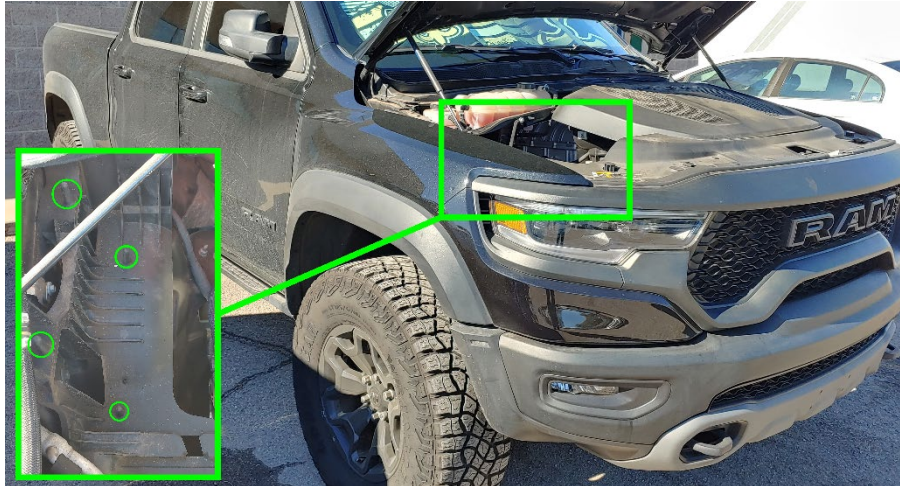

Figure 16- Compressor Mounting Location

- 2) Align the rubber grommets onto the vertical posts **with the compressor head directed towards the cabin.**
- 3) Fully seat the brackets by pushing them down over the posts and forcing the rubber grommets to slide below the retention tabs on the two (2) upper posts.



Figure 17- Compressor Bracket, Installed

- 4) Adjust the position of the below illustrated bracket so that the compressor feet are seated properly with the bracket.
- 5) Fully tighten the hardware so the compressor is fastened securely to the bracket. **Do not overtighten the feet hardware so much that the rubber pads become damaged.**

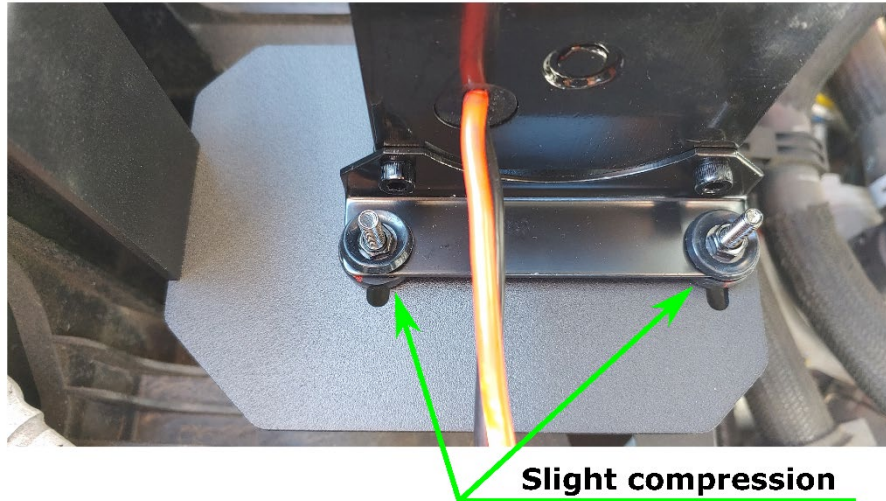

Figure 18- Compressor Rubber Feet

- 6) Loosen (**do not remove**) the nut securing the crossmember support tube as shown below.

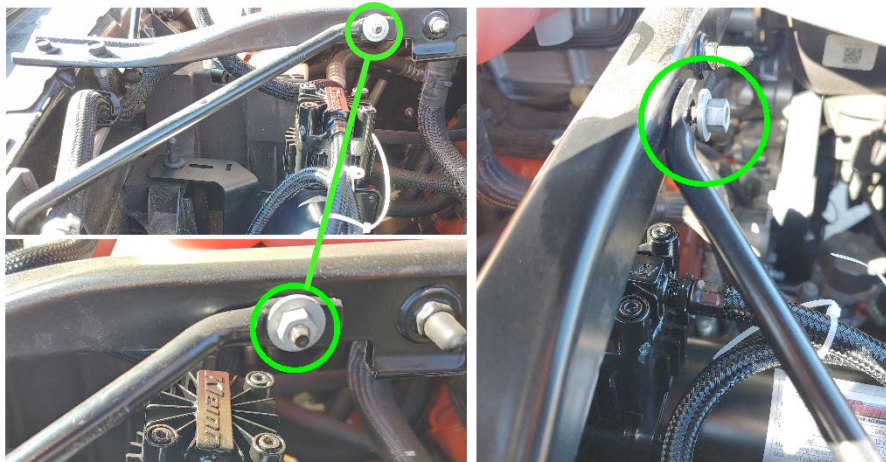
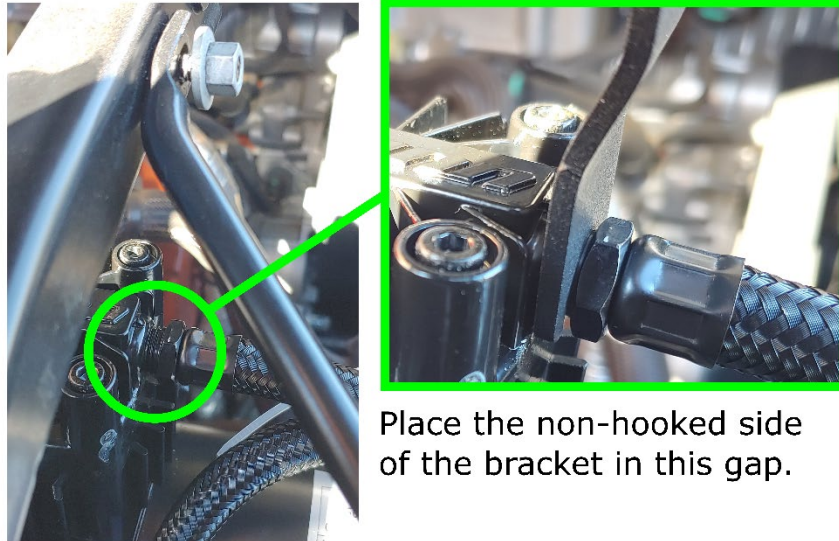

Figure 19- Crossmember Support Tube Location

- 7) Place the Anchor Bracket into the gap between the compressor head & the leader hose.



*Figure 20- Anchor Bracket Placement*

- 8) Pivot the bracket so it hooks behind the loosened nut on the crossmember support tube.
- 9) Fully tighten the nut back to OEM torque specifications.



*Figure 21- Anchor Bracket, Installed*

## 8.2. Tank Installation

The air tank is located above the skid plate, where it mounts onto the same crossmember used to secure the shock reservoirs. The tank mounting system consists of 2 brackets and a custom washer which bolts onto structural members and positions the tank beside the shock reservoirs.

- 1) Remove the OEM skid plate from the underside of the vehicle to get access to the mounting locations for the tank brackets.
- 2) Using hardware H1, place the Tank Support Bracket on top & in front of the primary crossmember shown in the below figures.
  - a. **Insert the carriage bolt (H1) from behind the hard plumbing lines on top of the crossmember.**
  - b. The bracket should be placed over the highlighted hole (Ref. Figure 22 Right) on top of the crossmember and sit next to the mounted shock reservoirs (Ref. Figure 23).

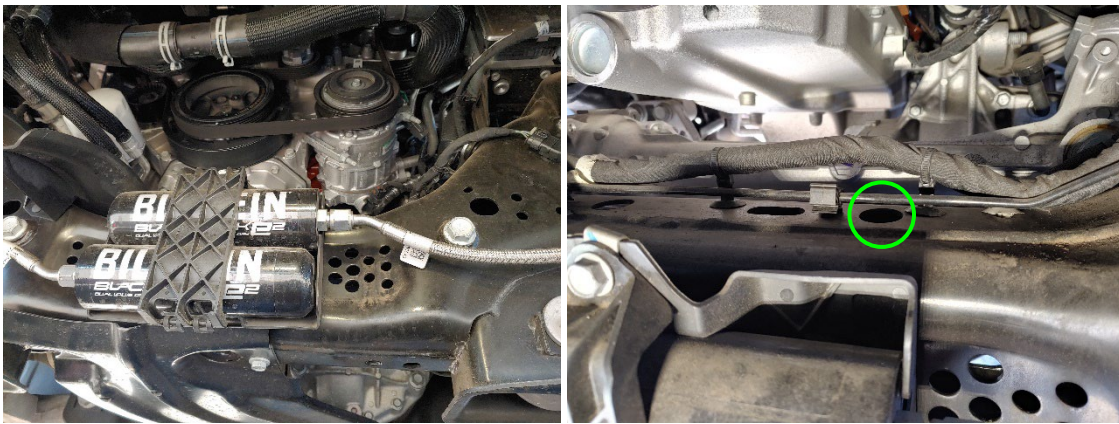

Figure 22- Primary Crossmember (Left) & Top View of Crossmember (Right)

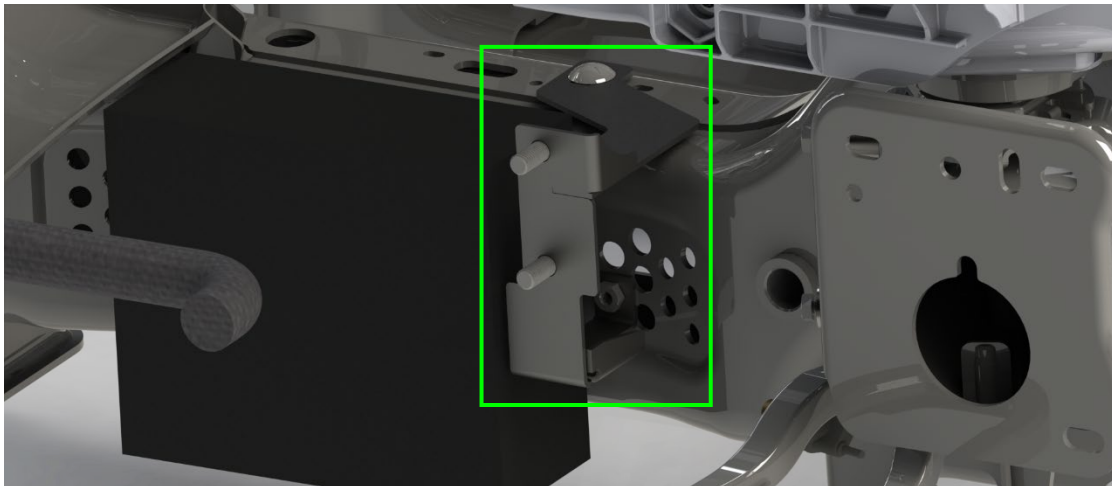
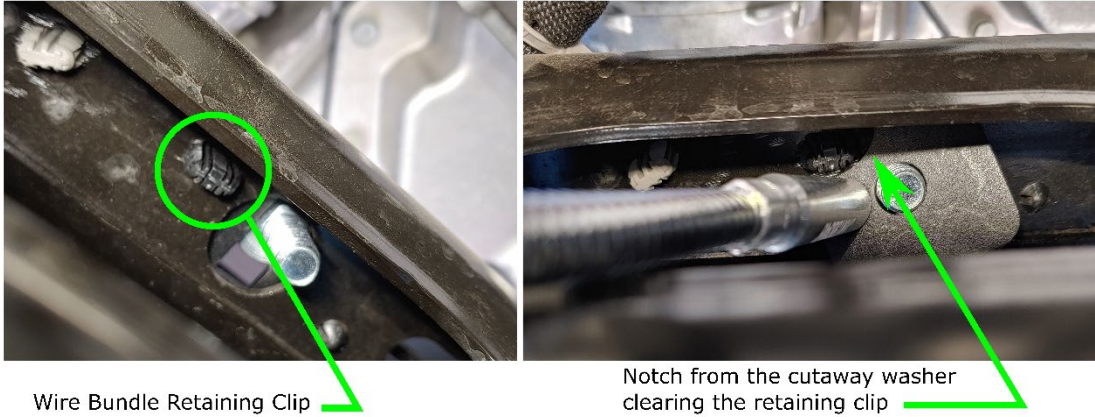

Figure 23- Tank Support Bracket Installed with Carriage Bolt

- 3) From behind & inside the crossmember, use a magnetic pickup tool to place the Cutaway Washer over the carriage bolt and hold it in place.

*NOTE: Ensure the notched portion of the washer is oriented properly to clear the wire bundle retaining clip. See the below figure.*



*Figure 24- Cutaway Washer Placement & Orientation*

- 4) Loosely thread the Nylon Lock Nut (H3) onto the carriage bolt as shown below.





Figure 25- Cutaway Washer Secured via Nylon Lock Nut

- 5) Using hardware H7 & one (1) H10 washer, Align the welded nut (lower part of bracket) with the crossmember hole circled in the below figure & **loosely thread** the hex bolt (H7) & washer (H10) **from the inside of the crossmember**.

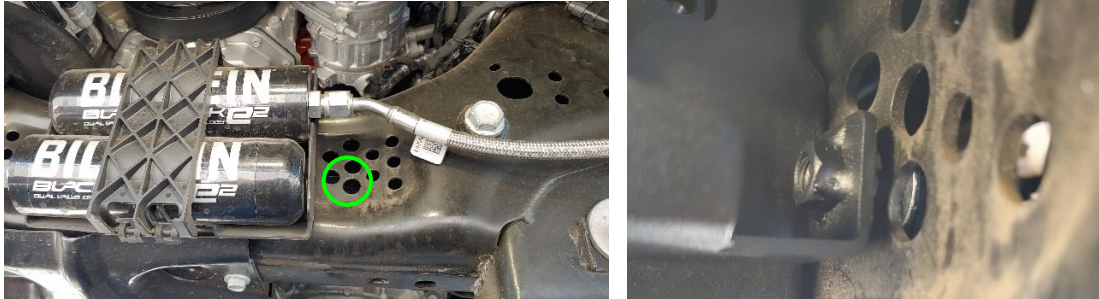

Figure 26- Hardware Installation of Lower Tank Support Bracket

- 6) This bracket will mate up with the following bracket before being fully secured in place.

Follow the next steps to finish installation of the tank mounting brackets.

- 7) Identify the OEM bolts that secure the driver side skid plate mounting bracket as shown in the below figure. It is located behind & above the driver side tow hook.
- 8) Remove the two bolts. **They will not be re-used.**

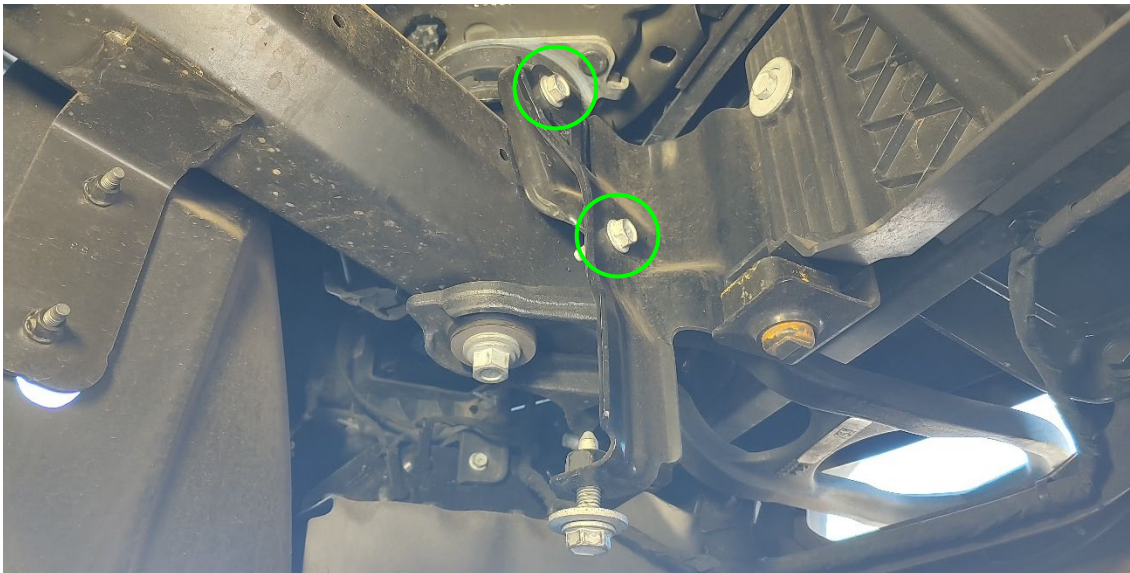

Figure 27- OEM Bolt Removal, Location



Figure 28- OEM Bolts, Removed

- 9) Place the clearance holes of the Primary Tank Bracket over the threaded studs of the Tank Support Bracket
- 10) Temporarily secure the brackets together by using one of the H2 nuts onto the stud.
- 11) Using hardware H16 & H17, align the other side of the primary bracket with the holes from the removed bolts and **fully secure the primary bracket onto the vehicle frame.**

*NOTE: H16 (longer bolt) will be used in the upper bracket hole & H17 (shorter bolt) will be used in the lower hole position (REF. the below figures).*

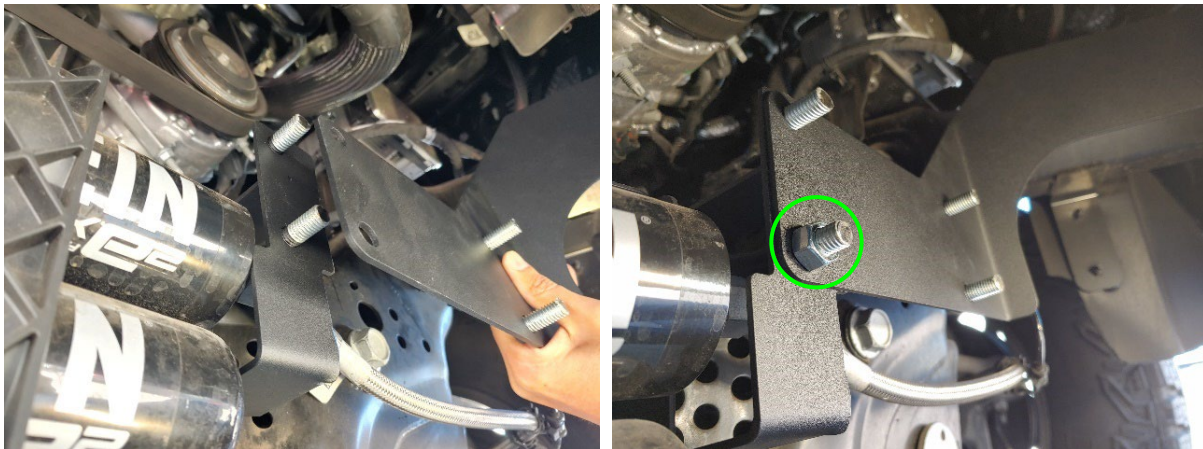

Figure 29- Primary Tank Bracket Installation 1, Steps 9 & 10



Figure 30- Primary Tank Bracket Installation 2, Step 11

12) Fully tighten the bolts on the Tank Support Bracket at this time.

*NOTE: Tighten the nylon lock nut last when performing the above step.*

The tank can now be installed onto the brackets by following the below steps.

13) Remove the nut securing both tank brackets together.

14) Place the tank onto the 4 studs and fasten using QTY: 4 of each hardware H4, H5 & H2 in that stacking order. See the below figure.

15) Fully tighten all hardware.

*NOTE: The air tank has feet that are offset from the center. The longer protrusion of the tank should be directed towards the passenger side, which allows the drain to be pointed towards the ground.*



Figure 31- Tank, Installed

### 8.3. Air Horn Installation – Large Horn

The large air horn is located on the driver side of the vehicle. In between the front & rear doors. It mounts to existing studs on the body, across from the frame rail. It is mounted to the vehicle using the ore brackets (assembled in Bench Steps) & a horn mounting bracket.

- 1) Identify the mounting location of the Ore Brackets previously assembled in Section 7.5 (Ref. the below figures).
- 2) The mounting points are along the body & are covered by 2 plastic slot covers as shown below.

*NOTE: The slots used for the ore brackets are directly forward of body mounted studs in-between the front & rear door area.*



Figure 32- Mounting Location of Ore Brackets

- 3) Remove the plastic slot covers to expose the slot holes.
- 4) Place the ore bracket onto the body and expand the brackets so the tabs seat into the slot openings and hold the brackets in position.

NOTE: Ensure the ore is oriented towards the floor when installing this bracket (REF. the below figure).



Figure 33- Ore Brackets, Installed

- 5) Spread out the brackets as much as possible and fully tighten **only the bracket hardware** to lock the brackets into position.

Directly behind the mounted ore brackets, are 3 studs protruding from the body in a triangle configuration. This is the mounting spot for the Driver Horn Bracket. See the below figure.

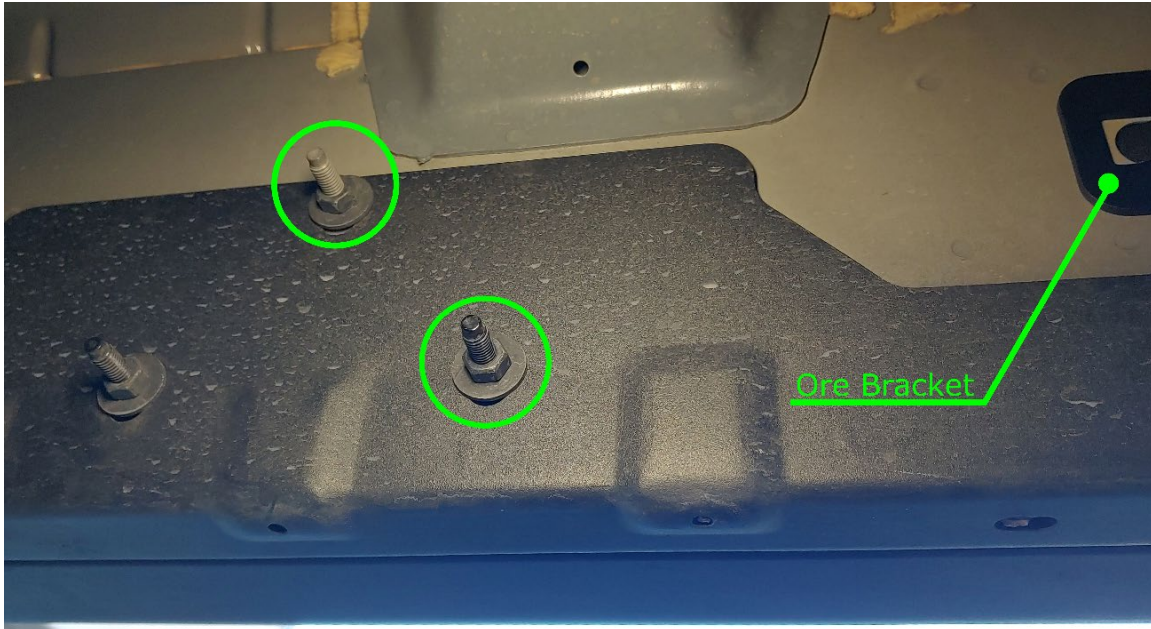

Figure 34- Horn Bracket Mounting Location

- 6) Remove the above highlighted OEM nuts (if present) from the studs and set aside to be reused.
- 7) Place the Driver Horn Bracket onto the studs and reinstall the OEM Nuts or use hardware H24. See the below figure.
- 8) Tighten the hardware to OEM torque spec.



Figure 35- Driver Horn Bracket, Installed

- 9) Using the large horn base (the base **without the solenoid & manifold**), install the largest trumpet onto the base by sliding the trumpet shaft through the Ore and threading it directly into the base.
- 10) Place the base onto the horn bracket and fully tighten the base onto the bracket using QTY:2 of each H20, H21, & H19 (in that stacking order).
- 11) Reposition the Ore as needed to achieve good horn/trumpet alignment & fully tighten the ore hardware.

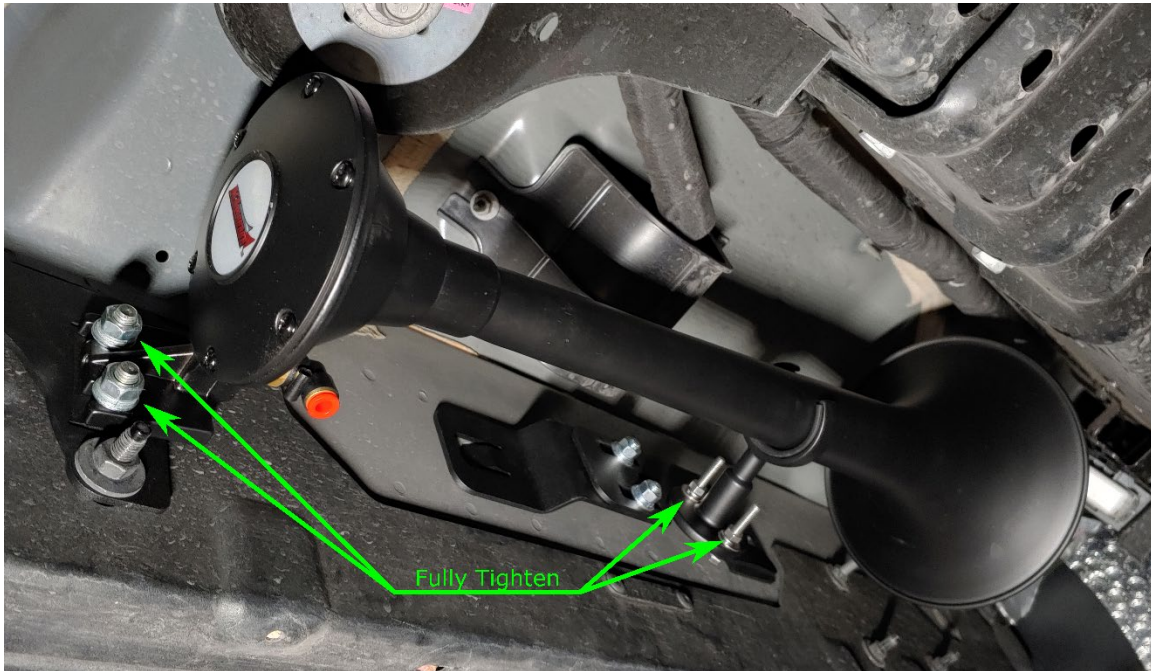

*Figure 36- Driver Side Horn, Installed*

## 8.4. Air Horn Installation – Small Horn

The small air horn is mounted on the passenger side body strut cage, which is located on the outside frame rail, directly in line with the back of the passenger rear door.

- 1) Locate the frame structure that is used to mount the Passenger Horn Bracket, SM (Ref. Section 5.4). The below figure shows the location and mounting spot on the vehicle frame rail.



Figure 37- Small Horn Bracket, Location & Mounting Spot

- 2) Place hardware H12 & H14 on the inside of the body mount (left image of the below figure)
- 3) Install the horn bracket and secure it in place with H15 & H13 (right image of the below figure).  
**Fully tighten the 1/2" hardware only.**

**NOTE:** Align the edge of the bracket in-line with the edge of the frame to allow for the bracket to be oriented properly. Reference the below figure.

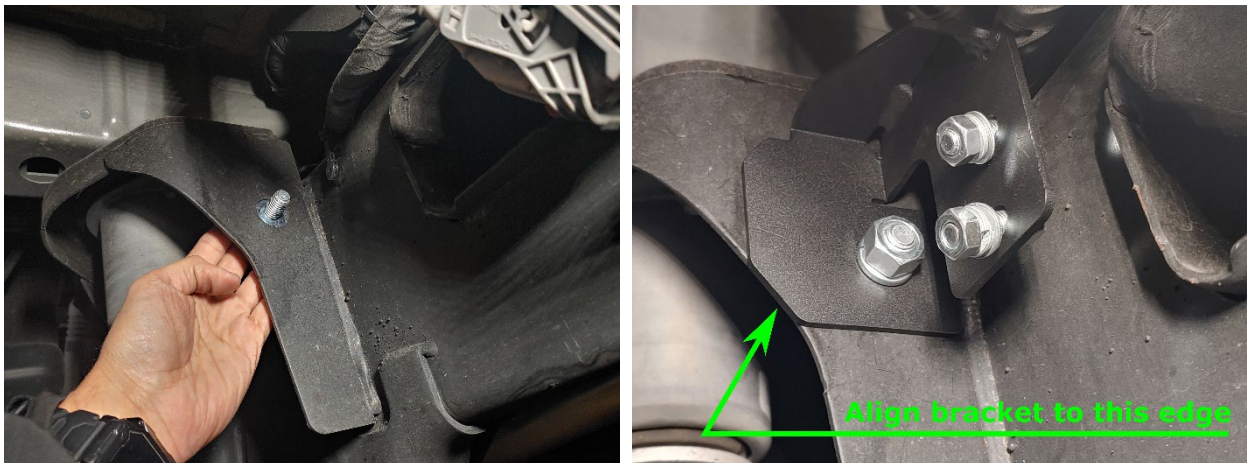
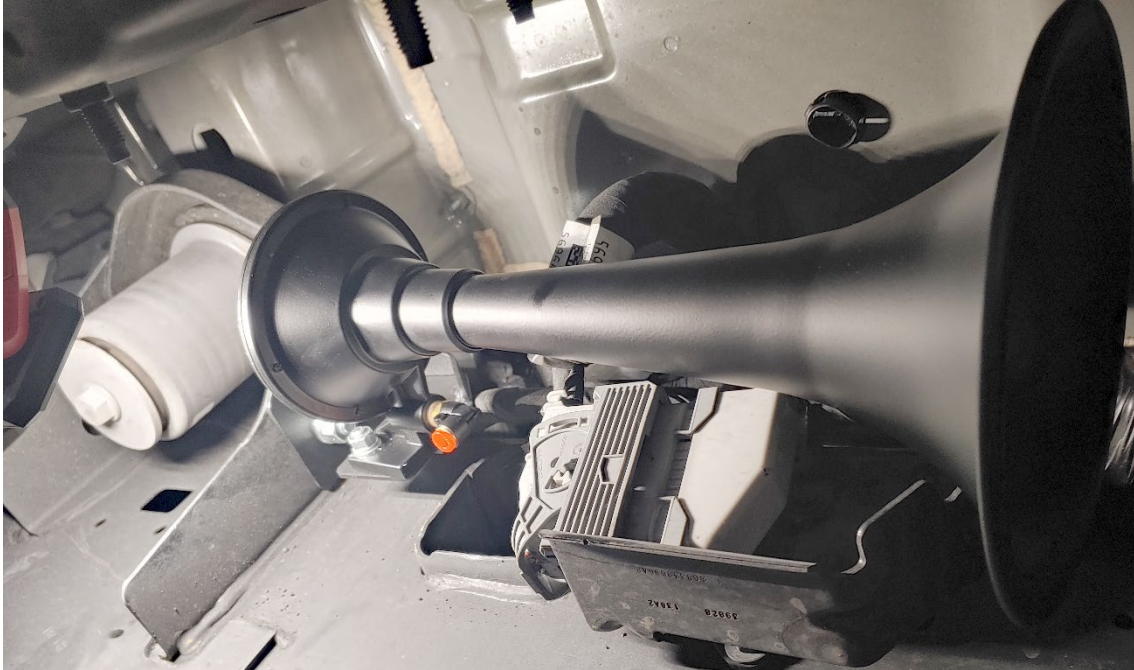

Figure 38- Small Horn Bracket, Installed

- 4) Install the small horn onto the bracket using the loose hardware previously installed on the bracket.
- 5) Position the horn so that it does not hit the metal connector shield and fully tighten the hardware.



*Figure 39- Small Air Horn, Installed*

### **8.5. Air Horn Installation – Medium Horn**

The medium horn is located on the passenger side of the vehicle. In between the front & rear doors. It mounts to existing studs on the body, across from the frame rail. It is mounted to the vehicle using the remaining horn mounting bracket.

It mounts in the same manner as the horn mounting on the driver side.



*Figure 40- Medium Horn Bracket, Location & Mounting Spot*



- 1) Remove the OEM flanged nuts highlighted in the above figure.
- 2) Place the Passenger Horn Bracket, Med on the studs.
- 3) Reinstall the OEM flange (or H24) nuts and fully tighten to OEM torque spec.

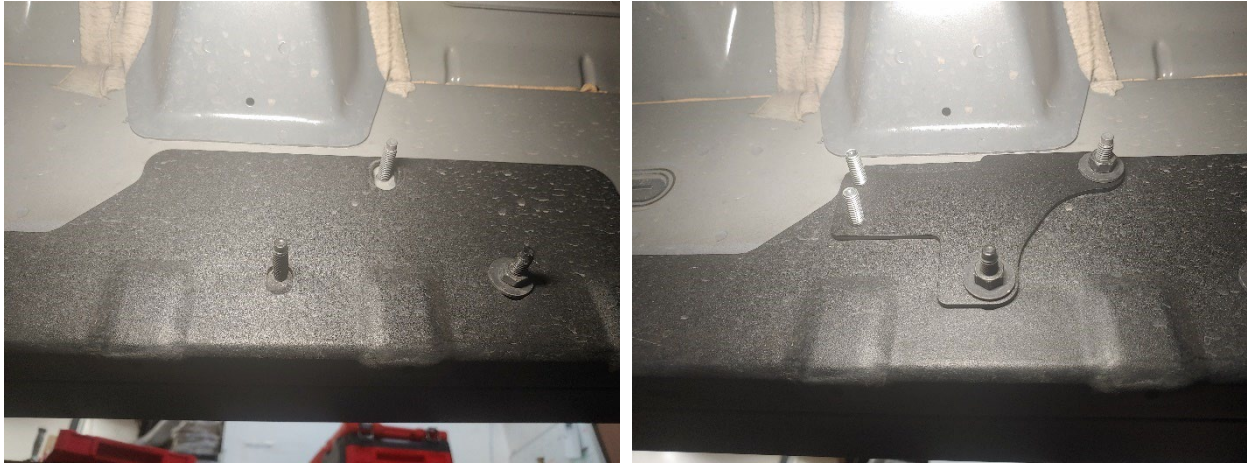

Figure 41- Medium Length Horn Bracket, Installed

- 4) Use Qty: 2 of each hardware H20, H21 & H19 (in that stacking order) and install the medium horn base (base with the solenoid & fittings) onto the bracket.
- 5) Fully tighten the hardware.

**NOTE:** The medium length trumpet should not be installed until the electrical connector is attached and the plumbing from this base is fully routed.

### 8.6. System Plumbing

Using all the included air tubing, route and plumb the tubing between the following:

- 1) The compressor to the air tank.
- 2) The air tank to the medium horn solenoid (1/2" tubing).
- 3) The horn solenoid to the small and large air horns.
- 4) The air tank to the 1302 Relocation Kit.



Figure 42- Final Plumbing of Air System

## 9. On-Vehicle Electrical Installation

It is recommended to disconnect the vehicle battery prior to performing any electrical work.

*NOTE: Review this section in its entirety before performing the following steps.*

### 9.1. Solenoid Connector – Reconfigure & Wiring

To allow for proper fitment, the solenoid connector housing needs to be reconfigured 180°. **It must be disassembled and reassembled at the proper orientation.**



Original Configuration

Final Configuration

*Figure 43- Solenoid Connector, Required Orientation*

- 1) If not already detached, remove the electrical connector from the solenoid.
- 2) Remove the rubber boot to expose the separation slot.
- 3) Use a small pry tool to separate the connector from the housing.

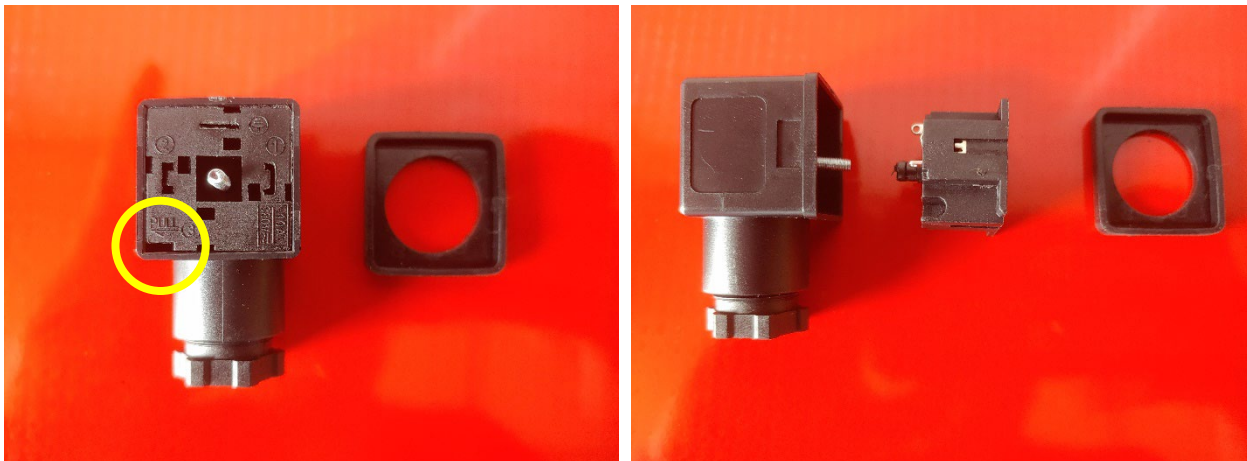

*Figure 44- Connector / Housing Separation*

- 4) Flip the housing over 180°.
- 5) Hookup the Black & Violet wires to the highlighted terminals. Either wire can connect to either terminal.

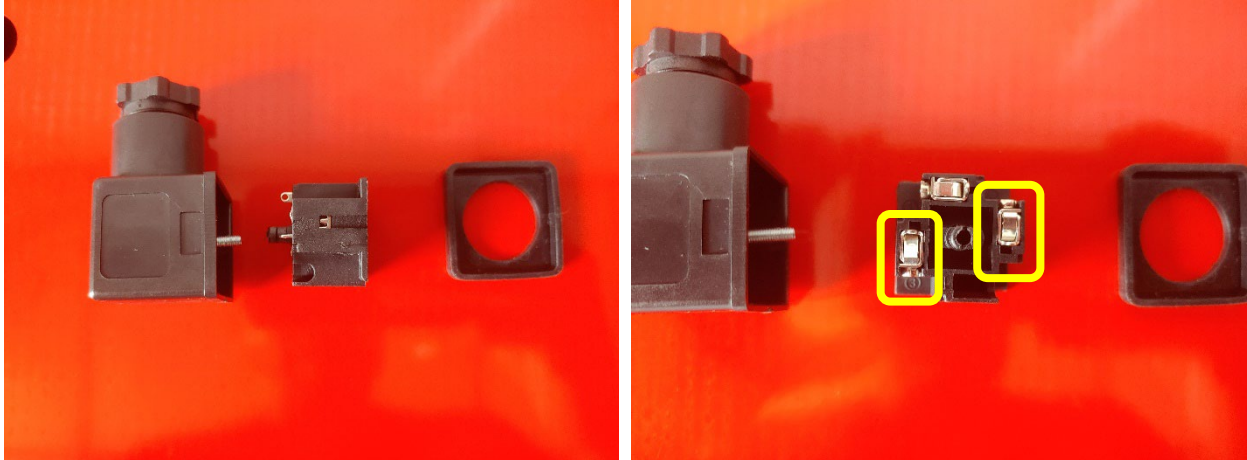

Figure 45- Connector Assembly & Wiring Hookups

- 6) Reassemble the connector.
- 7) Install the connector back onto the solenoid.

*NOTE: It is recommended to use the included loom for all wiring applications.*

- 8) Install the connector onto the solenoid as shown below.



Figure 46- Connector Installation

- 9) The medium length horn trumpet can now be installed onto the base.

### 9.2. Attach Relay & Fuse to Vehicle

Locate a suitable location under the hood and install the fuse housing & relay.

- For the Fuse: Select an area close to the POS (+) battery terminal
- The fuse housing can be attached to the vehicle body panel using the supplied screws
- The relay can be attached to the vehicle body using the supplied self-tapping screws

### 9.3. Install Horn Button

Locate a desirable & accessible location to install the horn button. There should be a minimum of 1" clearance behind pushbutton to allow for the switch to be mounted and wired easily.

Factory upfitter switches may be used at the installers/customers discretion. Consult the owners manual or OEM documentation if using this option.

### 9.4. Route Wiring & Make Connections

Route wiring as desired and make the appropriate connections per the below figure. Use the included wiring loom and crimp connectors as desired.

## 10. Testing the Air System

It is recommended to check your wiring for shorts & continuity & double checking your connections prior to reconnecting the battery.

It is recommended to check the drain valve on the tank and ensure it is fully closed.

### 10.1. Air Compressor Test

1. Start the vehicle & allow the air compressor to run and fill up the tank.

*NOTE: The compressor should turn off after tank reaches  $\approx$  150 PSI. This should take between 2-5 minutes. If the compressor runs excessively, a leak may be present in the system.*

2. Allow the tank to drain via, the horns (if installed), the Inflator kit, or the tanks drain valve.
3. Wait for the compressor to start up again to replenish the air supply.
4. Wait for the compressor to turn off when tank is fully pressurized.

### 10.2. Air Horn Test

Ensure all persons nearby have adequate hearing protection & provide courtesy warning to neighbors before testing the horn system.

**!!WARNING!! NEVER operate the air horns with ears in close proximity to the trumpets or in an enclosed space without SUBSTANTIAL HEARING PROTECTION for all persons closer than 50 feet from the vehicle.!!**

1. Activate the air horns by pressing the horn button briefly. Horns should sound as expected and be loud.

The horn sound & loudness will diminish as the air tank loses pressure. Repeat, if desired, until the compressor turns on and begins refilling the air tank.

### 10.3. Quick Connect Coupler Test

The quick connect coupler can be used to run the included INF-1 tire inflator kit or certain air tools.

1. If needed, allow the air compressor to refill the air tank.
2. Attach the INF-1 inflator kit and inflate tires
3. Optionally, an air blow gun/nozzle or an air nailer can be used to test the quick connect coupling.

## 11. Maintenance

**!!WARNING!!** Operating the air compressor above its maximum pressure rating may damage the internal components and/or cause unsafe system conditions. It is recommended not to exceed 150 PSI pressure in the system.!!

This air compressor is equipped with automatic thermal overload protection. If thermal overload is triggered, the safety circuit will reset after 30 minutes.

This air compressor is oil-less, Never lubricate or add liquids to this compressor.

### **Monthly or every 10 Hours of Compressor Use:**

- Drain the moisture from the air tank via the tanks drain valve.

### **Yearly or 12,000 Miles**

- Replace the compressors air filter element. – Replacement frequency depends on operating & environmental conditions.
- Remove road grime or mud from components & brackets.
- Inspect all mounting fasteners to ensure they remain secure. Tighten as needed.
- Inspect electrical connections & loom for damage. Repair/Replace as needed.

## 12. Warranty Information

Thank you for purchasing this Air System. If you experience any unexpected problems during installation, or part failure at any time, please contact KLEINN Support.

**KLEINN MANUFACTURER LIMITED DEFECT WARRANTY:**

Kleinn Automotive Accessories warrants this product to the end-user, when properly installed and under normal conditions of use, to be free from defects in workmanship and materials for a period of one year from the provided date of purchase to the original purchaser of the product. This warranty does not cover abuse, operation in a manner inconsistent with the product's design, or damage resulting from exposure to the elements. If the defect is considered "under warranty", Kleinn will, at its option, repair or replace the product free of charge to the original purchaser. Kleinn is not liable for any installation charges, loss or damage of any kind incurred in the replacement or repair of any warranted product.

© Kleinn Automotive Accessories, All rights reserved.

PO Box 91278 Tucson, AZ 85752

Phone: [\(520\) 579-1531](tel:5205791531)

Web: [www.Kleinn.com](http://www.Kleinn.com)



# Install Guide

## Record of Revisions

# TRX21-734

| <b>Revision</b> | <b>Description</b>      | <b>Date</b> | <b>Approval</b> |
|-----------------|-------------------------|-------------|-----------------|
| Beta            | Beta Launch Development | 01/22/2024  | AG              |
| A               | Initial Revision        | 5/22/2024   | AG              |
| B               | Updated Section 1.2     | 9/18/2024   | AG              |